



LMV36



AGM60

LMV36.520A1

Basic unit with integrated fuel-air ratio control for forced draft burners

AGM60.4A9

Switch unit for switching the valve control or feedback signals of both fuels

Basic Documentation

The LMV36 / AGM60 and this Basic Documentation are intended for OEMs which integrate the units in their products!

Software version
V03.70

CC1P7544en
17.12.2018

Supplementary documentation

User Documentation Modbus AZL2	A7541
Environmental Product Declaration LMV2 / LMV3	E7541
Installation and Operating Instructions PC Software ACS410	J7352
Data Sheet LMV36	N7544
Product Range Overview LMV2 / LMV3	Q7541

Contents

1	Safety notes	10
1.1	Warning notes	10
1.2	Mounting notes	12
1.2.1	LMV36	12
1.2.2	AGM60	13
1.3	Installation notes.....	14
1.3.1	Use of the AGM60	15
1.4	Electrical connections of LMV36 and AGM60	15
1.4.1	LMV36	15
1.4.2	AGM60	16
1.5	Connection BC interface via integrated RJ11 jack (X56)	17
1.6	Electrical connection of flame detectors	18
1.7	Commissioning notes	19
1.8	Notes on settings and parameter settings	21
1.9	Standards and certificates	22
1.10	Service notes	23
1.11	Life cycle.....	23
1.12	Disposal notes	23
2	Makeup of structure / function description	24
2.1	LMV36	24
2.2	For North American	24
2.3	General information	25
2.4	AGM60	26
2.4.1	Electrical connections of fuel actuators	26
2.4.2	Continuous operation	27
2.4.3	Fuel changeover.....	27
2.4.4	Extra fuel selector.....	27
3	Type summary	28
3.1	LMV36	28
3.2	AGM60	28
3.3	Fuel selector	28
4	Technical data	29
4.1	LMV36 basic unit.....	29
4.1.1	Terminal loading <i>Inputs</i>	29
4.1.2	Terminal loading <i>Outputs</i>	30
4.1.3	Analog output / load output X74 pin 3	31
4.1.4	Cable lengths.....	31
4.1.5	Cross-sectional areas.....	31
4.1.6	Connections of actuators	31
4.2	Signal cable AGV50 from AZL2 → BC interface	32
4.3	Environmental conditions	32
4.4	Flame detectors.....	33
4.4.1	Ionization probe	33
4.4.2	UV flame detectors QRA2 / QRA4 / QRA10.....	35
4.4.3	Photoresistive flame detectors QRB1 / QRB3.....	36

4.4.4	Yellow flame detector QRB4	37
4.5	Switch unit AGM60	38
4.5.1	Terminal output <i>Inputs</i>	39
4.5.2	Terminal output <i>Outputs</i>	39
4.5.3	Cable lengths	40
4.5.4	Cross-sectional areas	40
4.5.5	Electrical connections of actuators	40
4.5.6	Environmental conditions	40
5	Dimensions	41
5.1	LMV36.....	41
5.2	AGM60	42
6	Display and diagnostics	42
7	Basic unit LMV36	43
7.1	Description of inputs and outputs.....	43
7.2	Flame detectors	44
7.2.1	Loss of flame.....	45
7.2.2	Extraneous light	46
7.2.3	No flame at the end of safety time	46
7.2.4	Flame intensity.....	46
7.2.5	Supervision of flame detector	46
7.2.6	Flame detection sensitivity.....	47
7.3	Digital inputs	48
7.3.1	Safety loop X3-04 (optional pressure switch-max), pin 1 and 2.....	48
7.3.2	Burner flange X3-03, pin 1 and 2	49
7.3.3	Input for external load controller (ON / OFF) X5-03, pin 1	49
7.3.4	Air pressure switch X3-02	50
7.3.5	Gas pressure switch for gas valve proving X9-04.....	51
7.3.6	Gas pressure switch-min, start release gas X5-01	52
7.3.7	Oil pressure switch-min X9-04 (X5-01 on AGM60).....	54
7.3.8	Setting the time for checking the pressure switch.....	55
7.3.9	Gas / oil pressure switch-max / or POC contact, start release oil / additional speed-dependent air pressure switch X5-02	56
7.3.10	Fuel selection.....	60
7.3.11	Reset X8-04, pin 1	60
7.4	Digital outputs	61
7.4.1	Output alarm type No-SI X3-05 pin 2	61
7.4.2	Fan motor contactor type SI X3-05, pin 1	61
7.4.3	Fan continuous purging X3-05, pin 3	61
7.4.4	Output ignition type SI (IGNITION) X4-02.....	62
7.4.5	Outputs fuel valves type SI V1 / V2 / V3 / PV X8-02, X7-01, X7-02.....	63
7.4.6	Output safety valve type SI X6-03 / magnetic clutch.....	65
7.4.7	Output for indication of operation X8-04 pin 2	65
7.5	Program sequence.....	66
7.5.1	Time parameters.....	66
7.5.2	Valve proving	68
7.5.3	Valve proving with separate pressure switch X9-04	69
7.5.4	Valve proving via gas pressure switch-min X5-01	70
7.5.4.1.	Lockout phase (phase 00)	71

7.5.4.2.	Safety phase (phase 02)	71
7.5.5	Special functions during the program sequence	72
7.5.5.1.	Reset / manual lockout	72
7.5.5.2.	Alarm upon prevention of startup	73
7.5.5.3.	Possible preventions of startup	73
7.5.5.4.	Repetition counter	74
7.5.5.5.	Start without prepurging (as per EN 676)	76
7.5.5.6.	Gas shortage program	77
7.5.5.7.	Program stop function	78
7.5.5.8.	Forced intermittent operation (<24 hours)	78
7.5.5.9.	Low-fire shutdown	79
7.5.5.10.	Continuous fan	79
7.5.5.11.	Test function for burner approval – loss-of-flame test (TÜV test)	80
7.5.5.12.	Postpurging in the lockout position	81
7.6	Fuel trains (application examples)	82
7.7	Sequence diagrams	90
7.7.1	Gas direct ignition «G», «G mod», «G mod pneu»	91
7.7.2	Gas pilot ignition 1 «Gp1», «Gp1 mod», «Gp1 mod pneu»	92
7.7.3	Gas pilot ignition 2 «Gp2», «Gp2 mod», «Gp2 mod pneu»	93
7.7.4	Light oil direct ignition «Lo», «Lo mod», «Lo 2-stage», «Lo 3-stage»	94
7.7.5	Light oil pilot ignition «LoGp» «LoGp mod» «LoGp 2 stage»	95
7.7.6	Legend to the sequence diagrams	96
8	AGM60	99
8.1	LMV36 with AGM60 and one fuel actuator	99
8.2	LMV36 with AGM60 and two fuel actuators	99
8.3	Connecting cable between AGM60 and LMV36 (AGV61.100 cable)	100
9	Selection of operating mode	101
9.1	Deleting curves	104
10	Connection to load controllers	105
10.1	Load controller ON contact X5-03 pin 1	105
10.2	Load controller via building automation system X92	105
10.3	Manual output	107
10.4	Output with curve settings	107
10.5	External load controller via analog input X64 pin 1 / X64 pin 2	108
10.5.1	Thresholds for modulating operation	108
10.5.2	Switching thresholds for multistage operation	109
10.6	Prioritization of load controller sources	110
10.6.1	Emergency operation with several load controllers sources	111
11	Electronic fuel-air ratio control	112
11.1	General	112
11.2	Behavior outside the operating positions	112
11.2.1	Traveling speed	112
11.2.2	Home position	112
11.2.3	Prepurging	113
11.2.4	Ignition	113
11.2.5	Postpurging	113
11.3	Modulating operation	114

11.3.1	Definition of curves	115
11.3.2	Traveling speed/maximum curve slope	116
11.3.3	Entering the running position	117
11.3.4	Operating position.....	117
11.3.5	Limitation of modulation range.....	118
11.3.6	Setting the minimum and maximum output.....	119
11.4	Multistage operation.....	120
11.4.1	Definition of curves	120
11.4.2	Traveling speed	120
11.4.3	Adjustment of output.....	121
11.4.4	Entering the operating position	121
11.4.5	Operating position.....	121
11.4.6	Limitation of modulation range.....	122
11.5	End of operating position	122
11.6	Notes on settings and parameter settings	123
12	Actuators X53 / X54	124
12.1	Function principle.....	124
12.2	Definition of angles	124
12.3	Referencing.....	125
12.3.1	Reference run	127
12.4	Direction of rotation.....	129
12.5	Monitoring the actuator positions	130
12.6	Changing the error detection band for monitoring the actuator positions	132
12.7	Forced travel	132
12.8	Detection of line interruptions	132
12.9	Protection against mixup of actuator.....	133
12.9.1	Proposal for implementation	133
13	Fan control	134
13.1	Function principle.....	134
13.2	Activation of VSD/PWM fan	134
13.3	VSD control X74 pin 3.....	135
13.4	PWM fan control X64 pin 3	136
13.5	Safe separation of mains voltage and protective extra low-voltage.....	136
13.6	Ramp time.....	137
13.7	Acquisition of speed.....	138
13.7.1	Acquisition of speed with proximity switch	138
13.7.2	Acquisition of speed with Hall generator.....	139
13.7.3	Forced travel fan	140
13.8	Speed control.....	140
13.9	Speed supervision	141
13.9.1	Extended speed supervision.....	142
13.10	Setting the parameters of the VSD	143
13.11	Standardization of speed	144
13.12	Control of fan motor with pneumatic fuel-air ratio control	147
13.13	EMC of LMV36 and VSD	148
13.14	Special conditions for PWM fan in electronic ratio control system.....	148
13.14.1	Characteristics PWM fan	149

13.14.2	Acquisition of speed PWM fan.....	150
13.15	Trim function.....	151
13.15.1	Settings and mode of operation.....	152
13.15.2	Optional internal checks.....	153
13.15.3	External tests (optional).....	155
13.16	Description of connection terminals.....	157
13.16.1	VSD.....	157
13.16.2	PWM fan.....	157
14	Load output X74 pin 3.....	158
14.1	Safe separation of mains voltage and extra low-voltage.....	158
14.2	Modulating operation.....	159
14.3	2-stage operation.....	159
14.4	3-stage operation.....	159
15	Fuel meter input X75 pin 1 / X75 pin 2.....	160
15.1	Configuration of fuel meter.....	160
15.1.1	Types of fuel meters.....	160
15.1.2	Configuration of pulses per volume unit.....	160
15.1.3	Reading and resetting the meter readings.....	160
15.2	Fuel throughput.....	161
15.2.1	Configuration.....	161
15.2.2	Reading out the fuel throughput.....	161
16	Connection and internal diagram.....	162
17	Special feature: Burner identification.....	164
18	Connection to superposed systems.....	164
18.1	General information and building automation functions.....	164
18.2	Modbus.....	166
19	PC software ACS410.....	167
20	Error history.....	168
20.1	Error classes.....	168
20.2	Makeup of error history.....	169
21	Lifecycle function.....	170
22	Safety notes on use of the AZL2.....	170
23	Operating via AZL2.....	171
23.1	Description of unit/display and buttons.....	171
23.2	Meaning of symbols on the display.....	172
23.3	Brightness of display.....	172
23.4	Special functions.....	173
23.4.1	Manual lockout.....	173
23.4.2	Manual control (manual request for output).....	174
23.5	Timeout for menu operation.....	175
23.6	Backup / restore.....	175
23.6.1	Backup.....	176
23.6.2	Restore.....	178
24	Operation of LMV36 via the AZL2.....	180

24.1	Normal display	180
24.1.1	Display in standby mode	180
24.1.2	Display during startup / shutdown	180
24.1.2.1	Display of program phases	180
24.1.2.2	Display of program phase with remaining running time until end of the phase is reached	180
24.1.2.3	List of phase displays	181
24.1.3	Display of operating position	182
24.1.4	Fault status messages, display of errors and info	183
24.1.4.1	Display of errors (faults) with lockout	183
24.1.4.2	Reset	183
24.1.4.3	Activating info / service mode from lockout	183
24.1.4.4	Error with safety shutdown	184
24.1.4.5	General information	184
24.1.4.6	Prevention of startup	184
24.1.4.7	Safety loop	184
25	Menu-driven operation	185
25.1	Assignment of levels	185
26	Info level	186
26.1	Display of info level	186
26.2	Display of info values (examples)	187
26.2.1	Identification date	187
26.2.2	Identification number	187
26.2.3	Burner identification	188
26.2.4	Number of startups resettable	189
26.2.5	Total number of startups	190
26.2.6	End of info level	190
27	Service level	191
27.1	Display of service level	191
27.2	Display of service values (example)	192
27.2.1	Number of faults	192
27.2.2	Error history	192
27.2.3	Intensity of flame	192
27.2.4	End of service level	193
28	Parameter level	194
28.1	Entry of password	195
28.2	Entry of burner identification	197
28.3	Change of heating engineer's password	199
28.4	Change of OEM's password	200
28.5	Use of parameter level	201
28.6	Structure of parameter levels	202
28.7	Parameters without index, with direct display	203
28.7.1	Using the example of parameter 208: Program stop	203
28.8	Parameters without index, with no direct display (with parameters having a value range >5 digits)	205
28.8.1	Using the example of parameter 162: Operating hours resettable	205
28.9	Parameter with index, with direct display	207

28.9.1	Using the example of parameter 501: No-flame positions fuel actuator	207
28.10	Parameters with index, with no direct display	209
28.10.1	Using the example of parameter 701: Errors	209
28.11	Fuel-air ratio curves – settings and commissioning	212
28.11.1	Initial commissioning	212
28.11.2	Setting curvepoints P0 and P9 for modulating operation («G mod», «Gp1 mod», «Gp2 mod» and «Lo mod»)	215
28.11.3	Setting curvepoints P0 and P9 for «G mod pneu», «Gp1 mod pneu» and «Gp2 mod pneu»	216
28.11.4	Warm settings for modulating operation («G mod», «Gp1 mod», «Gp2 mod» and «Lo mod»)	217
28.11.5	Warm settings for modulating mode («G mod pneu», «Gp1 mod pneu» and «Gp2 mod pneu»)	222
28.11.6	Cold settings for «G mod», «Gp1 mod», «Gp2 mod» and «Lo mod»	222
28.11.7	Cold settings for «G mod pneu», «Gp1 mod pneu» and «Gp2 mod pneu»	223
28.11.8	Interpolation of curvepoints	224
28.11.9	Interpolating the curvepoints	225
28.11.10	Setting of curvepoints for multistage mode («Lo 2-stage» and «Lo 3-stage»)	228
28.11.11	Warm settings for «Lo 2-stage» and «Lo 3-stage»	229
28.11.12	Cold settings for multistage mode («Lo 2-stage» and «Lo 3-stage»)	233
28.11.13	Intensity of flame during curve settings	234
29	Parameter list for LMV36.520A1	235
30	Error code list (all LMV2 types / LMV3 types)	257
31	Revision history of LMV36	274
31.1	List of figures	280

1 Safety notes

1.1 Warning notes



To avoid injury to persons, damage to property or the environment, the following warning notes must be observed!

LMV36 and AGM60 are safety devices! Do not open, interfere with or modify the units. Siemens does not assume responsibility for damage resulting from unauthorized interference!

Additional safety notes contained in other chapters of this document must be observed as well!

After commissioning and after each service visit, check the flue gas values across the entire load range!

The present Basic Documentation describes a wide choice of applications and functions and shall serve as a guideline. The correct functioning of the units must be checked and proven by function checks on a test rig or on the plant itself!

- All activities (mounting, installation and service work, etc.) must be performed by qualified personnel
- Degree of protection IP40 as per DIN EN 60529 for the LMV36 must be ensured through adequate mounting of the LMV36 and the AGM60 by the burner or boiler manufacturer
- Before making any wiring changes in the connection area, completely isolate the plant from mains supply (all-polar disconnection). Ensure that the plant cannot be inadvertently switched on and that it is indeed dead. If not disconnected, there is a risk of electric shock hazard
- Protection against electric shock hazard on the LMV36, the AGM60 and on all connected electrical components must be ensured through adequate mounting. In terms of design, stability and protection, the cover used must conform to EN 60730
- After each activity (mounting, installation and service work, etc.), check to ensure that wiring is in an orderly state and that the parameters are correctly set
- Fall or shock can adversely affect the safety functions. Such units must not be put into operation even if they do not exhibit any damage
- When programming the air-fuel ratio control curves, the commissioning engineer must constantly watch the quality of the combustion process (e.g. by means of a flue gas analyzer) and, in the event of poor combustion values or dangerous conditions, take appropriate actions, e.g. by shutting down the LMV36 manually
- When starting up a dual-fuel burner, both fuel trains must be put into full operation, thus making certain that fuel changeover by the user cannot lead to critical conditions
- The inputs and outputs of the AGM60 may only be used for the application covered by this document and only in connection with the sensors and actuators specified for the application, the reason being that only these have been checked and released in terms of error effects. If you want to use the sensors and actuators on other applications, please contact Siemens
- The following plug-on terminations carry FELV (functional extra low-voltage) (also refer to chapter *Electrical connection of LMV36 and AGM60*), thus ensuring adequate separation from mains voltage:
 - BC interface (X56) for the connecting cable of AZL2 or PC software ACS410
 - COM (X92) for accessories, such as the OCI410.
 - Plug-on terminations for actuators (X54) or for the AGV61.100 connecting cable when using 2 fuel actuators via AGM60These plug-on terminations may be disconnected or exchanged only when the plant is dead (all-polar disconnection)

- The plugs of the connecting cables for the LMV36 or other accessories, such as the OCI410 interface (plugged into the BC interface), may be removed or exchanged only when the plant is shut down (all-polar disconnection), since the BC interface does not provide safe separation from mains voltage.
- The connection for the SQM3 or SQN1 actuators does not provide safe separation from mains voltage. Prior to connecting or changing one of these actuators, the plant must be shut down (all-polar disconnection)
- When setting up a system with the AGM60, check to ensure that the sensors and actuators are correctly assigned to fuels

To ensure safety and reliability of the LMV36 and the AGM60, the following points must also be observed:

- Condensation and ingress of humidity must be avoided. Should such conditions occur, make sure that the unit is completely dry before switching on again!
- Static charges must be avoided since they can damage the unit's electronic components when touched.
Recommendation: Use ESD equipment
- If the unit fuse was blown due to overload or a short-circuit at the connection terminals, the LMV36 must be replaced since the switching contacts could have been damaged
- If error codes 95...98 appear during operation, this may be an indication of contact problems and the LMV36 should be replaced

1.2 Mounting notes

- Ensure that the relevant national safety regulations and regulations relating to standards are complied with
- In geographical areas where DIN regulations apply, the requirements of VDE must be satisfied, especially DIN / VDE 0100, 0550 and DIN / VDE 0722

1.2.1 LMV36

- The LMV36 must be secured with fixing screws M4 (UNC32) or M5 (UNC24), observing a maximum tightening torque of 1.8 Nm and using all 4 fixing points. Additional mounting surfaces on the housing are provided to improve mechanical stability. These must completely rest on the mounting surface to which the unit is secured. The flatness of that mounting surface must be within a tolerance band of 0.3 mm
- Touch protection of the external fuel selector must be ensured by fitting the selector as a separate component (e.g. in a control panel door or under the burner hood)

Notes on mounting

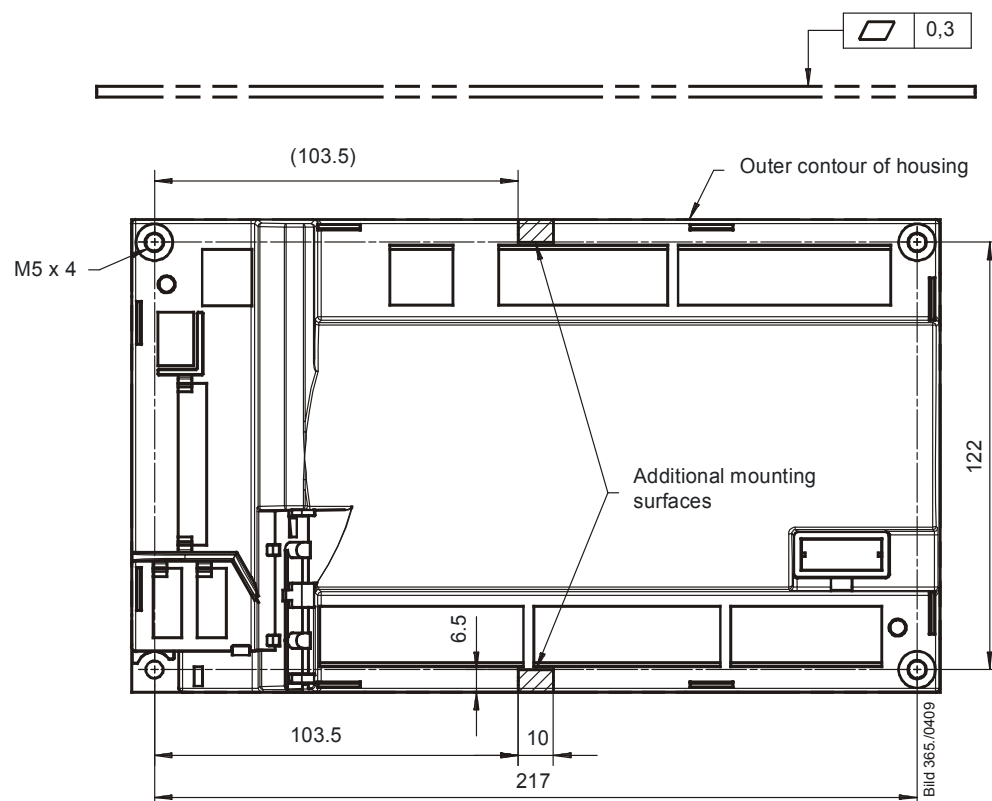

Figure 1: LMV36 note on mounting

1.3 Installation notes

- Always run the high-voltage ignition cables separate from the unit and other cables while observing the greatest possible distances
- Ensure that the electrical wiring inside the boiler is in compliance with national and local safety regulations
- Mains power must always be supplied via *L* and *N*. This means that no potential differential must exist between the neutral conductor *N* and protective conductor *PE*
- Phase and neutral conductor must not be interchanged (dangerous malfunctions, loss of protection against electric shock hazard, etc.)
- Make certain that strain relief of the connected cables is in compliance with the relevant standards (e.g. as per DIN EN 60730 and DIN EN 60335)
- Ensure that spliced wires cannot get into contact with neighboring terminals. Use adequate ferrules
- The burner manufacturer must protect unused terminals of LMV36 and AGM60 by fitting dummy plugs (exception: X64 (reserved) and X74)
- When making the wiring, ensure that the AC 120 V sections is strictly separated from other voltage sections, thus ensuring protection against electric shock hazard (for more detailed information, refer to chapter *Electrical connection of LMV36 and AGM60*)
- The plugs of connecting line for the LMV36, must be connected or disconnected only when the plant is dead (all-polar disconnection), since the BC interface does not ensure safe separation from mains voltage
- AGV50 signal cable from LMV36 and AZL2.
Since the BC interface carries FELV (refer to chapter *Electrical connection of LMV36 and AGM60*), use of the AGV50 signal cable for connection from the LMV36 to the AZL2 is mandatory, or observe the respective specification. The signal cable is specified for use under the burner hood. When using other types of signal cable that do not conform to the specification, protection against electric shock hazard is not necessarily ensured
- Do not lay signal cable AGV50 from the LMV36 to the AZL2 together with other cables
- Service operation with a longer signal cable from the LMV36:
If a longer signal cable is required for service work for example (short-time usage, <24 hours), note that the above application under the burner hood no longer applies and, for this reason, the signal cable can be subjected to increased mechanical stress. In that case, use a reinforced signal cable
- Both the AGV50 signal cable and the AZL2 must be shipped and stored so that no damage due to dust and water can occur when the products are used in the field
- To ensure protection against electric shock hazard, make certain that – prior to switching on power – the AGV50 signal cable is correctly connected to the AZL2
- The AZL2 must be used in a dry and clean environment
- The connection between the actuators and the regulating units for fuel and combustion air or any other regulating units must be form-fitted
- Once the LMV36 has been installed in the equipment, a check must be carried out to ensure compliance with the EMC emission requirements!
- When grounded PELV signals are connected to the SELV terminals of the burner control, they also become PELV voltages (according to EN 60730-1, chapter 11.2.7, EN 298 chapter 9.2.d)
- An isolating transformer grounded on one side must be used if the wiring takes place with a mains circuit without a grounded conductor or the mains supply between the phases (in accordance with EN 298-1, chapter 9.2.d)
- To prevent high-energy couplings due to magnetic induction or capacitive coupling, the cable lengths must be >10 m on the detector cables and communication lines with a shielded cable, grounded on both sides (based on requirements from EN 13611)
- Testing torque of the screws RAST5 connector: 0.5 Nm
- Testing torque of the screws RAST3.5 connector: 0.25 Nm

1.3.1 Use of the AGM60

- To ensure correct fuel changeover, output *safety valve / magnetic clutch* (X6-03 pin 3) must be connected to the respective input of the AGM60 (X32-01 pin 5).

The reason being the following:

Depending on the signal level at this output, the AGM60 sends the point in time for fuel changeover to the LMV36.



Caution!

The AGM60 must always be powered via the LMV36 and never directly by mains voltage.

- The live conductor for fuel changeover (refer to chapter *Fuel changeover*) must always be picked up at terminal X31-01 pin 4 of the AGM60
- Connecting cable between LMV36 and AGM60 (also refer to chapter *Makeup of system*): Use of this connecting cable is mandatory (available as an accessory item, refer to chapter *Type summary*)

1.4 Electrical connections of LMV36 and AGM60

For LMV36 and AGM60, the following low-voltage categories are in use:

- SELV (safety extra low-voltage) and PELV (protective extra low-voltage) ensure protection against electric shock hazard
- FELV (functional extra low-voltage)
Functional extra low-voltage without safe separation provides no protection, so that risk would not be excluded in the event of failure

1.4.1 LMV36

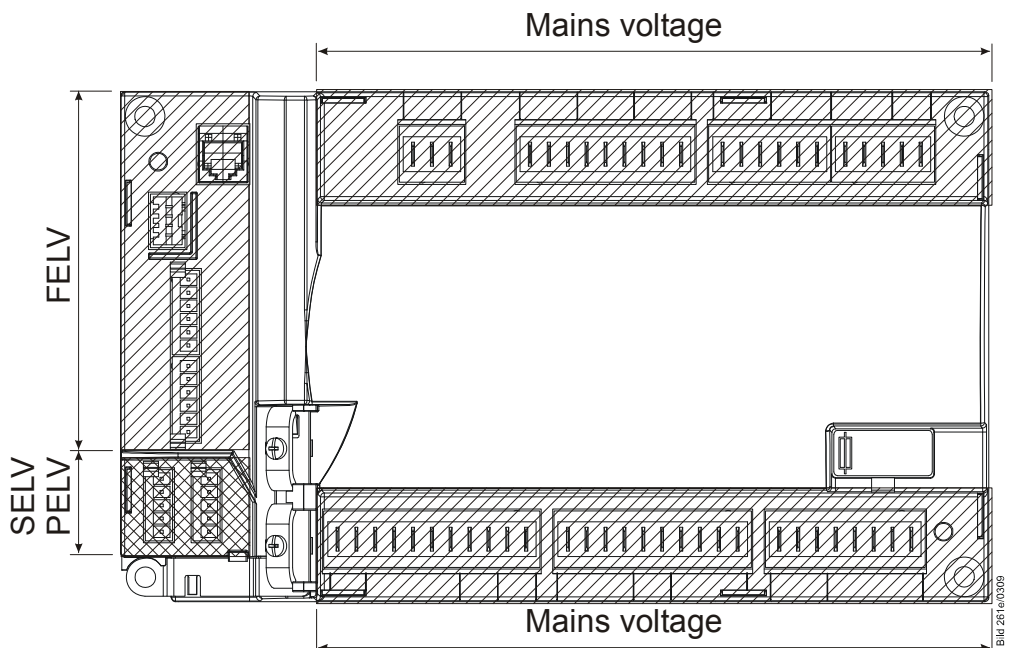

Figure 4: LMV36 electrical connection



Note

The safety class of the connected components determines whether SELV or PELV applies. In the case of PELV, the respective component is earthed and connected to protective earth.

1.4.2 AGM60

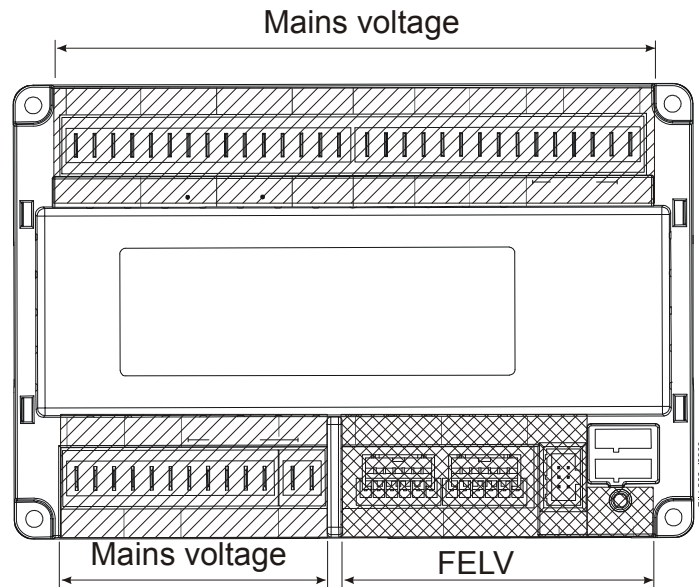

Figure 5: AGM60 electrical connection

When installing the unit, make certain that non-insulated parts in the mounting frame do not get into contact with the connection terminals. Also observe the lateral connecting area:

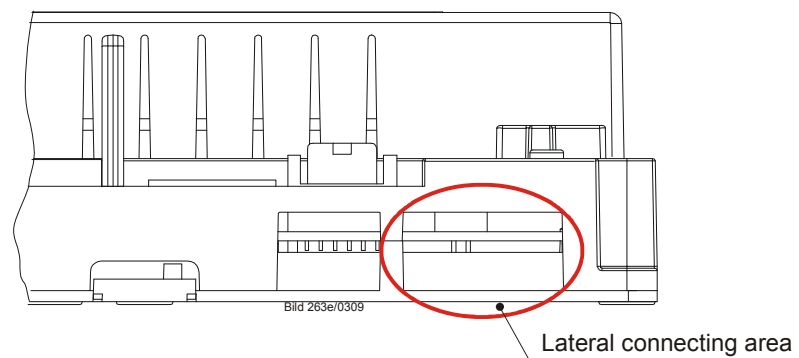

Figure 6: AGM60 lateral connecting area

1.5 Connection BC interface via integrated RJ11 jack (X56)

- If the BC interface (jack RJ11) is not used, protection against electric shock hazard must be provided (jack must be covered up)
- The AZL2 signal cable or other accessories like the OCI410 interface (plugged into the RJ11 jack), may only be plugged in or disconnected when the unit is dead (all-polar disconnection), since the BC interface does not provide safe separation from mains voltage
- The AZL2 is designed for direct connection to the integrated RJ11 jack on the LMV36
- Signal cable from LMV36 to AZL2 must conform to certain specifications. Siemens has specified the signal cable for use under the burner hood. When using other signal cables, it is not guaranteed that the required cable features will be met.
- Do not lay the signal cable from the LMV36 to the AZL2 together with other cables. Use a separate cable
- Service operation with a longer signal cable from LMV36 to AZL2
If a longer signal cable is required for service work, for example (short-time, <24 hours), note that the above usage under the burner hood no longer applies and, for this reason, the signal cable can be subjected to increased mechanical stress. Extra cable sheathing is therefore required
- Both the signal cable and the AZL2 must be shipped and stored so that no damage due to dust and water can occur when used in the plant later on
- To ensure protection against electric shock hazard, make certain that, prior to switching on power, the signal cable is correctly connected to the AZL2
- The AZL2 must be used in a dry and clean environment

Connection interface OCI410 on the BC interface

Connect the OCI410 interface without other extension with the USB interface at your PC, follow the example design below.

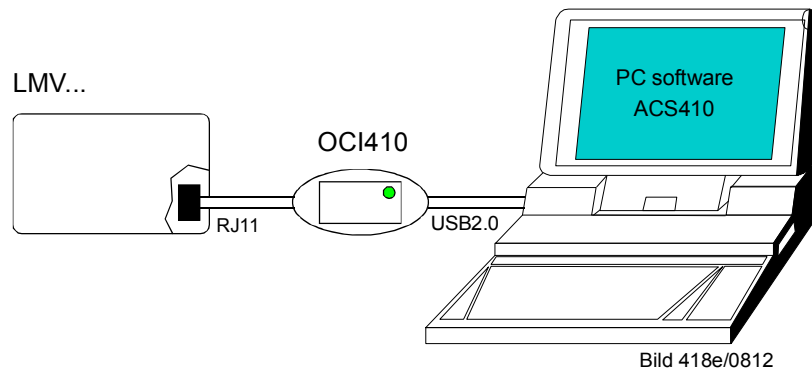

Figure 7: Connection interface OCI410 on the BC interface

1.6 Electrical connection of flame detectors

It is important to achieve practically disturbance- and loss-free signal transmission:

- Never run the detector cables together with other cables
 - Line capacitance reduces the magnitude of the flame signal
 - Use a separate cable
- Observe the permissible detector cable lengths
- The mains-powered ionization probe is not protected against electric shock hazard. It must be protected against accidental contact
- Earth the burner in compliance with the relevant regulations; earthing the boiler alone does not suffice
- Locate the ignition electrode and the ionization probe such that the ignition spark cannot arc over to the ionization probe (risk of electrical overloads)
- Insulation resistance
 - The insulation resistance must be $>50\text{ M}\Omega$ between ionization probe and ground
 - Soiled detector holders reduce the insulation resistance, thus supporting creepage currents

1.7 Commissioning notes

- When commissioning the unit, check **all safety functions**
- There is no absolute protection against incorrect use of the RASTx connectors. For this reason, prior to commissioning the plant, check the correct assignment of all connectors
- Electromagnetic emissions must be checked on an application-specific basis

After the plant has been installed and commissioned, the person responsible for the plant / heating engineer must **document** the parameterized values and settings (e.g. curve characteristics) used for fuel-air ratio control.

These data can be printed out with the help of the ACS410 PC software, for example, or must be written down.

This document must be kept in a safe place and checked by the expert.



Caution!

On the OEM level of the LMV36, parameter settings other than those specified in the application standards can be made. For this reason, check whether the parameter settings made are in compliance with the relevant application standards (e.g. EN 676, EN 267, etc.), or whether the respective plant demands special approval!

Fuel-air ratio control system

The selected setting values of fuel and combustion air must be assigned such that – while giving consideration to the combustion chamber / fuel pressure, temperature and combustion air pressure, as well as wear of actuators and controlling elements, etc. – correct operation with sufficient amounts of excess air is ensured across the burner's full output range for an extensive period of time (until the next regular inspection is due; also refer to chapter *Monitoring the positions*). This must be proven by the burner / boiler manufacturer by measuring the characteristic combustion process values. If the standardization process is repeated, the fuel-air ratio control system must be rechecked.

LMV36

Prior to commissioning the system, the following points must be checked:

- Parameterization of operating mode (e.g. «G mod», «Gp1 mod», «Lo mod», etc.) must accord with the type of burner used (refer to chapter *Selection of operating mode*)
- Correct assignment of the valves to the valve outputs of the LMV36
- Correct setting of the time parameters, especially the safety and prepurge times
- Correct functioning of the flame detector in the event of loss of flame during operation (including the response time), with extraneous light, during the prepurge time and, when there is no establishment of flame, at the end of the safety time
- Activation of the valve proving function and determination of the correct leakage rate, if required by the application (refer to chapter *Valve proving*)

The functions of the following available or required input status signals must be checked:

- Air pressure
- Minimum gas pressure / maximum gas pressure or POC
- Gas pressure valve proving
- Minimum oil pressure and maximum oil pressure
- Safety loop (e.g. safety limiter)

Duties of the expert when making the approval tests

	Action	Check / response
a)	Burner startup with flame detector darkened	Lockout at the end of first safety time
b)	Burner startup with flame detector exposed to extraneous light, e.g. to incandescent light with detectors for visible radiation, quartz-halogen bulb or cigarette lighter flame with detectors for UV radiation	Lockout at prepurge time
c)	Simulation of loss of flame during operation. For that, darken the flame detector in the operating position and maintain that state	Lockout or restart, depending on the LMV36 configuration
d)	Check the plant's response time with loss of flame during operation. For that purpose, manually disconnect the fuel valves from power and check the time from this moment the LMV36 requires to turn off power to the valve	Turning off power to the valves by the LMV36 within the period of time permitted for the respective type of plant
e)	Check the safe operation of the burner while giving consideration to LMV36 tolerances	<p>LMV36 tolerances are the result of a number of factors.</p> <p>Such as:</p> <ul style="list-style-type: none"> • Tolerances of actuators plus mechanical linkage to the controlling elements • Environmental conditions (temperature, air conditions) • Type of fuel (calorific value / pressure) • Type of supply air path and flue ways <p>Example of procedure for checking the burner's response to actuator tolerances:</p> <ul style="list-style-type: none"> • Approach a output point in programming mode (e.g. low-fire or high-fire) • Change the actuator's position against the optimum fuel-air ratio setting as can be expected in the case of tolerances • Check the flue gas values with a flue gas analyzer <p>Recommendation: Make this readjustment against the optimum fuel-air ratio setting for one actuator at a time!</p>

Further checks may be required, depending on the field of use and the relevant standards.

1.8 Notes on settings and parameter settings

- When adjusting the electronic fuel-air ratio control system integrated in the LMV36, allow for sufficient amounts of excess air since – over a period of time – the flue gas settings are affected by a number of factors (e.g. density of air, wear of actuators and controlling elements, etc.). For this reason, the flue gas values initially set must be checked at regular intervals
- To safeguard against inadvertent or unauthorized parameter transfer from the PC software ACS410 to the LMV36, the OEM must assign an individual burner identification (ID) for each burner. Compliance with this regulation is mandatory to ensure that the LMV36 prevents the transfer of parameter sets of some other plant (with inadequate and possibly dangerous parameter values) to the LMV36 via the PC software ACS410. In addition, the fuel-air ratio control parameters must be manually approached and the combustion values checked
- With the LMV36, it is to be noted that the unit's characteristics are determined primarily by the specific parameter settings rather than the type of unit. This means that, among other things, each time a plant is commissioned, the parameter settings must be checked and the LMV36 must not be transferred from one plant to another without adapting the parameter settings to the new plant
- When using the ACS410 PC software, the safety notes given in the relevant Installation and Operating Instructions (J7352) must also be observed
- A password protects the parameter level against unauthorized access. The OEM allocates individual passwords to the setting levels he can access. The default passwords used by Siemens must be changed by the OEM. These passwords are confidential and may only be given to persons authorized to access such setting levels
- The responsibility for setting the parameters lies with the person who – in accordance with his access rights – made changes to the respective setting level

In particular, the OEM (burner and / or boiler manufacturer) assumes responsibility for the correct parameter settings in compliance with the standards covering the specific applications (e.g. EN 676, EN 267, EN 746-2, etc.).

1.9 Standards and certificates



Applied directives:

- Low-voltage directive 2014/35/EC
- Directive for pressure devices 2014/68/EC
- Gas Appliances Regulation (EU) EU/2016/426
- Electromagnetic compatibility EMC (immunity) *) 2014/30/EC

*) The compliance with EMC emission requirements must be checked after the burner management system is installed in equipment

Compliance with the regulations of the applied directives is verified by the adherence to the following standards / regulations:

- Automatic burner control systems for burners and appliances burning gaseous or liquid fuels DIN EN 298
- Safety and control devices for gas burners and gas burning appliances - Valve proving systems for automatic shut-off valves DIN EN 1643
- Gas/air ratio controls for gas burners and gas burning appliances - Part 2: Electronic types DIN EN 12067-2
- Safety and control devices for burners and appliances burning gaseous and/or liquid fuels — General requirements DIN EN 13611
- Safety and control devices for gas burners and gas-burning appliances - Particular requirements Part 1: Automatic and semi-automatic valves ISO 23552-1
- Automatic electrical controls for household and similar use Part 2-5: Particular requirements for automatic electrical burner control systems DIN EN 60730-2-5

The relevant valid edition of the standards can be found in the declaration of conformity!



Note on **DIN EN 60335-2-102**

Household and similar electrical appliances - Safety - Part 2-102:

Particular requirements for gas, oil and solid-fuel burning appliances having electrical connections. The electrical connections of the LMV36 and the AGM60 comply with the requirements of EN 60335-2-102.



EAC Conformity mark (Eurasian Conformity mark)



ISO 9001:2015
ISO 14001:2015
OHSAS 18001:2007



China RoHS
Hazardous substances table:
<http://www.siemens.com/download?A6V10883536>



1.10 Service notes

- **If fuses are blown, the unit must be returned to Siemens** (refer to chapter *Warning notes*)
- Error diagnostics can only be made via the LMV36 (BC interface)



Note!

Only authorized persons may replace the fuse (according to EN 298-1, chapter 9.2.r)

1.11 Life cycle

LMV36	The burner management system has a designed lifetime* of 250,000 burner startup cycles which, under normal operating conditions in heating mode, correspond to approx. 10 years of usage (starting from the production date given on the type field).
AGM60	The AGM60 has a designed lifetime* of 5,000 burner startup cycles which, under normal operating conditions in heating mode, correspond to approx. 10 years of usage (starting from the production date given on the type field).
General	This designed lifetime is based on the endurance tests specified in standard EN 298. A summary of the conditions has been published by the European Control Manufacturers Association (Afecor) (www.afecor.org).

The designed lifetime is based on use of the LMV36 / AGM60 according to the manufacturer's Data sheet and Basic Documentation. When reaching the designed lifetime in terms of the number of burner startup cycles or time of usage, the LMV36 / AGM60 must be replaced by authorized personnel.

* The designed lifetime is not the warranty time specified in the Terms of Delivery

1.12 Disposal notes

The unit contains electrical and electronic components and must not be disposed of together with domestic waste. Local and currently valid legislation must be observe

2 Makeup of structure / function description

2.1 LMV36

The LMV36 is a microprocessor-based burner management system with matching system components for the control and supervision of forced draft burners of medium to high capacity.

For using of dual fuel with 2 fuel actuators, AGM60 is required.

Following are integrated in the LMV36:

- Burner management system complete with valve proving system
- Electronic fuel-air ratio control system for a maximum of 2 SQM3 or SQN1 actuators
- Control of VSD for air fan
- Modbus interface

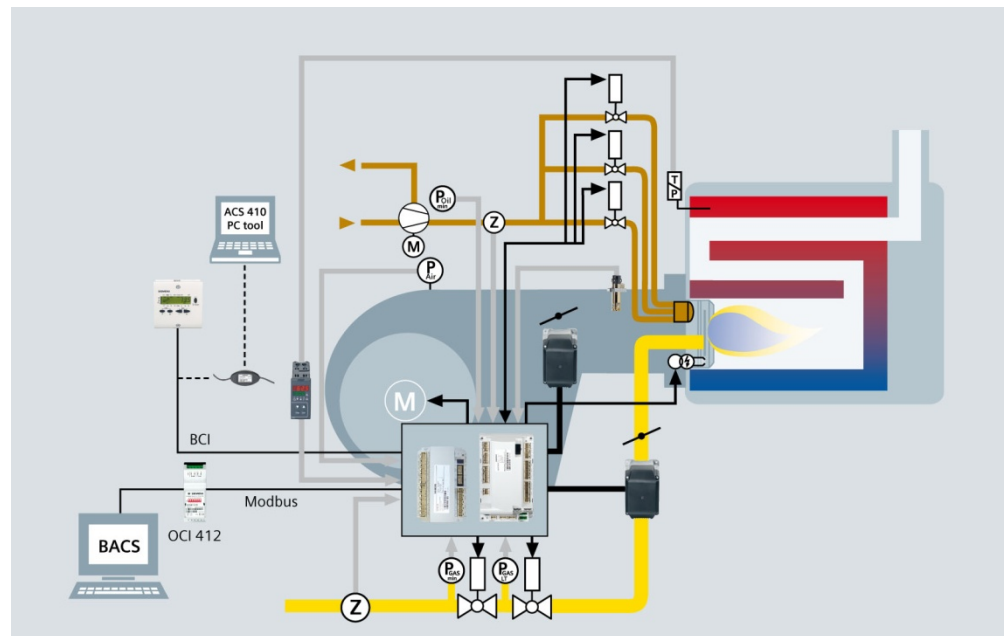

Figure 8: Makeup of structure

Example: Dual fuel burner, gas modulating and oil 3-stage

The system components (AZL2, actuators) are connected directly to the LMV36. All safety-related digital inputs and outputs of the LMV36 are monitored by a contact feedback network.

The diagram shows the maximum functionality of the LMV36 system. The actual functions are to be determined based on the respective execution / configuration.

2.2 For North American

For intermittent operation in connection with the LMV36 / AGM60 the ionization probe or the QRA or QRB optical flame detectors can be used. **Continuous operation is possible only when using an ionization probe and without AGM60.**

2.3 General information

The burner management system is operated and parameterized either via the AZL2 or with the help of the PC software ACS410.

The AZL2 with LCD and menu-driven operation facilitates straightforward use and targeted diagnostics.

When making diagnostics, the display shows the operating states, the type of error and the point in time the error occurred.

Passwords protect the different parameter levels of the burner / boiler manufacturer and heating engineer against unauthorized access.

There is also a COM port which can be accessed from a superposed system, such as a building automation system.

On the BCI interface via interface OCI410, a PC can be connected with the PC software ACS410 (for dual fuel operation on request).

Among other features, the PC software ACS410 enables convenient readout of settings and operating states, parameterization of the LMV36 and trend recordings.

The burner / boiler manufacturer can select from different types of fuel trains and make use of a wide choice of individual parameter settings (program times, configuration of inputs / outputs, etc.), enabling him to make optimum adaptations to the relevant application. The actuators are driven by stepper motors and can be positioned with high resolution. Specific features and actuator settings are defined by the LMV36.

2.4 AGM60

The AGM60 connected to the LMV36 serves for changeover of valve control or for feedback signals from the 2 types of fuel. The signals are monitored by the LMV36 (same as with the single-fuel variant) which, in the event of fault, also triggers shutdown.

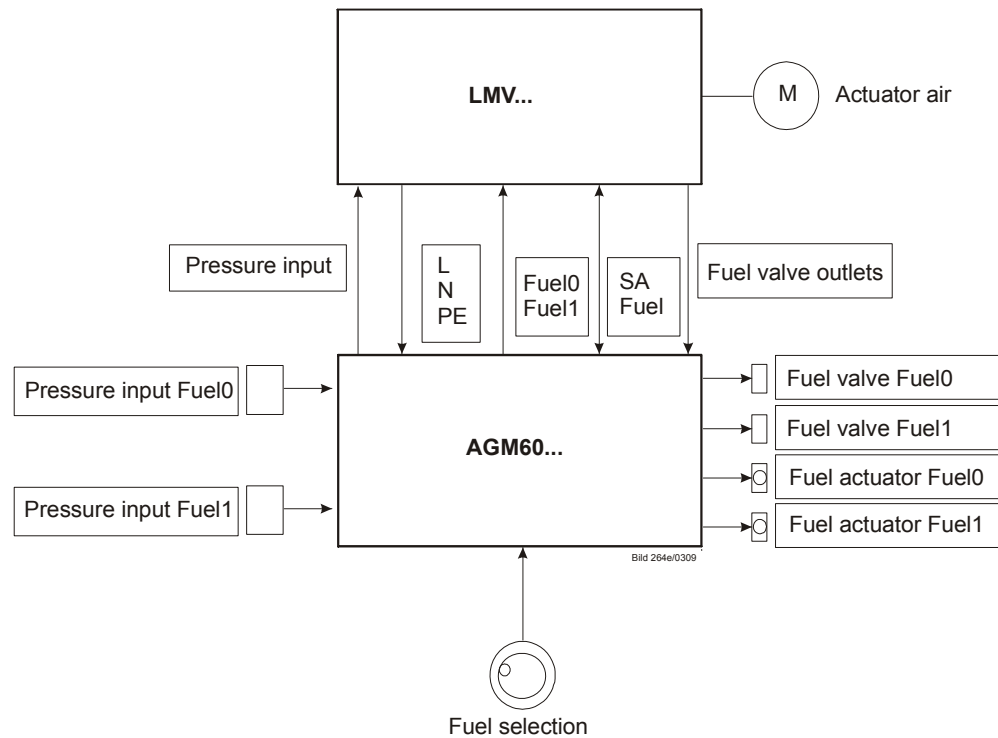

Figure 9: Connections of fuel actuators

2.4.1 Electrical connections of fuel actuators

When using only 1 fuel actuator, it must be connected directly to the LMV36. In that case, a connecting cable (AGV61.100) is not required.

When using 2 fuel actuators for each type, they must be connected to the AGM60.

Fuel selection choices:

- Gas / oil
- Gas / gas
- Oil / oil

When wiring the components, we recommend to make the following fuel assignments as standard:

Fuel 0 = gas

Fuel 1 = oil

This can be set via parameter 201 / 301 (refer to chapter *Selection of operating mode*).

Following switching's of inputs and outputs are made via AGM60:

- Fuel at the LMV36
- Fuel valve
- Pressure switch or POC
- Actuator (SQM3 or SQN1)

2.4.2 Continuous operation

The LMV36 together with the AGM60 is not approved for continuous operation.

In the case of intermittent operation in connection with the LMV36, an ionization probe or flame detector QRA, QRB or QRC can be used.

2.4.3 Fuel changeover

The fuel selection is made by an external connected switch at AGM60. The changeover logic of the AGM60 generates feedback signals *Fuel 0* and *Fuel 1* which are fed to the LMV36 for evaluation.



Note

Fuel changeover via the AZL2 or a building automation system is not technically possible.

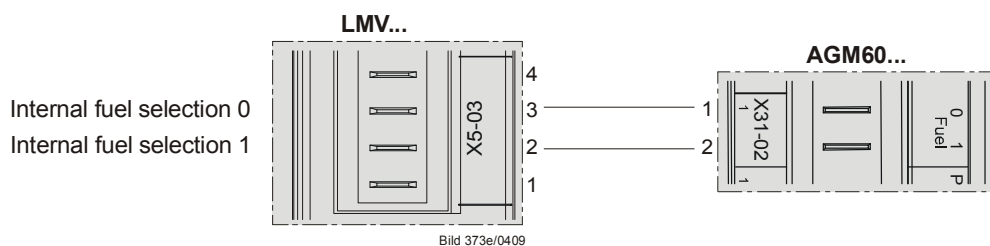

Figure 10: LMV36 with AGM60: Fuel changeover

The next burner start after shutdown or safety shutdown takes place with the **new** type of fuel.

After fuel changeover, any manually selected output or output called for by the building automation system is cancelled and automatic operation is activated, thus enabling automatic restart with the new fuel if there is a request for heat.

Exception:

The manual off function for manual output and burner off (output = 0) via the building automation system are maintained.

2.4.4 Extra fuel selector

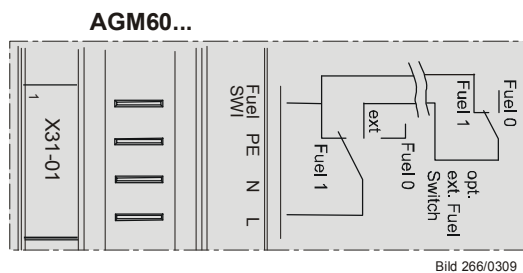

Figure 11: AGM60 extra fuel selector

3 Type summary

3.1 LMV36

Microprocessor-controlled LMV36 for single-fuel burners of any capacity for intermittent operation, with electronic fuel-air ratio control, with up to 2 actuators, integrated gas valve proving and VSD control.

Article no.	Type	Mains voltage	Parameter set	Flame detectors
BPZ:LMV36.520A1	LMV36.520A1	AC 120 V	North America	QRA2 / QRA4 / QRA10 / QRB / ION
S55402-C202-A100	LMV36.520A1UL	AC 120 V	US	QRA2 / QRA4 / QRA10 / QRB / ION

3.2 AGM60

The AGM60 is for connection to the LMV36 and used for changeover of valve control and/or for handling feedback signals from the 2 types of fuel.

Article no.	Type	Mains voltage
BPZ:AGM60.4A9	AGM60.4A9	AC 120 V

3.3 Fuel selector

The fuel selector is **not** a component of the AGM60 and does **not** constitute part of the scope of delivery.

4 Technical data

4.1 LMV36 basic unit

Mains voltage	AC 120 V -15 % / +10 %
Mains frequency	50 / 60 Hz \pm 6 %
Power consumption	<30 W (typically)
Safety class	I, with parts according to II and III to DIN EN 60730-1
Degree of protection	IP00 to DIN EN 60529
	Note The burner or boiler manufacturer must ensure degree of protection IP40 for the LMV36 as per DIN EN 60529 through adequate installation
Mode of operation	Type 2B in accordance with DIN EN 60730-1
Rated surge voltage	In accordance with DIN EN 60730-1 chapter 20 (OC III)
Voltage and current for the purposes of the EMC emitted interference tests	The emitted interference measurement test takes place with mains voltage and maximum power consumption

4.1.1 Terminal loading *Inputs*

• Perm. mains primary fuse (externally)	Max. 16 AT
• Unit fuse F1 (internally)	6.3 AT (DIN EN 60127 2 / 5)
• Mains supply: Input current depending on the operating state of the unit	
Undervoltage	
• Safety shutdown from operating position at mains voltage	Approx. AC 93 V
• Restart on rise in mains voltage	Approx. AC 96 V
Status inputs: Status inputs (with the exception of the safety loop) of the contact feedback network are used for system supervision and require mains-related input voltage	
• Input safety loop	Refer to <i>Terminal loading outputs</i>
• Input currents and input voltages	
- UeMax	UN +10 %
- UeMin	UN -15 %
- IeMax	1.5 mA peak
- IeMin	0.7 mA peak
• Contact material recommendation for external signal sources (air pressure switch, pressure switch-min, pressure switch-max, etc.)	Gold-plated silver contacts
• Transition / settling behavior / bounce	
- Perm. bounce time of contacts when switching on / off	Max. 50 ms (after the bounce time, contact must stay closed or open)
• UN	AC 120 V
• Voltage detection	
- On	AC 90...132 V
- Off	<AC 40 V

4.1.2 Terminal loading *Outputs*

Total contact loading:	
• Rated voltage	AC 120 V, 50 / 60 Hz
• Unit input current (safety loop) from:	Max. 5 A
- Fan motor contactor	
- Ignition transformer	
- Valves	
- Oil pump / magnetic clutch (optional via AGM60)	
Individual contact loading:	
Fan motor contactor	
• Rated voltage	AC 120 V, 50 / 60 Hz
• Rated current	1.6 A pilot duty output declaration to UL372
• Power factor	$\text{Cos}\phi > 0.4$
Alarm output	
• Rated voltage	AC 120 V, 50 / 60 Hz
• Rated current	1 A
• Power factor	$\text{Cos}\phi > 0.4$
Ignition transformer	
• Rated voltage	AC 120 V, 50 / 60 Hz
• Rated current	1.6 A pilot duty output declaration to UL372 or 250 VA ignition output declaration to UL372
• Power factor	$\text{Cos}\phi > 0.2$
Fuel valves	
• Rated voltage	AC 120 V, 50 / 60 Hz
• Rated current	1.6 A pilot duty output declaration to UL372
• Power factor	$\text{Cos}\phi > 0.4$
Operation display	
• Rated voltage	AC 120 V, 50 / 60 Hz
• Rated current	0.5 A
• Power factor	$\text{Cos}\phi > 0.4$
Safety valve (magnetic clutch / oil pump)	
• Rated voltage	AC 120 V, 50 / 60 Hz
• Rated current	1.6 A pilot duty output declaration to UL372
• Power factor	$\text{Cos}\phi > 0.4$
Connections for pressure switch	
• Rated voltage	AC 120 V, 50 / 60 Hz
• Rated current	1.5 mA
• Power factor	---
Power supply for pressure switch-max / POC (X5-02 pin 3 or X22-02 pin 3)	
• I _{aMax}	<10 mA
Fuel feedback to LMV36 (X31-02 pin 1 or X31-02 pin 2)	
• I _{aMax}	<10 mA

4.1.3 Analog output / load output X74 pin 3

Accuracy of output voltage	±1%
----------------------------	-----

4.1.4 Cable lengths

• Mains line AC 120 V	Max. 100 m (100 pF/m)
• Display, BC interface	For installation under the burner hood or in the control panel Max. 3 m (100 pF/m)
• Load controller X5-03	Max. 20 m (100 pF/m)
• Load controller analog X64 (24 mA)	Max. 20 m (100 pF/m)
• Safety loop / burner flange (total)	Max. 20 m (100 pF/m)
• External lockout reset button	Max. 20 m (100 pF/m)
• Safety valve	Max. 20 m (100 pF/m)
• Power output ¹⁾	Max. 10 m (100 pF/m)
• VSD control ¹⁾²⁾	Max. 3 m (100 pF/m)
• Speed input	Max. 3 m (100 pF/m)
• Fuel valve V1 / V2 / V3	Max. 3 m (100 pF/m)
• Pilot valve	Max. 3 m (100 pF/m)
• Ignition transformer	Max. 3 m (100 pF/m)
• Other lines	Max. 3 m (100 pF/m)

¹⁾ Do not run the cable together with other cables. If not observed, hum voltage might cause electromagnetic interference

²⁾ Shorter cable length due to closed control loop

Specification as per EN 60730-1

Type of shutdown or interruption of each circuit

Shutdown with microswitch 1-pole

Mode of operation Type 2 B

4.1.5 Cross-sectional areas

The cross-sectional areas of the mains power lines (L, N, and PE) and, if required, the safety loop (safety limit thermostat, water shortage, etc.) must be sized for rated currents according to the selected external primary fuse. The cross-sectional areas of the other cables must be sized in accordance with the internal unit fuse (max. 6.3 AT).

Min. cross-sectional area	0.75 mm ² (single- or multi-core as per VDE 0100)
---------------------------	---

Cable insulation must meet the relevant temperature requirements and environmental conditions.

Fuses (F1) used inside LMV36	6.3 AT DIN EN 60127 2 / 5
------------------------------	---------------------------

4.1.6 Connections of actuators

The ready connected actuator cables must not be extended.

4.2 Signal cable AGV50 from AZL2 → BC interface

Signal cable	Color white Unshielded Conductor 4 x 0.141 mm ² With RJ11 connector
Cable length	
- AGV50.100	1 m
- AGV50.300	3 m
Location	Under the burner hood (extra measures required for SKII EN 60730-1)

4.3 Environmental conditions

Storage	DIN EN 60721-3-1
Climatic conditions	Class 1K3
Mechanical conditions	Class 1M2
Temperature range	-20...+60 °C
Humidity	<95 % r.h.
Transport	DIN EN 60721-3-2
Climatic conditions	Class 2K2
Mechanical conditions	Class 2M2
Temperature range	-30...+60 °C
Humidity	<95 % r.h.
Operation	DIN EN 60721-3-3
Climatic conditions	Class 3K3
Mechanical conditions	Class 3M3
Temperature range	-20...+60 °C
Humidity	<95 % r.h.
Installation altitude	Max. 2,000 m above sea level



Caution!

Condensation, formation of ice and ingress of water are not permitted!

4.4 Flame detectors

4.4.1 Ionization probe

For continuous operation!

No-load voltage at ION terminal (X10–05 pin 2)	Approx. U_{Mains}
---	----------------------------



Caution!

The ionization probe must be protected against electric shock hazard!

Short-circuit current	Max. AC 1 mA
Required detector current	Min. DC 2.3 μA , flame display approx. 30%
	When the more sensitive flame supervision is activated, the required detector current is halved (see chapter <i>Flame detection sensitivity</i>).
Possible detector current	Max. DC 12...30 μA , flame display approx. 100 %
Max. perm. length of detector cable (laid separately)	3 m (wire-ground 100 pF/m)



Warning!

Simultaneous operation of QRA and ionization probe is not permitted!



Note

The higher the detector cable's capacitance (cable length), the more voltage at the ionization probe, and thus the detector current, drops. Long cable lengths plus very highly resistive flames might necessitate low-capacitance detector cables (e.g. ignition cable). In spite of technical measures taken in the circuitry aimed at compensating potential adverse effects of the ignition spark on the ionization current, it must be made certain that the minimum detector current required is already reached during the ignition phase. If this is not the case, the connections on the primary side of the ignition transformer must be changed and / or the electrodes relocated.

Threshold values when flame is supervised by an ionization probe:

- Start prevention (extraneous light)	Intensity of flame (parameter 954) $\geq 18\%$
- Operation	Intensity of flame (parameter 954) $> 24\%$

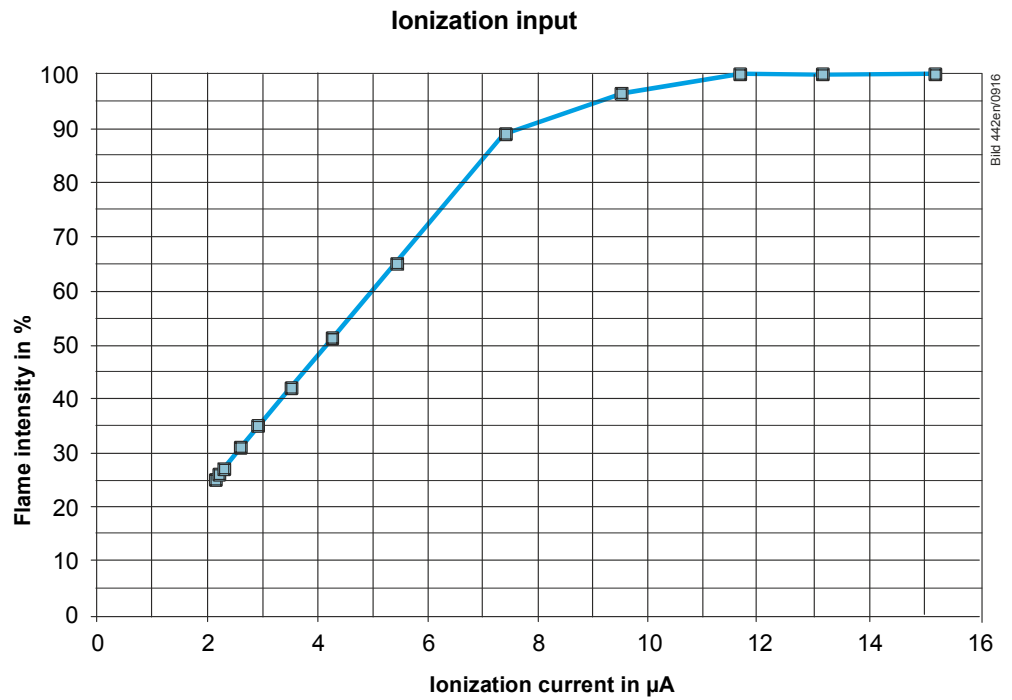

Figure 12: Ionization input at AC 120 V

Measuring circuit for
detector current
measurement

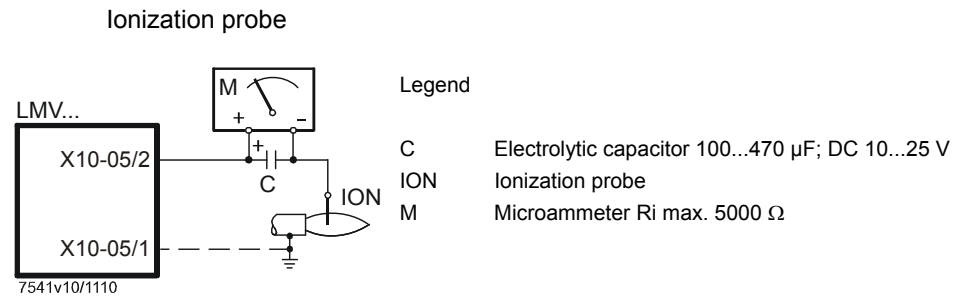

Figure 13: Measuring circuit for ionization probe

4.4.2 UV flame detectors QRA2 / QRA4 / QRA10



Caution!

If QRA2-UV tubes / QRA4-UV tubes / QRA10-UV tubes are used for flame supervision on the LMV36, it must be ensured that the LMV36 is permanently connected to power (EN 298), thus enabling the LMV36 to detect flame detector failures during startup and shutdown.

Generally, the LMV36 works with QRA flame detectors in intermittent operation. For technical data, refer to Data Sheet N7712 covering QRA2 / QRA10 UV flame detector!

For technical data, refer to Data Sheet N7711 covering QRA4 UV flame detector!

Operating voltage	Max. 350 V peak
Required detector current in operation	Min. 30 μ A
	When the more sensitive flame supervision is activated, the required detector current is halved (see chapter <i>Flame detection sensitivity</i>).
Possible detector current in operation	Max. 600 μ A
Permissible length of flame detector cable - normal cable (laid separately)	Max. 6 m
Threshold values when flame is supervised by QRA:	
- Start prevention (extraneous light)	Intensity of flame (parameter 954) \geq 18%
- Operation	Intensity of flame (parameter 954) $>$ 24%

Measuring circuit for detector current measurement

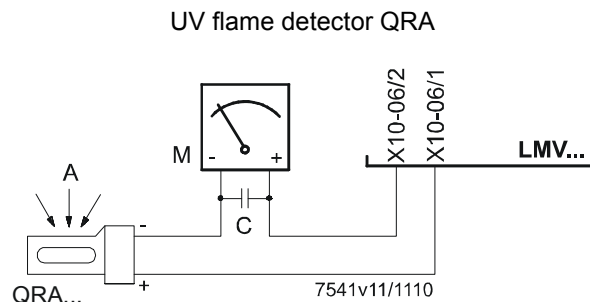

Figure 14: Measuring circuit QRA

Legend

- A Incidence of light
- C Electrolytic capacitor 100...470 μ F; DC 10...25 V
- M Microammeter R_i max. 5000 Ω



Warning!

- Input QRA is not short-circuit-proof!
Short-circuits of X10-06 pin 2 against earth can destroy the QRA input
- Simultaneous operation of QRA and ionization probe is not permitted!

4.4.3 Photoresistive flame detectors QRB1 / QRB3

No-load voltage at QRB1/QRB3 terminal (X10-05 pin 3)	Approx. DC 5 V
Max. perm. length of QRB1/QRB3 detector cable (laid separately)	3 m (wire – wire 100 pF/m)



Note

A detector resistance of $R_F < 500 \Omega$ is identified as a short-circuit and leads to safety shutdown in operation as if the flame had been lost.

For this reason, before considering the use of a highly sensitive photoresistive detector (QRB1B or QRB3S), it should be checked whether this type of flame detector is indeed required! Increased line capacitance between QRB1/QRB3 connection and mains live wire L has an adverse effect on the sensitivity and increases the risk of damaged flame detectors due to overvoltage. Always run detector cables separately!

Threshold values when flame is supervised by QRB1/QRB3:

Start prevention (extraneous light) with R_{QRB}	$< 400 \text{ k}\Omega$ Intensity of flame $\geq 10\%$
Operation with R_{QRB}	$< 230 \text{ k}\Omega$ Intensity of flame $> 16\%$
Short-circuit detection with R_{QRB}	$< 0.5 \text{ k}\Omega$

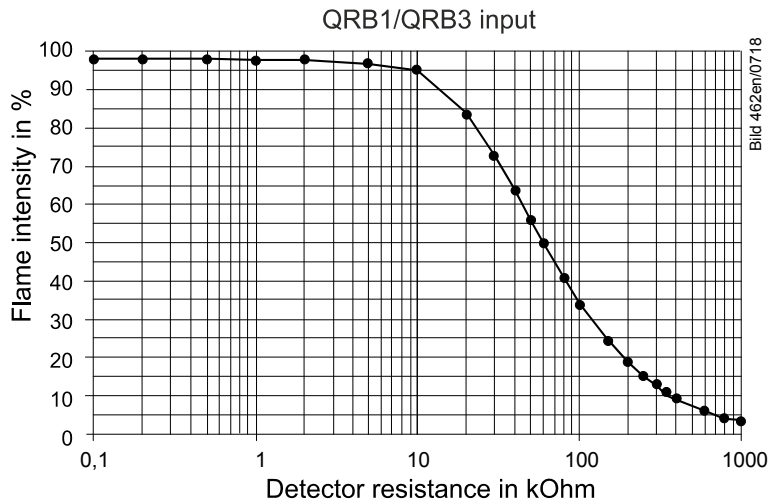

Figure 15: QRB1/QRB3 input at AC 230 V

A flame detector resistance of $R_F < 500 \Omega$ is identified as a short-circuit and leads to safety shutdown in operation, like in the case of loss of flame.

4.4.4 Yellow flame detector QRB4

Open-circuit voltage at terminal QRB4 (X10-05 pin 3)	Approx. 5 V DC
Permissible length of QRB4 detector cable (laid separately)	3 m (wire to wire 100 pF/m)
Threshold values when flame is supervised by QRB4	
Start prevention (extraneous light)	Flame intensity (parameter 954) $\geq 10\%$
Operation	Flame intensity (parameter 954) $> 16\%$



Note!

In the case of the QRB4, the maximum intensity display is limited to approximately 40% due to the system (parameter 954).



Note!

Connection of QRB4 cables!

Blue cable of QRB4 to terminal X10-05 pin 4.
Black cable of QRB4 to terminal X10-05 pin 3.
Otherwise, the QRB4 will not work.

4.5 Switch unit AGM60

Mains voltage	AC 120 V -15% / +10%
Mains frequency	50/60 Hz ±6%
Power consumption	<5 W (typically) (without actuator supply)
Safety class	I with parts according to II and III to DIN EN 60730-1
Galvanic separation between mains voltage terminals and actuator signal lines and actuator supply lines	No
Degree of protection	IP00
	<p> Note! The burner or boiler manufacturer (OEM) must ensure degree of protection IP40 to DIN EN 60529 for burner controls by adequate installation of the AGM60.</p> <p>The AGM60 together with the LMV36 is suited for installation under the burner hood or inside a control cabinet or control panel</p>
Detection time fuel changeover	<400 ms
Switching frequency fuel changeover	Min. 3 s
Switching cycles fuel changeover	Max. 5'000
Perm. mains primary fuse (externally)	Max. 6.3 AT Power must always be supplied via the LMV36 (refer to chapter <i>Inputs / Outputs</i>)
Mains supply:	
Input current depending on the operating state of the unit	
Mains voltage is monitored by the LMV36	
Dimensions (W x H x D)	180.7 x 120.7 x 51.7 mm
Mounting	Top hat rail to DIN EN 60715, 35 mm or screwed

4.5.1 Terminal output *Inputs*

Status input: Fuel selection, pressure switch	
• Input currents and input voltages	
- UeMax	UN +10%
- UeMin	UN -15%
- IeMax	1.5 mA peak
- IeMin	0.7 mA peak
• Contact material recommendation for external switching contact, transducer (pressure switch-max, POC)	Gold-plated silver contacts
• Transition / settling behavior / bounce	
- Perm. bounce time of contacts when switching on/off	Max. 50 ms (after the bounce time, the contact must stay closed or open)
• UN	AC 120 V
• Voltage detection	
- On	AC 90...132 V
- Off	<AC 40 V

4.5.2 Terminal output *Outputs*

Total contact output:	
• Rated voltage	AC 120 V, 50/60 Hz
Refer also <i>Total contact output</i> in chapter <i>Terminal output Outputs</i>	
Individual contact loads:	
Fuel valve	
• Rated voltage	AC 120 V, 50/60 Hz
• Rated current	1.6 pilot duty output declaration to UL732
• Power factor	Cosφ >0.4
Safety valve (magnetic clutch / oil pump)	
• Rated voltage	AC 120 V, 50/60 Hz
• Rated current	1.6 A pilot duty output declaration to UL732
• Power factor	Cosφ >0.4
Connections for pressure switch	
• Rated voltage	AC 120 V , 50/60 Hz
• Rated current	1.5 mA
• Power factor	---
Power supply for pressure switch-max / POC (X5-02 pin 3 or X22-02 pin 3)	
• IaMax	<10 mA
Fuel feedback to LMV36 (X31-02 pin 1 or X31-02 pin 2)	
• IaMax	<10 mA

4.5.3 Cable lengths

• Mains line LMV36 → AGM60	Max. 3 m (100 pF/m)
• Fuel valves	Max. 3 m (100 pF/m)
• Other lines	Max. 3 m (100 pF/m)
• Fuel selector	Max. 20 m (100 pF/m)
• Load controller	Max. 20 m (100 pF/m)

Specification as per EN 60730-1

Type of shutdown or interruption of each circuit	
Shutdown with microswitch	Single-pole
Mode of operation	Type 2 B

4.5.4 Cross-sectional areas

The cross-sectional areas of the power supply lines (L, N and PE) must be capable of carrying the rated currents according to the built-in unit fuse of the respective LMV36 (max. 6.3 AT).

Cross-sectional area	Min. 0.75 mm ² (single- or multi-core to VDE 0100)
----------------------	--

Cable insulations must satisfy the relevant temperature requirements and environmental conditions.

4.5.5 Electrical connections of actuators

The ready connected actuator cables must not be extended.

4.5.6 Environmental conditions

Storage	DIN EN 60721-3-1
Climatic conditions	Class 1K3
Mechanical conditions	Class 1M2
Temperature range	-20...+60 °C
Humidity	<95% r.h.
Transport	DIN EN 60721-3-2
Climatic conditions	Class 2K2
Mechanical conditions	Class 2M2
Temperature range	-30...+60 °C
Humidity	<95% r.h.
Operation	DIN EN 60721-3-3
Climatic conditions	Class 3K3
Mechanical conditions	Class 3M3
Temperature range	-20...+60 °C
Humidity	<95% r.h.
Installation altitude	Max. 2,000 m above sea level



Caution!
Condensation, formation of ice and ingress of water are not permitted!

5 Dimensions

5.1 LMV36

Dimensions in mm

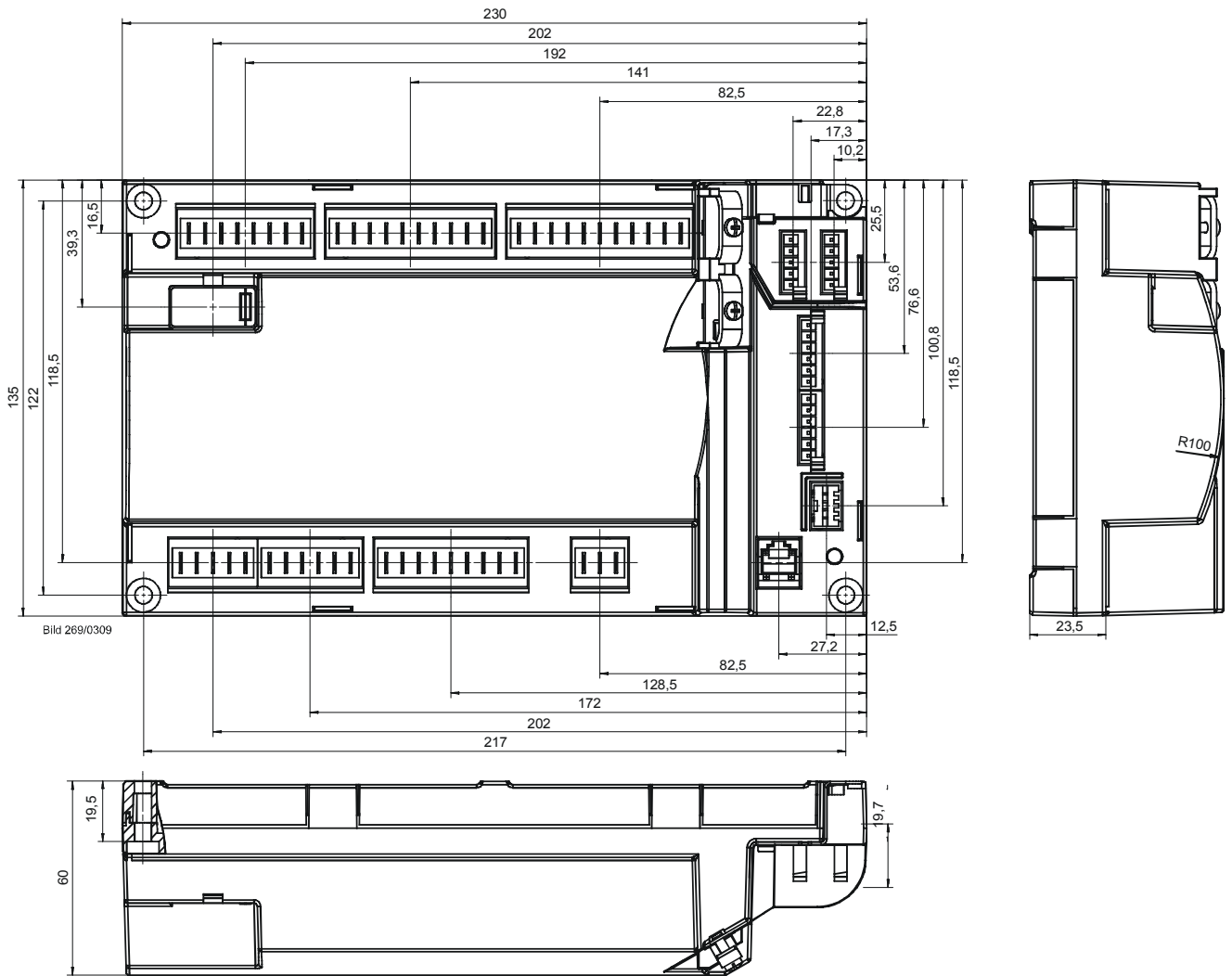

Figure 16: Dimensions of the LMV36

5.2 AGM60

Dimensions in mm

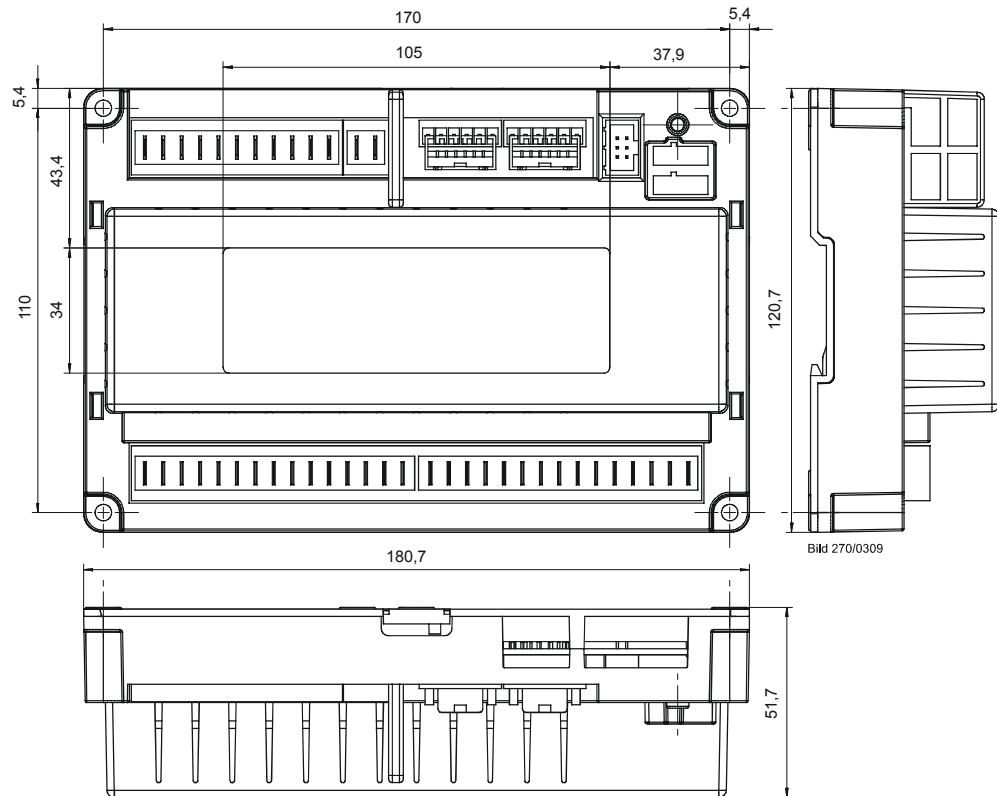

Figure 17: Dimensions of the AGM60

6 Display and diagnostics

Transmission of operating states, fault status messages and detailed service information via:

BC interface communication via integrated RJ11 jack to the AZL2 display and operating unit, or via additional OCI410 interface to ACS410 PC software.

Communication / parameterization

AZL2

The AZL2 offers ease of operation, parameterization and targeted diagnostics via features menu-driven operation. When making diagnostics, the display shows operating states, the type of error and startup meter reading. Passwords protect the different parameter levels of the burner / boiler manufacturer and heating engineer against unauthorized access.

ACS410 PC software

ACS410 PC software enabled a simple operation, comfortable readout of settings and operating states, the parameterization, trend recording and targeted diagnostic of LMV36.

For this purpose, the OCI410 interface for communication with the LMV36 is connected to the PC. This interface is available separately and is connected to the integrated RJ11 jack.

7 Basic unit LMV36

7.1 Description of inputs and outputs

This chapter covers the key features of the LMV36 inputs and outputs. For exact use of the inputs and the activation of outputs, refer to chapter *Sequence diagrams*.

Flame signal input and flame detector X10-05 and X10-06

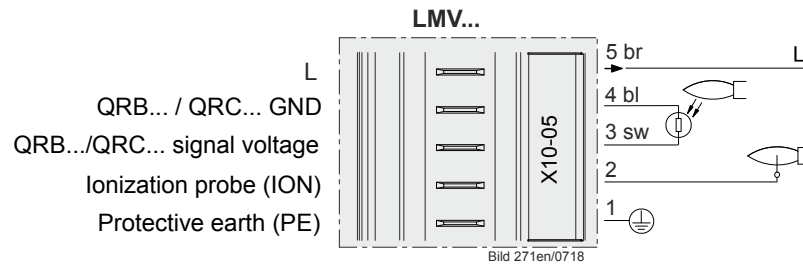

Figure 18: Flame signal input X10-05

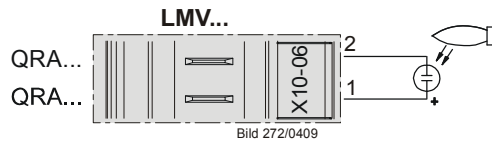

Figure 19: Flame signal input X10-06

Connection choices:

- Ionization probe
- QRA2 / QRA10
- QRA4
- QRB

7.2 Flame detectors

For display of the flame on the AZL2, the following general conditions apply:

- Display is subject to various component tolerances, which means that deviations of $\pm 10\%$ can occur
- Note that, for physical reasons, there is no linear relationship between flame display and detector signal values

The LMV36 can be used with different types of flame detectors. For the correct use of flame detectors, refer to chapter *Sequence diagrams*.

The flame detector used must be correctly parameterized.



Caution!

Continuous operation is possible only when using an ionization probe!

In the hardware of the LMV36, the flame signals are subdivided into 2 groups (group 0 covering types the QRB and group 1 covering ionization and the QRA). The flame detector for gas is selected via parameter 221 / 321 (fuel 1), that for oil via parameter 261 / 361 (fuel 1).

No.	Parameter
221	Gas: Active detector flame evaluation 0 = QRB / QRC 1 = ION / QRA
261	Oil: Active detector of flame evaluation 0 = QRB / QRC 1 = ION / QRA
321	Fuel 1 gas: Active detector of flame evaluation 0 = QRB / QRC 1 = ION / QRA
361	Fuel 1 oil: Active detector of flame evaluation 0 = QRB / QRC 1 = ION / QRA

7.2.1 Loss of flame

In the event of loss of flame, the unit initiates safety shutdown, followed by a restart, if required. A repetition counter can be used to select the number of flame losses after which the unit shall initiate lockout (refer to chapter *Repetition counter*).

Error code	Diagnostic code	Meaning for the LMV36
7	0	Loss of flame

No.	Parameter
186	Software drop out delay time of flame signal (100 ms) Index 0 = QRB / QRC (0 = deactivated, >1 = activated) Index 1 = ION / QRA (0 = deactivated, >3 = activated) (only 200 ms-steps)
187	Fuel 1: Software drop out delay time of flame signal (100 ms) Index 0 = QRB / QRC (0 = deactivated, >1 = activated) Index 1 = ION / QRA (0 = deactivated, >3 = activated) (only 200 ms-steps)
194	Repetition limit no flame at the end of safety time 1 = no repetition 2...4 = 1...3 repetitions Recharging time: Entering into operation
240 280 340 380	Repetition limit value loss of flame 1 = no repetition 2 = 1 repetition Recharging time: After the <i>Operation</i> phase



Caution!

The response time of the flame detector leads to an extension of the second safety time. This must be taken into account when designing the burner!

7.2.2 Extraneous light

Extraneous light during standby (phase 12) leads to prevention of startup, followed by a restart. Extraneous light during the prepurge phase results in immediate lockout. If extraneous light occurs during the shutdown phase, the LMV36 switches to the safety phase.

One repetition is permitted. This means that if the error occurs again the next time the system is shut down, the unit will initiate lockout.

Error code	Diagnostic code	Meaning for the LMV36
4	0	Extraneous light during startup
	1	Extraneous light during shutdown
	2	Extraneous light during startup – prevention of startup

7.2.3 No flame at the end of safety time

If no flame is established by the end of the first safety time, the unit initiates lockout.

Error code	Diagnostic code	Meaning for the LMV36
2	1	No flame at end of the first safety time
	2	No flame at end of the second safety time

7.2.4 Flame intensity

The flame's intensity can be displayed. It is standardized from 0 to 100%.

No.	Parameter
954	Intensity of flame



Note

Also refer to chapter *Intensity of flame during curve settings*.

7.2.5 Supervision of flame detector

Error code	Diagnostic code	Meaning for the LMV36
93	3	Short-circuit of flame detector

At the QRB flame detector's input, the LMV36 checks the detector for short-circuits in operation.

7.2.6 Flame detection sensitivity

For applications with a high degree of modulation (e.g. 1:15 / 1:20), it may be necessary to increase the flame detection sensitivity. This can be carried out via parameters for flame detection with ionization probe or UV flame detector QRA.

The ignition (phases 40...52) always takes place with standard flame sensitivity.

The high flame sensitivity for ionization probe or QRA is only activated during operation (from phase 60).

This means that the ignition load must be set so that the burner ignites reliably with regular flame sensitivity.

It is also possible to deactivate the more sensitive flame detection for the output range above the ignition point (default setting curvepoint P4, i.e. 50% of the theoretical output of the LMV36).

No.	Parameter
197	Setting the flame signal sensitivity ionization probe / QRA in operation (\geq phase 60) 0 = standard 1 = approx. twice as high sensitivity
198	Maximum output for high flame sensitivity 2 = no maximum output for high flame sensitivity 3...9 = deactivation of the high flame sensitivity from the curvepoint P3...P9

7.3 Digital inputs

7.3.1 Safety loop X3-04 (optional pressure switch-max), pin 1 and 2

Input for connection of the safety loop. When any of the series-connected contacts included in the loop opens, power supply to the fuel valves, the fan and the ignition equipment is instantly cut.

The safety loop includes the following components:

- External burner switch (ON / OFF)
- Safety limiter / safety pressure limiter
- External control thermostat and / or pressurestat, if required
- Water shortage switch



Note

Pressure switch-max when using POC via X5-02.

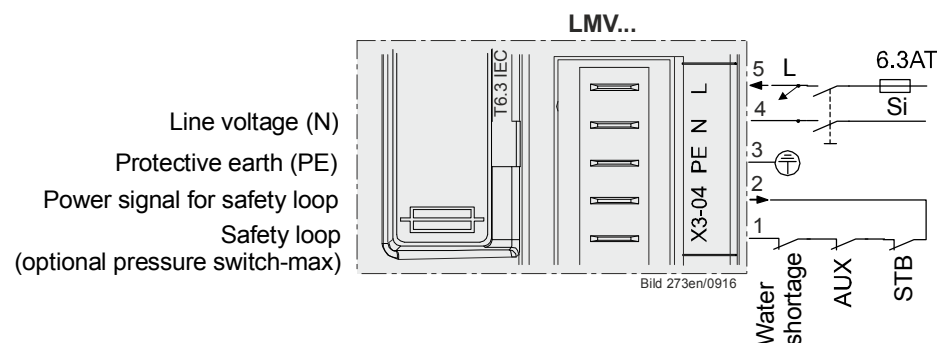

Figure 20: Safety loop (optional pressure switch-max) X3-04

For diagnostic purposes, the contacts of the components included in the safety loop and the burner flange contact are combined for delivering the safety loop signal. If there is no such signal, the system initiates safety shutdown in any event.

If, with *Load controller ON*, there is no signal from the safety loop (start prevention), error code 22 is translated to text display **OFF S** (S = safety loop) and the numerical value appears in the error history.

Error code	Diagnostic code	Meaning for the LMV36
22 OFF S	0	Safety loop / burner flange Open

For the input, a repetition counter can be parameterized. Here, it is possible to set the number of errors permitted until lockout occurs (refer to chapter *Repetition counter*).

No.	Parameter
215	Repetition limit safety loop 1 = no repetition 2...15 = 1...14 number of repetitions 16 = constant repetition Recharging time: Every 24 hours



Attention!

In the safety loop, temporarily (<1 s) switching contacts must not be wired (switch or other)!

7.3.2 Burner flange X3–03, pin 1 and 2

End switch burner flange (component of safety loop).

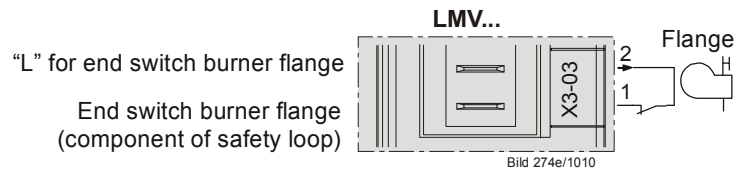

Figure 21: Burner flange X3-03

For error diagnostics and parameters, refer to chapter *Safety loop*.

7.3.3 Input for external load controller (ON / OFF) X5–03, pin 1

When the external control loop is closed, the internal input message *Heat request* is generated.

A heat request exists when the external load controller signal is pending and, depending on the configuration, a load controller calls for heat (refer to chapter *Connection of load controllers*).

When there are no more requests for heat, the burner shuts down. The fuel valves are closed, either immediately when the timer has elapsed, or when the low-fire position is reached, depending on the parameter settings (refer to chapter *End of operating position*).



Note

Burner startup takes place only when this contact is closed.

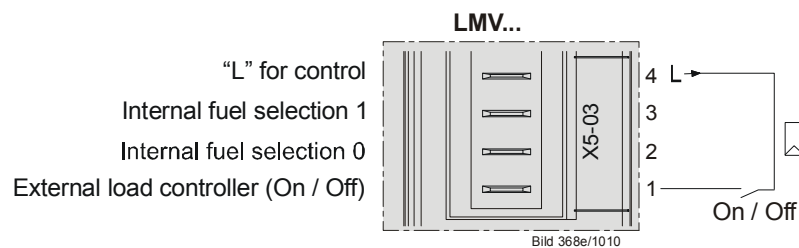

Figure 22: Inputs for external load controller ON / OFF X5-03

7.3.4 Air pressure switch X3-02

Input for connection of an air pressure switch: Air pressure is anticipated when the fan is switched on. If there is no air pressure signal, the system initiates lockout. The air pressure switch must have an NO contact.

If no air pressure switch is required (e.g. when firing on oil), a wire link to the fan output must be fitted (between X3-02, pin 1, and X3-05, pin 1).



Caution!

The OEM must check to see whether the burner can be operated without air pressure switch. This may necessitate a special approval, depending on the type of application.

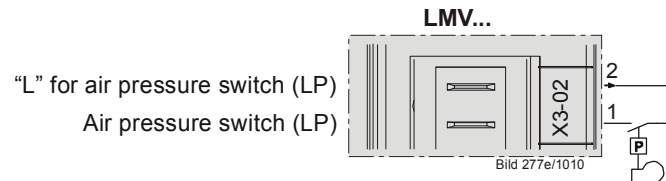

Figure 23: Air pressure switch X3-02

No.	Parameter
235	Air pressure switch 1 = active 2 = active, except phase 60...66 / 70...72 (pneumatic operation only)
335	Fuel 1: Air pressure switch 1 = active 2 = active, except phase 60...66 / 70...72 (pneumatic operation only)

Error code	Diagnostic code	Meaning for the LMV36
3	0	Air pressure off
	1	Air pressure on
	4	Air pressure on – prevention of startup

For the input, a repetition counter can be parameterized. Here, it is possible to set the number of errors that are permitted until lockout occurs (refer to subsection *Repetition counter*).

No.	Parameter
196	Repetition limit air pressure failure 1 = no repetition 2 = 1 repetition 3 = 2 repetitions Recharging time: End of <i>Shutdown</i> phase / 24 hours continuous operation

7.3.5 Gas pressure switch for gas valve proving X9-04

Input for connection of *Pressure switch valve proving X9-04*.

The input is active only when firing on gas and when the valve proving is activated (refer to chapter *Program sequence*).

No.	Parameter
241	Gas: Execution valve proving 0 = no valve proving 1 = valve proving on startup 2 = valve proving on shutdown 3 = valve proving on startup and shutdown
341	Fuel 1 gas: Execution valve proving 0 = no valve proving 1 = valve proving on startup 2 = valve proving on shutdown 3 = valve proving on startup and shutdown

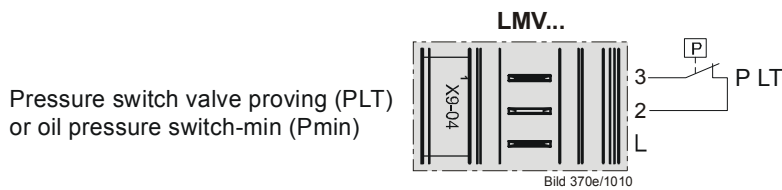

Figure 24: LMV36: Pressure switch valve proving gas X9-04

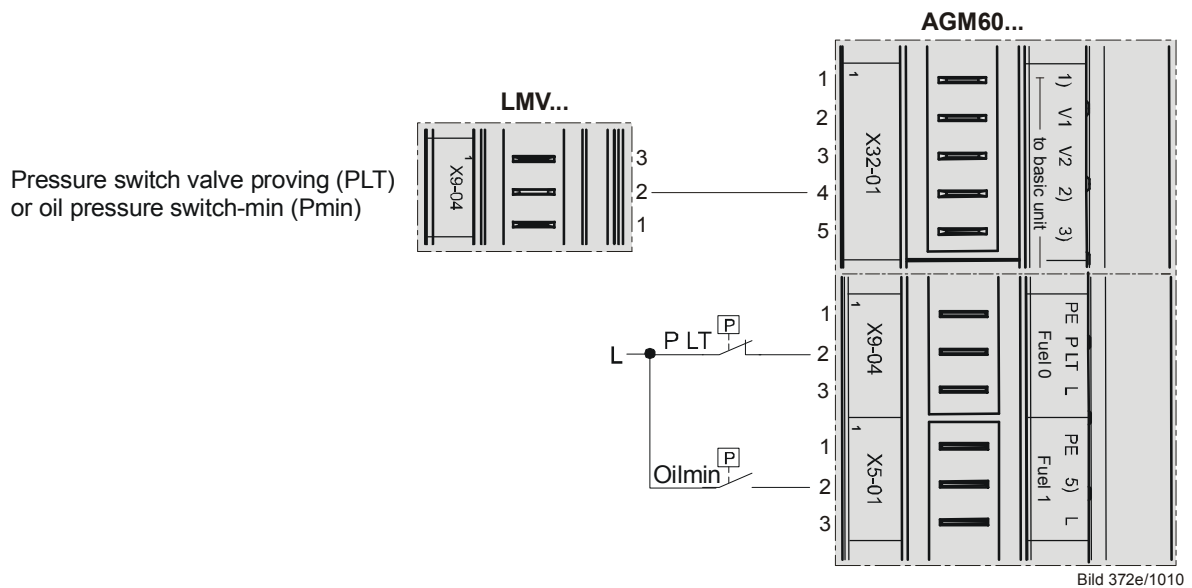

Figure 25: LMV36 with AGM60: Pressure switch valve proving gas X9-04

Pressure switch valve proving

Input for connection of valve proving with own pressure switch.

The input is active only when valve proving is activated.

Error code	Diagnostic code	Meaning for the LMV36
12	81	Fuel valve V1 leaking
	83	Fuel valve V2 leaking



Note

When using configuration *Valve proving* via gas pressure switch-min, it is not possible to use the input for *Start release gas*.

7.3.6 Gas pressure switch-min, start release gas X5-01

Input for connection of a pressure switch-min for gas: If the plant does not require a pressure switch-min, a wire link must be fitted between pin 2 and 3.

Gas pressure switch-min

The LMV36 enables parameterization of which gas train position the gas pressure switch-min is mounted on. This also influences the time of the input evaluation.

No.	Parameter
236	Gas: Input pressure switch-min 1 = pressure switch-min before fuel valve V1 (default setting) 2 = valve proving via pressure switch-min (between fuel valve V1 and fuel valve V2) 3 = pressure switch-min after fuel valve V2
336	Fuel 1 gas: Input pressure switch-min 1 = pressure switch-min before fuel valve V1 (default setting) 2 = valve proving via pressure switch-min (between fuel valve V1 and fuel valve V2) 3 = pressure switch-min after fuel valve V2

In all types of gas trains, the minimum gas pressure is expected from phase 22 in the default setting (value 1).

If no gas pressure is detected when the maximum time (parameter 214) has elapsed, the gas shortage program is started (refer to chapter *Gas shortage program*).

If value 2 is set, the gas shortage check only takes place in phase 39 or in conjunction with a potential valve proving as part of commissioning. When the gas pressure switch-min is mounted after the fuel valves, a gas shortage check cannot be carried out. The supervision of the gas pressure is only carried out from phase 40 (direct ignition) or from phase 50 (pilot ignition) depending on the fuel train used.

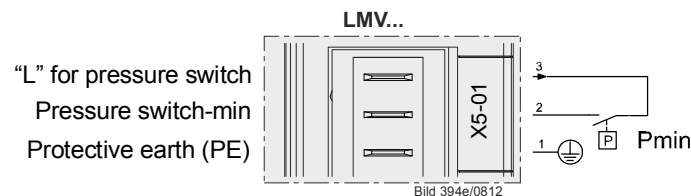

Figure 26: Gas pressure switch-min X5-01



Caution!

The OEM must check to see whether the burner can be operated without pressure switch-min. This may necessitate a special approval, depending on the type of application.

No.	Parameter
214	Maximum time start release
285	Oil: Gas pressure switch-min with «LoGp» 0 = inactive 1 = active

During the safety times, the signal received from pressure switch-min is only assessed after a certain period of time in order to ignore the pressure shocks that occur the moment the valves open. The time to elapse for signal assessment can be parameterized.

No.	Parameter
229	Gas: Time to respond to pressure faults in the first and second safety time
329	Fuel 1 gas: Time to respond to pressure faults in the first and second safety time

If the gas pressure fails, at least a shutdown will be initiated.

Error code	Diagnostic code	Meaning for the LMV36
20	0	Pressure switch-min No minimum gas pressure
20	1	Gas shortage start prevention
23	0	Pressure switch-min No minimum gas pressure
23	1	Gas shortage start prevention

For the input, a repetition counter can be parameterized. It can be used to set the number of errors permitted until lockout occurs. The counter also impacts the gas shortage program (refer to chapter *Repetition counter*).

No.	Parameter
223 323	Repetition limit value gas pressure switch-min 1 = no repetition 2...15 = 1...14 number of repetitions 16 = constant repetition Recharging time: After the <i>Operation</i> phase

Start release gas

If, at the same time, the input is used as a start release input (e.g. for an air supply damper), it can be connected in series with the pressure switch.

When selecting *Valve proving via pressure switch-min* (parameter 236), function *Start release gas* is not supported.

No.	Parameter
236	Gas: Input pressure switch-min 1 = pressure switch-min before fuel valve V1 (default setting) 2 = valve proving (between fuel valve V1 and fuel valve V2) via pressure switch-min 3 = pressure switch-min after fuel valve V2

7.3.7 Oil pressure switch-min X9-04 (X5-01 on AGM60)

Input for connection of a pressure switch-min for oil: If the plant does not require a pressure switch-min, a wire link between terminal 2 and terminal 3 must be fitted.



Caution!

The OEM must check to see whether the burner can be operated without using a pressure switch-min. This may necessitate a special approval, depending on the application.

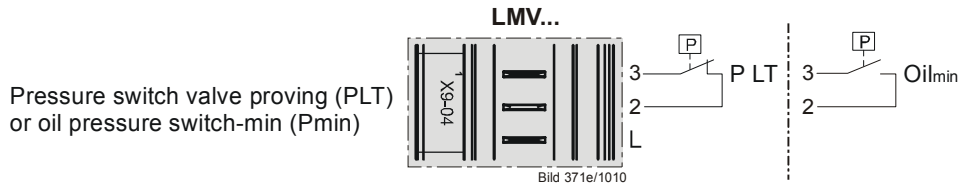

Figure 27: LMV36: Oil pressure switch-valve proving X9-04

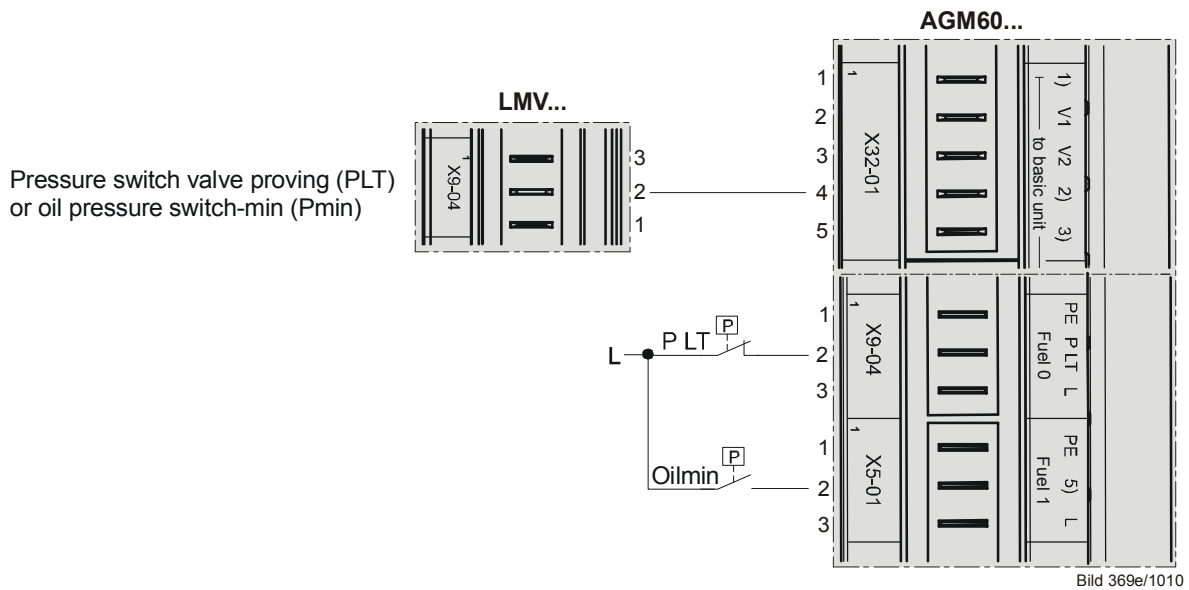

Figure 28: LMV36 with AGM60: Oil pressure switch-valve proving X5-01

Oil pressure switch-min

In all types of oil train, the minimum oil pressure is expected from phase 38. If no oil pressure is detected when the maximum time (parameter 217) has elapsed or if, subsequently, the oil pressure drops, the system initiates lockout.

No.	Parameter
217	Maximum wait time for detecting a detector signal or pressure switch signal (e.g. home run, preignition)

Error code	Diagnostic code	Meaning for the LMV36
20	0	Pressure switch-min No min. oil pressure
20	1	Gas shortage start prevention

During the safety times, the signal from pressure switch-min is only assessed after a certain period of time in order to ignore the pressure shocks that occur the moment the valves open. The time to elapse for signal assessment can be parameterized.

No.	Parameter
269	Oil: Time to respond to pressure faults in the first and second safety time
369	Fuel 1 oil: Time to respond to pressure faults in the first and second safety time

7.3.8 Setting the time for checking the pressure switch

For oil pressure switch-min, the point in time from which the check is made can be set via parameter 276 (active from phase 38, or from safety time).

No.	Parameter
276	Oil: Input pressure switch-min 1 = active from phase 38 2 = active from safety time
376	Fuel 1 Oil: Input pressure switch-min 1 = active from phase 38 2 = active from safety time

7.3.9 Gas / oil pressure switch-max / or POC contact, start release oil / additional speed-dependent air pressure switch X5-02

Input for connection of a pressure switch-max for gas or oil: The sensor must have an NC contact, which means that the contact opens when the adjusted maximum pressure is exceeded. If the plant does not require a pressure switch-max, a wire link must be fitted between pin 2 and 3.



Caution!
The OEM must check to see whether the burner can be operated without pressure switch-max. This may necessitate a special approval, depending on the type of application.

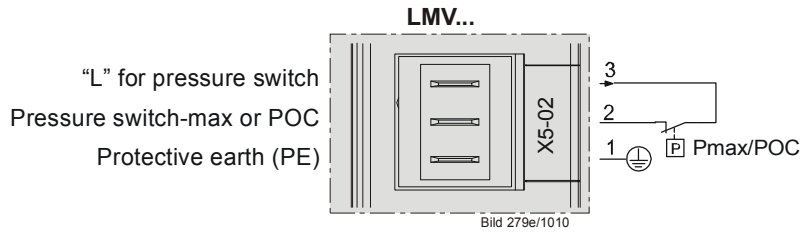

Figure 29: LMV36: Gas / oil Pressure switch-max or POC X5-02

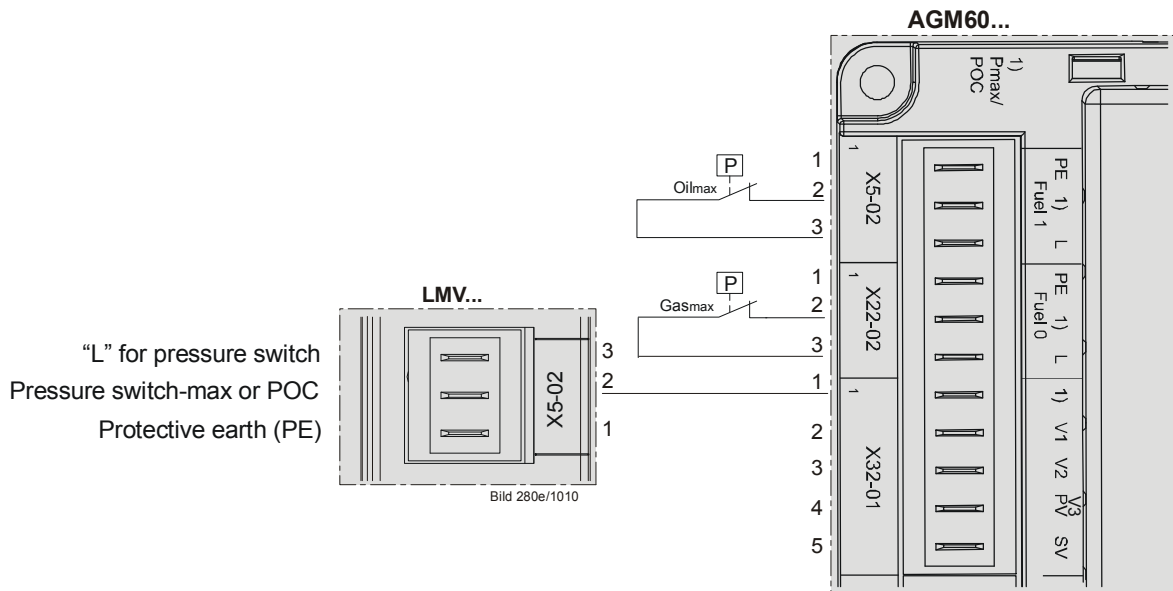

Figure 30: LMV36 with AGM60: Gas / oil pressure switch-max or POC X5-02

The connection facility can also be used as POC (proof of closure) (refer to chapter *Sequence diagrams*).

No.	Parameter
237	Gas: Input pressure switch-max / POC 1 = pressure switch-max 2 = POC 3 = pressure switch valve proving 4 = additional speed-dependent air pressure switch
337	Fuel 1 gas: Input pressure switch-max / POC 1 = pressure switch-max 2 = POC 3 = pressure switch valve proving 4 = additional speed-dependent air pressure switch



Note

If the input is used for POC or for pressure switch, pressure-switch-max can be included in the safety loop. In that case, pressure switch-max must not be fitted between the valves, but downstream from them.

Gas pressure switch-max

In all types of gas trains, the maximum gas pressure is monitored from phase 40. If the maximum gas pressure is exceeded, the system initiates lockout.

Error code	Diagnostic code	Meaning for the LMV36
14	0	POC open
	1	POC closed
21	0	Pressure switch-max: Max. gas pressure exceeded POC: POC open (software version ≤V02.00)
	1	POC closed (software version ≤V02.00)

During the safety times, the signal from pressure switch-max is only assessed after a certain period time has elapsed in order to ignore the pressure shocks that occur the moment the valves open.

No.	Parameter
229	Gas: Time to respond to pressure faults in the first and second safety time
329	Fuel 1 gas: Time to respond to pressure faults in the first and second safety time

Pressure switch-max-oil

In all types of oil trains, the maximum oil pressure is monitored from phase 22. If the maximum oil pressure is exceeded after the maximum time (parameter 214) has elapsed, or during the subsequent phases, the system initiates lockout.

No.	Parameter
214	Maximum time to start release

Error code	Diagnostic code	Meaning for the LMV36
14	0	POC open
	1	POC closed
21	0	Pressure switch-max: Max. oil pressure exceeded POC: POC open (software version \leq V02.00)
	1	POC closed (software version \leq V02.00)

During the safety times, the signal from pressure switch-max is only assessed after a certain period of time has elapsed to ignore the pressure shocks that occur the moment the valves open.

No.	Parameter
269	Oil: Time to respond to pressure faults in the first and second safety time
369	Fuel 1 oil: Time to respond to pressure faults in the first and second safety time

The pressure switch connection can also be used as POC (Proof of Closure) (refer to chapter *Sequence diagrams*).

No.	Parameter
277	Oil: Input pressure switch-max / POC
	1 = pressure switch-max
	2 = POC
	3 = not used
377	Fuel 1 oil: Input pressure switch-max / POC
	1 = pressure switch-max
	2 = POC
	3 = not used
	4 = additional speed-dependent air pressure switch



Note

If the input is used for POC, pressure switch-max can be included in the safety loop. In that case, pressure switch-max must not be fitted between the valves, but after them.

Start release oil

If the input is simultaneously used as a start release input (e.g. for an air supply damper), the latter can be connected in series with the pressure switch.

If the input is parameterized for POC, it cannot be used as a start release input.

Additional speed-dependent air pressure switch

In this setting, an additional speed-dependent air pressure switch can be connected on the input.

The input is evaluated depending on the actual recorded speed. The actual speed must be identified through a speed recording process (see Chapter 13.7 Acquisition of speed).

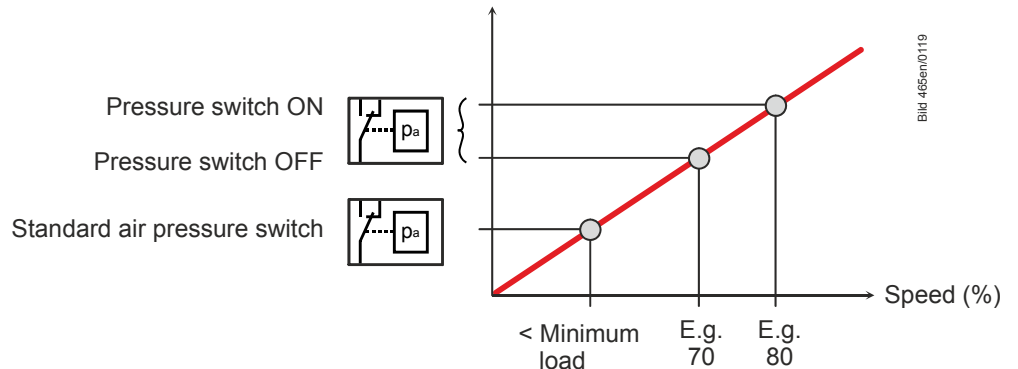

Figure 31: Additional speed-dependent air pressure switch

No.	Parameter
670	Speed air pressure switch OFF
671	Speed air pressure switch ON

The parameters 670 and 671 specify the speed limit of the VSD, from which the connected additional air pressure switch is supervised. If the current speed is higher than the ON threshold, the air pressure switch must deliver an ON signal. If the current speed is lower than the OFF threshold, the air pressure switch must deliver an OFF signal.

If the current speed is between the two speed limits, no evaluation of the air pressure switch takes place. The input is supervised in the phases from prepurging to postpurging and the valve proving phases. An incorrect signal leads to a shutdown. Intermittent operation must be activated (OEM level) if the speed-dependent air pressure switch is used as a plausibility check (resulting air pressure) for the symmetrical speed signal of a PWM fan.



Note!

If the input is configured to additional speed-dependent air pressure switches and the VSD is deactivated, no evaluation of the air pressure switch signal takes place.

Error code	Diagnostic code	Meaning for the LMV36
18	0	Speed-dependent air pressure switch open
	1	Speed-dependent air pressure switch closed
	128	Invalid parameterization of the speed thresholds (speed air pressure switch OFF \geq speed air pressure switch ON)

7.3.10 Fuel selection

The fuel selection is made by an external connected switch at AGM60.

The selection made is transmitted to the LMV36 via 2 signal lines (internal fuel selection 0 + 1).

Fuel 0 = 1, Fuel 1 = 0 → Fuel 0 is selected

Fuel 0 = 0, Fuel 1 = 1 → Fuel 1 is selected

Fuel 0 = 0, Fuel 1 = 0 → Line interrupted

→ Safety shutdown / lockout

Fuel 0 = 1, Fuel 1 = 1 → Invalid fuel selection → Safety shutdown / lockout

Next time the burner is started up after shutdown or safety shutdown, the **new** fuel is used.

After a change in fuel, any manual operation output or output specification from a building automation and control system is deleted and automatic mode is activated so that an automatic restart can take place with the new fuel if a heat request is present.

Exception:

The manual off function for manual output and burner off (output = 0) via the building automation system are maintained.

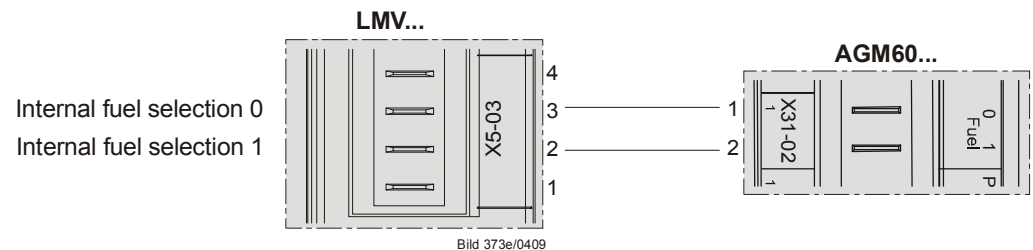

Figure 32: LMV36 with AGM60: Fuel selection

7.3.11 Reset X8-04, pin 1

Input for connection of a reset button. The LMV36 can be reset or manually locked via this input (refer to chapter *Reset / manual locking*).

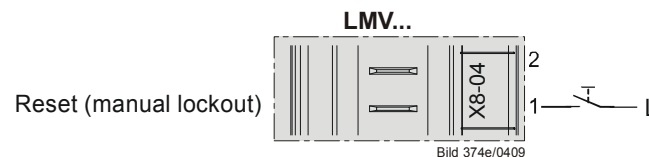

Figure 33: Reset X8-04

7.4 Digital outputs

Safety-related outputs, type SI

Using a contact feedback network, these contacts are read back by the microcomputers and checked for their correct positions.

Non-safety-related outputs, type No-SI

These outputs are not monitored by the contact feedback network and, for this reason, can only be used for non-safety-related actuators, or actuators made safe in some other form (e.g. alarm).

7.4.1 Output alarm type No-SI X3-05 pin 2

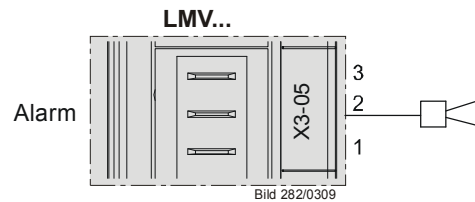

Figure 34: Output alarm X3-05

Output for connection of an alarm lamp or horn.

The output is activated when the LMV36 is in the lockout position (phase 00). This output can also be used to indicate start prevention.

7.4.2 Fan motor contactor type SI X3-05, pin 1

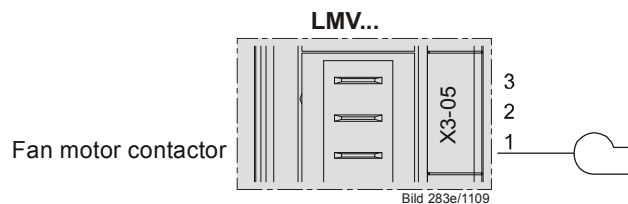

Figure 35: Fan motor contactor X3-05

Output for control of a fan power contactor (200 VA). In accordance with the sequence diagrams, the fan is on in phase 22 (refer to chapter *Sequence diagrams*).

7.4.3 Fan continuous purging X3-05, pin 3

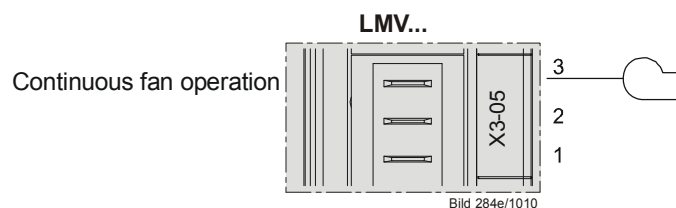

Figure 36: Continuous fan operation X3-05

If continuous purging is required, the fan motor contactor must be connected to *Continuous fan operation – X3-05*, pin 3. This terminal is tapped behind the unit fuse and the safety loop (refer to chapter *Continuous fan*).

7.4.4 Output ignition type SI (IGNITION) X4-02

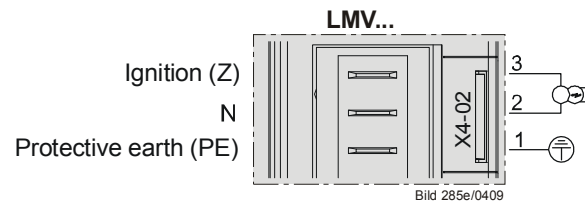

Figure 37: Output ignition X4-02

Output for the connection of ignition transformers or electronic ignition modules.

Gas

When firing on gas, ignition is switched on just prior to the first safety time in phase 38.

The preignition time in phase 38 can be parameterized.

No.	Parameter
226	Gas: Preignition time
326	Fuel 1 gas: Preignition time

Oil

When firing on oil, there is a choice between long and short preignition (as with gas operation from phase 38).

No.	Parameter
281	Oil: Point in time oil is ignited 0 = short preignition (phase 38) 1 = long preignition (with fan) (phase 22)
381	Fuel 1 oil: Point in time oil is ignited 0 = short preignition (phase 38) 1 = long preignition (with fan) (phase 22)

When using long preignition, ignition is switched on in phase 22, together with the fan.

In the case of short preignition, the preignition time can be parameterized.

No.	Parameter
266	Oil: Preignition time
366	Fuel 1 oil: Preignition time

7.4.5 Outputs fuel valves type SI V1 / V2 / V3 / PV X8-02, X7-01, X7-02

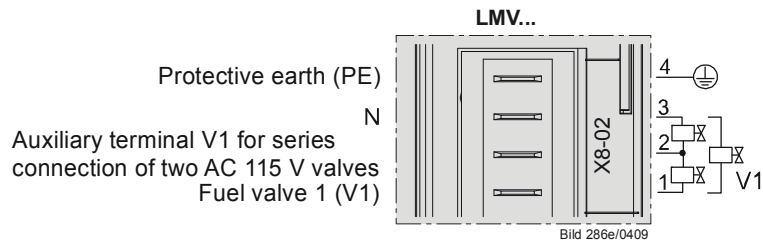

Figure 38: LMV36: Output fuel valve V1 X8-02

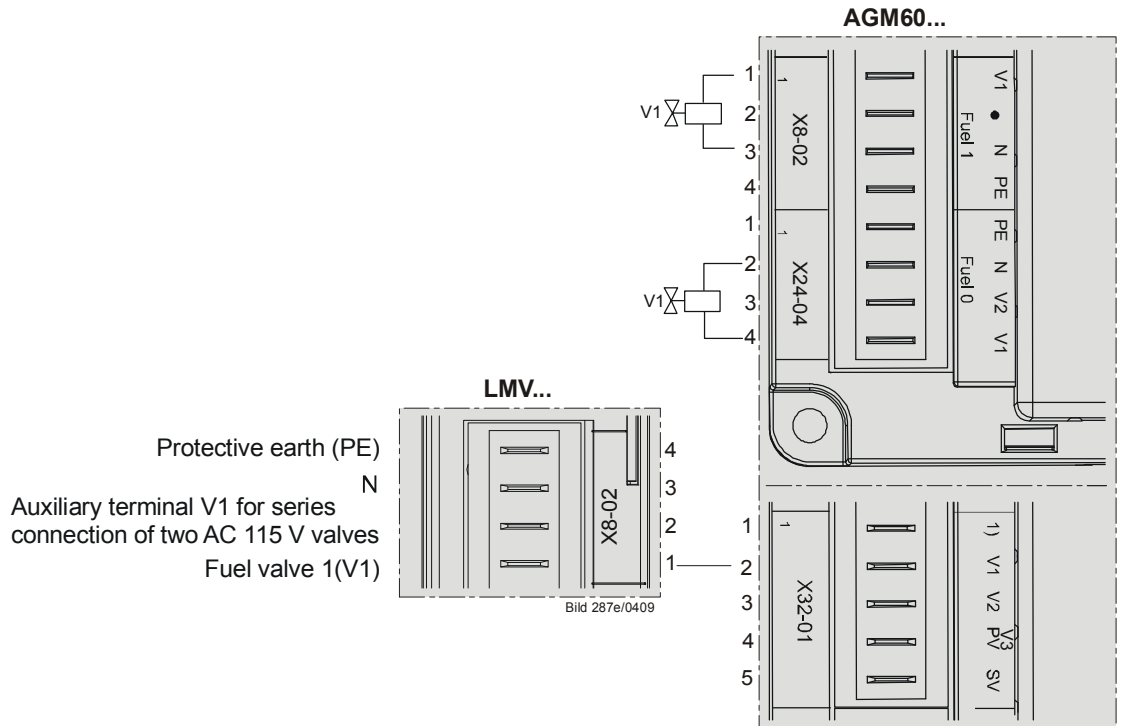

Figure 39: LMV36 with AGM60: Output fuel valve V1 X8-02

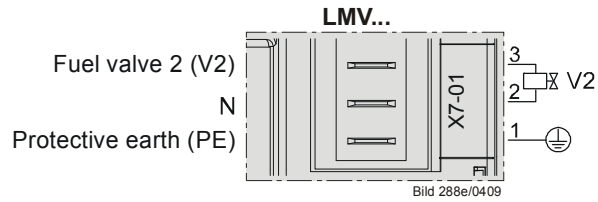

Figure 40: LMV36: Output fuel valve V2 X7-01

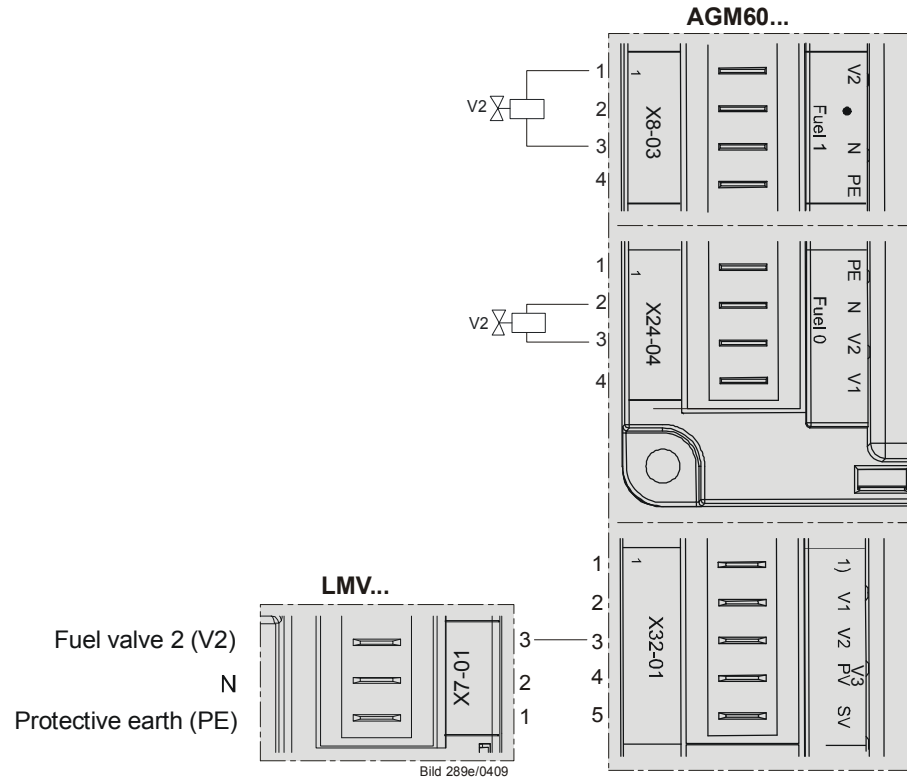

Figure 41: LMV36 with AGM60: Output fuel valve V2 X7-01

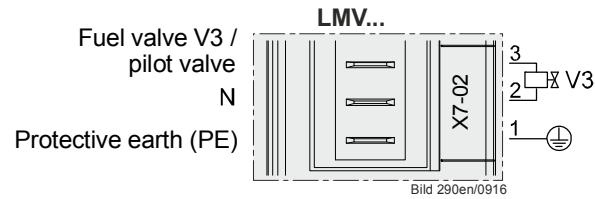

Figure 42: LMV36: Output fuel valve V3 / pilot valve X7-02

Outputs for connection of the gas or oil valves, depending on the selected type of fuel train (refer to chapter *Sequence diagrams*).

7.4.6 Output safety valve type SI X6-03 / magnetic clutch

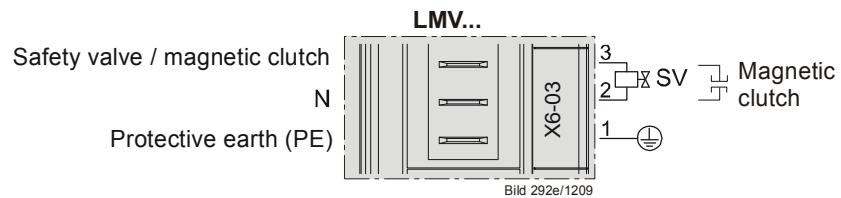

Figure 43: LMV36: Output safety valve / magnetic clutch X6-03

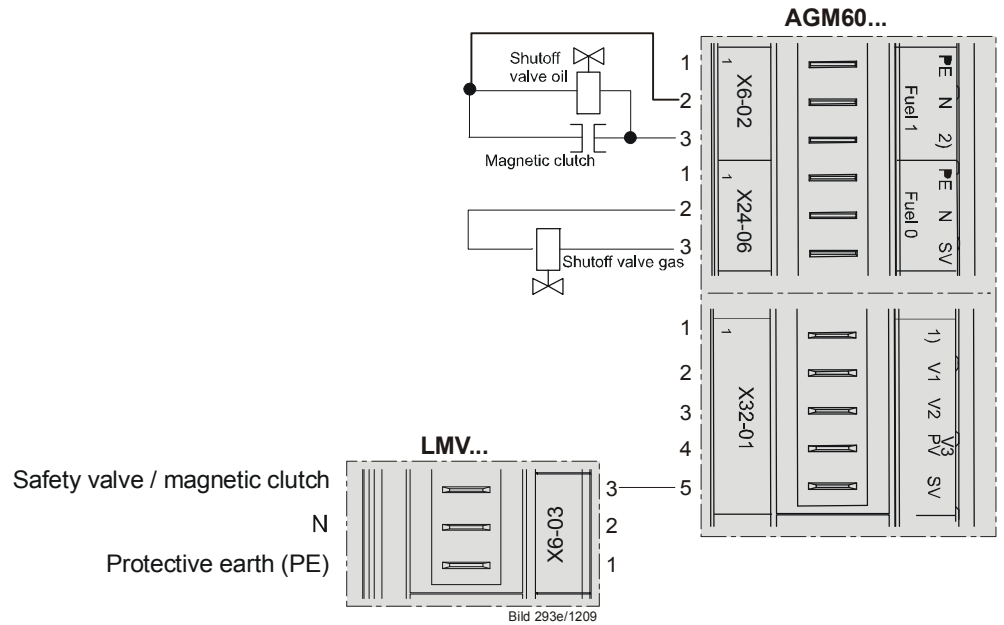

Figure 44: LMV36 with AGM60: Output safety valve / magnetic clutch X6-03

Output for connection of an oil shutoff valve / oil connection valve or safety valve for liquefied gas. The output is connected parallel to the output for the fan.

7.4.7 Output for indication of operation X8-04 pin 2

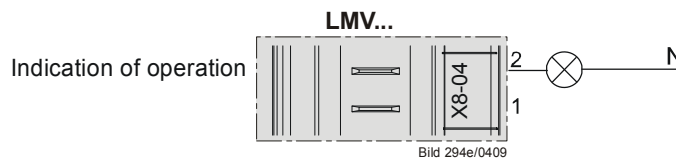

Figure 45: Output for indication of operation X8-04

Output for connection of indication of operation.



Caution!
The output is connected parallel to the fuel valve V1.

7.5 Program sequence

The program sequence is shown in the form of sequence diagrams (refer to chapter *Fuel trains application examples*). Using a number of parameters, the program sequence can be adapted to the respective application.

7.5.1 Time parameters

Using a number of time parameters, the time characteristics of the different types of fuel trains can be matched to the requirements of the respective application.

In single-fuel operation or in dual-fuel operation, the parameters 225...299 are assigned to fuel 0.

No.	Parameter
211	Fan rump-up time
212	Maximum time to low-fire
213	Waiting time home run
214	Maximum time to start release
217	Max. Waiting time for detection of detector or pressure signal (e.g. homerun, preignition «Lo»)
225	Gas: Prepurge time
226	Gas: Preignition time
227	Gas: First safety time
229	Gas: Time to respond to pressure faults in the first and second safety time
230	Gas: Interval 1
231	Gas: Second safety time
232	Gas: Interval 2
233	Gas: Afterburn time
234	Gas: Postpurge time (no extraneous light test)
242	Gas: Valve proving - test space evacuating
243	Gas: Valve proving - test time atmospheric pressure
244	Gas: Valve proving - test space filling
245	Gas: Valve proving - test time gas pressure
246	Gas: Waiting time gas shortage
248	Gas: Postpurge time (abortion if load controller ON)
265	Oil: Prepurge time
266	Oil: Preignition time
267	Oil: First safety time
269	Oil: Time to respond to pressure faults in the first and second safety time
270	Oil: Interval 1
271	Oil: Second safety time
272	Oil: Interval 2
273	Oil: Afterburn time
274	Oil: Postpurge time (no extraneous light test)
284	Oil: Postpurge time (abortion if load controller ON)

In dual-fuel operation, the parameters 325...399 are assigned to fuel 1.

No.	Parameter
325	Fuel 1 gas: Prepurge time
326	Fuel 1 gas: Preignition time
327	Fuel 1 gas: First safety time
329	Fuel 1 gas: Time to respond to pressure faults in the first and second safety time
330	Fuel 1 gas: Interval 1
331	Fuel 1 gas: Second safety time
332	Fuel 1 gas: Interval 2
333	Fuel 1 gas: Afterburn time
334	Fuel 1 gas: Postpurge time (no extraneous light test)
342	Fuel 1 gas: Valve proving - test space evacuating
343	Fuel 1 gas: Valve proving - test time atmospheric pressure
344	Fuel 1 gas: Valve proving - test space filling
345	Fuel 1 gas: Valve proving - test time gas pressure
346	Fuel 1 gas: Waiting time gas shortage
348	Fuel 1 gas: Postpurge time (abortion if load controller On)
365	Fuel 1 oil: Prepurge time
366	Fuel 1 oil: Preignition time
367	Fuel 1 oil: First safety time
369	Fuel 1 oil: Time to respond to pressure faults in the first and second safety time
370	Fuel 1 oil: Interval 1
371	Fuel 1 oil: Second safety time
372	Fuel 1 oil: Interval 2
373	Fuel 1 oil: Afterburn time
374	Fuel 1 oil: Postpurge time (no extraneous light test)
384	Fuel 1 oil: Postpurge time (abortion if load controller On)



Caution!

The OEM or the heating engineer must make certain that the times conform to the standards covering the respective type of plant.

7.5.2 Valve proving

Valve proving is active only when firing on gas. Valve proving designed to detect leaking gas valves and, if necessary, to prevent the valves from opening or ignition from being switched on. Lockout is initiated, if required.

When making the valve proving test, the gas valve on the burner side is opened first to bring the test space to atmospheric pressure. When the valve is closed, the pressure in the test space is not allowed to exceed a certain level. Then, the test space is pressurized by opening the gas valve on the mains side. After closing, the gas pressure must not fall below a certain level.

Valve proving can be parameterized to take place on startup, shutdown, or both. Type of valve proving can be selected via parameter 236 / 336 or 237 / 337.

Recommendation:

Perform valve proving on shutdown.

No.	Parameter
236	Gas: Input pressure switch-min 1 = pressure switch-min before fuel valve V1 (default setting) 2 = valve proving via pressure switch-min (between fuel valve V1 and fuel valve V2) 3 = pressure switch-min after fuel valve V2
237	Gas: Input pressure switch-max / POC 1 = pressure switch-max 2 = POC 3 = pressure switch valve proving 4 = additional speed-dependent air pressure switch
241	Gas: Execution-valve proving 0 = no valve proving 1 = valve proving on startup 2 = valve proving on shutdown 3 = valve proving on startup and shutdown
242	Gas: Valve proving - test space evacuating
243	Gas: Valve proving - test time atmospheric pressure
244	Gas: Valve proving - test space filling
245	Gas: Valve proving - test time gas pressure
336	Fuel 1 gas: Input pressure switch-min 1 = pressure switch-min before fuel valve V1 (default setting) 2 = valve proving via pressure switch-min (between fuel valve V1 and fuel valve V2) 3 = pressure switch-min after fuel valve V2
337	Gas: Input pressure switch-max / POC 1 = pressure switch-max 2 = POC 3 = pressure switch valve proving 4 = additional speed-dependent air pressure switch
341	Fuel 1 gas: Execution-valve proving 0 = no valve proving 1 = valve proving on startup 2 = valve proving on shutdown 3 = valve proving on startup and shutdown
342	Fuel 1 gas: Valve proving - test space evacuating
343	Fuel 1 gas: Valve proving - test time atmospheric pressure
344	Fuel 1 gas: Valve proving - test space filling
345	Fuel 1 gas: Valve proving - test time gas pressure



Caution!

If valve proving is parameterized to take place on startup and shutdown, the gas valves must run through additional switching cycles. As a result, strain on the gas valves (wear) increases.



Caution!
The OEM must set the evacuation, filling and test times for atmospheric or mains pressure on every plant in compliance with the requirements of EN 1643.

It must be ensured that the 2 test times are correctly set. It is to be checked whether the gas required for the test may be fed into the combustion chamber (on the relevant application). The test times are safety-related. After a reset and in the case of aborted or prevented valve proving, the unit performs valve proving on the next startup (only when valve proving is activated). Prepurging with valve proving is active during the startup phase, even if it was deactivated.

Examples of aborted valve proving:

If the safety loop or the start prevention input for gas (containing pressure switch-min) opens during valve proving.

Valve proving – calculation of leakage rate

$$t_{\text{Test}} = \frac{(P_G - P_W) \cdot V \cdot 3600}{P_{\text{atm}} \cdot Q_{\text{Leck}}}$$

QLeck	in l/h	Leakage rate in liters per hour
PG	in mbar	Overpressure between the valves at the beginning of the test phase
PW	in mbar	Overpressure set on the pressure switch (normally 50% of the gas inlet pressure)
Patm	in mbar	Absolute air pressure (1013 mbar normal pressure)
V	in l	Volume between the valves (test volume) including valve volume and pilot pipe, if present (Gp1 mod)
tTest	in s	Test time

7.5.3 Valve proving with separate pressure switch X9-04

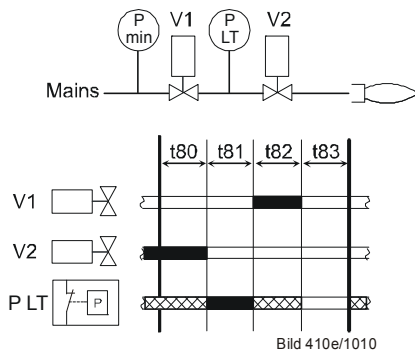

Figure 46: Valve proving with separate pressure switch

Step 1: t80 – evacuation of test space.

Gas valve on the burner side is opened to bring the test space to atmospheric pressure.

Step 2: t81 – test time atmospheric pressure.

When the gas valve has closed, the gas pressure in the test space must not exceed a certain level.

Step 3: t82 – filling of test space.

Gas valve on the mains side opens to fill the test space.

Step 4: t83 – test time gas pressure.

When the gas valve has closed, the gas pressure in the test space must not drop below a certain level.

Legend

t80	Evacuation of test space (parameter 242)
t81	Test time atmospheric pressure (parameter 243)
t82	Filling of test space (parameter 244)
t83	Test time gas pressure (parameter 245)
Vx	Fuel valve
P LT	Pressure switch – valve proving
Pmin	Pressure switch-min
	Input/output signal 1 (ON)
	Input/output signal 0 (OFF)
	Input permissible signal 1 (ON) or 0 (OFF)

7.5.4 Valve proving via gas pressure switch-min X5-01

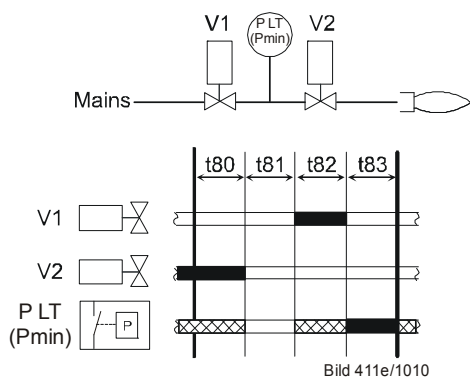

Figure 47: Valve proving via gas pressure switch-min

Step 1: t80 – evacuation of test space.

Gas valve on the burner side is opened to bring the test space to atmospheric pressure.

Step 2: t81 – test time atmospheric pressure.

When the gas has closed, the gas pressure in the test space must not exceed a certain level.

Step 3: t82 – filling of test space.

Gas valve on the mains side opens to fill the test space.

Step 4: t83 – test time gas pressure.

When the gas valve has closed, the gas pressure in the test space must not drop below a certain level.

Legend

t80	Evacuation of test space (parameter 242)
t81	Test time atmospheric pressure (parameter 243)
t82	Filling of test space (parameter 244)
t83	Test time gas pressure (parameter 245)
Vx	Fuel valve
Pmin	Pressure switch-min
P LT	Pressure switch – valve proving
	Input/output signal 1 (ON)
	Input/output signal 0 (OFF)
	Input permissible signal 1 (ON) or 0 (OFF)

Performing valve proving via gas pressure switch-min affects the program sequence as follows (see Addendum *Sequence diagram «G»*):

- a) Valve proving on startup:
Gas pressure switch-min (gas shortage test) is not sampled in phase 22, but during valve proving at the end of the filling time.
- b) Valve proving on shutdown / deactivated:
Gas pressure switch-min is sampled after preignition. For that purpose, a new phase 39 (pressure switch-min test) is introduced and, at the end of the phase (duration of phase = filling time). In practice, this represents an *extension* of preignition by the filling time, if valve proving via gas pressure switch-min was selected.

Valve proving test can only be made via the gas pressure switch-min.

The pressure switch must be fitted between the valves.

This has an impact on the program sequence (refer to chapter *Sequence diagrams*).

Valve proving continues to be activated via parameters 241 and 341.

No.	Parameter
241	Gas: Execution valve proving 0 = no valve proving 1 = valve proving on startup 2 = valve proving on shutdown 3 = valve proving on startup and shutdown
341	Fuel 1 gas: Execution valve proving 0 = no valve proving 1 = valve proving on startup 2 = valve proving on shutdown 3 = valve proving on startup and shutdown

7.5.4.1. Lockout phase (phase 00)

The relays of the fuel valves and the safety relay (fan) are deenergized, the alarm relay is energized and lockout takes place. This means that phase 00 can only be quit via a manual reset. The time of phase 00 is unlimited.

7.5.4.2. Safety phase (phase 02)

The safety phase is an intermediate phase which is completed prior to triggering lockout. The relays of the fuel valves and the safety relay (fan) are deenergized, but lockout does not yet take place. The alarm relay is not yet activated. If possible or permitted, safety checks or repetition counter checks are made whose results decide on the transition to *Lockout phase* or *Standby*. The duration of the safety phase is dynamic (depending on the extent of testing), the maximum time being 30 seconds. This process is aimed primarily at avoiding unwanted lockouts, e.g. resulting from EMC problems.

7.5.5 Special functions during the program sequence

7.5.5.1. Reset / manual lockout

The LMV36 can be manually locked by simultaneously pressing the **Info** button and **any other button** on the AZL2. This function enables the user to interlock the LMV36 from any operating level, that is, to trigger unalterable shutdown. Due to the system's makeup, this facility does not constitute an *Emergency OFF* function.

When making a reset, the following actions are carried out:

- Alarm relay and fault display are switched off
- The lockout position is cancelled
- The LMV36 makes a reset and then changes to standby

There are 3 choices to reset the LMV36.

1. Reset on the AZL2

If the LMV36 is in the lockout position, a reset can be made by pressing the **Info** button for 1...3 seconds. The function is available only when the LMV36 is in the lockout position. Longer or shorter pushes on the button do not produce a reset so that the system maintains the lockout position.

Error code	Diagnostic code	Meaning for the LMV36
167	2	Manual lockout by the AZL2

2. Resetting by pressing the button by the *Reset* connection terminal on the LMV36 (X8-04, pin 1)

If the unit is in the lockout position, a reset can be made by pressing the button for 1...3 seconds. Longer or shorter pushes on the button are ignored so that the LMV36 maintains the lockout position. If the unit is **not** in the lockout position and the reset button is pressed for 1...6 seconds, a change to the lockout position takes place. If this response is not desirable, it is possible to tap the supply for the reset button from the alarm output, thus achieving the same response as described above under 1.

Error code	Diagnostic code	Meaning for the LMV36
167	1	Manual lockout by contact

Reset without manual lockout

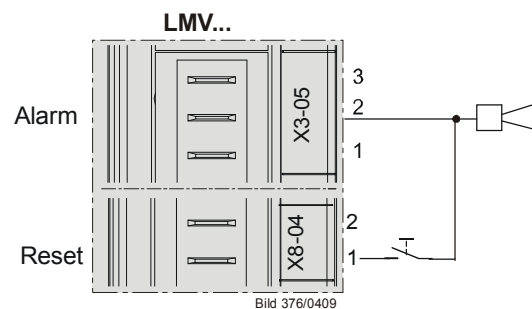

Figure 48: Without manual lockout

Reset with manual lockout

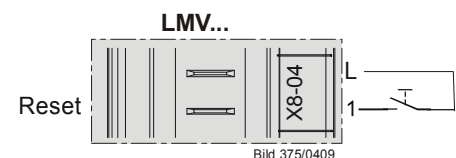

Figure 49: With manual lockout

3. Resetting via the PC software ACS410

Refer to the documentation covering the PC software ACS410 (J7352).

Error code	Diagnostic code	Meaning for the LMV36
167	3	Manual lockout by PC software ACS410

7.5.5.2. Alarm upon prevention of startup

If start prevention occurs, it is shown on the display of the AZL2. Start prevention takes place only when a heat request is delivered **and** when one of the startup criteria is not fulfilled. The time to elapse from prevention of startup to display on the AZL2 is set to a fixed value of 5 seconds. In addition, it is possible to indicate preventions of startup via the alarm output. This function can be activated per parameter.

No.	Parameter
210	Alarm in the event of start prevention 0 = deactivated 1 = activated

If *Alarm in the event of start prevention* is activated via the alarm relay, prevention of startup and lockout can only be distinguished via the display on the AZL2. Preventions of startup are displayed as **Err:**, lockouts as **Loc:**.



Note

If the reset contact X8-04 Pin 1 on the LMV36 is activated during a startup prevention, the LMV36 will be manually locked. The time from occurrence of prevention of startup to indication by the alarm contact equals the time to the display on the AZL2.

7.5.5.3. Possible preventions of startup

On the normal display, error code 201 is translated to text display **OFF UPr0** or **OFF UPr1** (UPr = unprogrammiert = not programmed); the numerical value appears in the error history.

Error code	Diagnostic code	Meaning for the LMV36
201 OFF UPr0 or OFF UPr1	1	No operating mode selected
	2...3	No fuel train defined
	4...7	No curve defined
	8...15	Standardized speed undefined
	16...31	Backup / restore was not possible
		Other preventions of startup:
3	4	Air pressure on – prevention of startup
4	2	Extraneous light during startup – prevention of startup
14	64	POC open- prevention of startup
21	64	POC open – prevention of startup (software version ≤V02.00)
22 OFF S	1	Safety loop / burner flange open- prevention of startup
83	#	Speed error VSD
97	#	Error relay supervision
	0	Safety relay contacts have welded or external power supply fed to safety relay

No.	Parameter
642	Standardized speed Index 0 = speed 1 Index 1 = speed 2 (internal monitoring) Fuel 1: Index 2 = fuel 1: Speed 1 Index 3 = fuel 1: Speed 2 (internal monitoring)
935	Absolute speed
936	Standardized speed

7.5.5.4. Repetition counter

Repetition counters are available for different types of errors. They are used to set the number of errors permitted until lockout occurs. The last error initiates lockout. When setting the number of errors to 3, for example, a repetition (restart) takes place after the first 2 errors, and after the third error, the LMV36 initiates lockout.



Note

Setting 16 means an infinite number of repetitions = no lockout.

Functions with adjustable repetition counter

No.	Parameter
194	Repetition limit no flame at the end of safety time 1 = no repetition 2...4 = 1...3 repetitions Recharging time: Entering into operation
196	Repetition limit air pressure failure 1 = no repetition 2 = 1 repetition 3 = 2 repetitions Recharging time: End of <i>Shutdown</i> phase / 24 hours continuous operation
199	Repetitions limit value - actuators 1 = no repetition 2 = 1 repetition 3 = 2 repetitions
215	Repetition limit safety loop 1 = no repetition 2...15 = 1...14 number of repetitions 16 = constant repetition Recharging time: Every 24 hours
223 323	Repetition limit value gas pressure switch-min 1 = no repetition 2...15 = 1...14 number of repetitions 16 = constant repetition Recharging time: After the <i>Operation</i> phase
240 340 280 380	Repetition limit value loss of flame 1 = no repetition 2 = 1 repetition Recharging time: After the <i>Operation</i> phase

Error code	Diagnostic code	Meaning for the LMV36
2	1	No flame at the end of the first safety time
3	0	Air pressure
7	0	Loss of flame
20	0	Pressure switch-min No minimum gas / oil pressure
22 OFF S	0	Safety loop / burner flange open
82	#	Error during VSD's speed standardization
83	#	Speed error VSD
85	#	Referencing error ones actuators
86	#	Error fuel actuator
87	#	Error air actuator

If the adjustable repetition counter limits are changed, the actual counter is recharged only when the associated recharging time is reached: After power-on or after a reset.



Note

If immediate recharging shall be enforced, the LMV36 can be manually locked and then reset.

Functions with fixed repetition counters

These counters cannot be set.

Meaning	Settings
	Basic setting
Number of repetitions in the event of error: <ul style="list-style-type: none"> Relay Relay control Recharging time: End of <i>Operation</i> phase	2
Number of repetition in the event of internal error Recharging time: After 24 hours of operation	5

Error code	Diagnostic code	Meaning
95...98	#	Error relay supervision
99...100	#	Internal error relay control

7.5.5.5. Start without prepurging (as per EN 676)

When using valve proving and 2 fuel valves of class A, prepurging is not required (conforming to EN 676).

Prepurging can be deactivated via parameter.

No.	Parameter
222	Gas: Prepurging 0 = inactive 1 = active
322	Fuel 1 gas: Prepurging 0 = inactive 1 = active

When prepurging is activated, it is performed in accordance with the adjusted prepurge time.

If not activated, it is nevertheless performed if the following conditions apply:

- Alterable lockout position
- After an off time of >24 hours
- In the event of a power failure (power-on)
- In the event of shutdown due to an interruption of gas supply (safety shutdown)

No.	Parameter
225	Gas: Prepurge time
325	Fuel 1 gas: Prepurge time

7.5.5.6. Gas shortage program

Valve proving via gas pressure switch-min (parameter 236 = 2)

Since gas pressure switch-min is not located between the fuel valves, the gas shortage test cannot be made in phase 22. Therefore, when performing valve proving on startup, the gas shortage test is made at the end of the filling time (end of phase 82).

With no valve proving on startup, the gas shortage test is made directly before first safety time is started (end of phase 39).

No.	Parameter
236	Gas: Input pressure switch-min 2 = valve proving via pressure switch-min (between fuel valve V1 and fuel valve V2)

Standard valve proving (parameter 236 = 1)

If the gas pressure is too low, startup is aborted in phase 22.

No.	Parameter
236	Gas: Input pressure switch-min 1 = pressure switch-min before fuel valve V1 (default setting)
246	Gas: Waiting time gas shortage
346	Fuel 1 gas: Waiting time gas shortage

If gas shortage occurs with the last of the parameterized number of start attempts, the system initiates lockout.

No.	Parameter
223 323	Repetition limit value gas pressure switch-min 1 = no repetition 2...15 = 1...14 number of repetitions 16 = constant repetition Recharging time: After the <i>Operation</i> phase

In that case, the LMV36 makes with gas shortage program a selectable number of start attempts until lockout occurs. The waiting time from one start attempt to the next is doubled each time, starting from an adjustable waiting time.

7.5.5.7. Program stop function

To simplify the burner settings in connection with commissioning and service work, the program sequence of the LMV36 can be stopped at the following positions:

- 1) Air damper in prepurge position 24
- 2) Ignition position 36
- 3) Interval 1 44
- 4) Interval 2 52

The program stops are integrated in the setting sequence when the plant is commissioned (refer to chapter *Air-fuel ratio curves – settings and commissioning*). After the initial settings, program stops can be activated on the parameter level.

No.	Parameter
208	Program stop 0 = deactivated 1 = prepurge position (phase 24) 2 = ignition position (phase 36) 3 = interval 1 (phase 44) 4 = interval 2 (phase 52)

The program stop function is maintained until manually deactivated. If the LMV36 halts at one of the program stops, a message appears on the display of the AZL2.

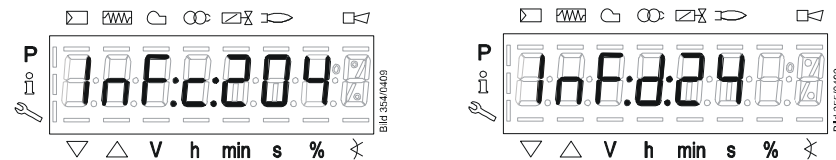

Figure 50: Message in the case of program stop

Example: **c:204** alternating with **d:24** corresponding to program stop in prepurge position.

7.5.5.8. Forced intermittent operation (<24 hours)

When forced intermittent operation is activated, the unit shuts down for a moment after 23 hours and 45 minutes of uninterrupted operation, shutdown and followed by an automatic restart.

Forced intermittent operation is a standard feature.

No.	Parameter
239	Gas: Forced intermittent operation 0 = inactive 1 = active
279	Oil: Forced intermittent operation 0 = inactive 1 = active
339	Fuel 1 gas: Forced intermittent operation 0 = inactive 1 = active
379	Fuel 1 oil: Forced intermittent operation 0 = inactive 1 = active

7.5.5.9. Low-fire shutdown

To prevent the boiler from being shut down under full or nearly full load conditions, electronic air-fuel ratio control can run the burner to the low-fire position first when there is no more request for heat (refer to chapter *End of operating position*).

7.5.5.10. Continuous fan

With burners that can be damaged by heat (e.g. several burners using the same combustion chamber), continuous purging may be required. In that case, the fan operates continuously in all phases.

For that purpose, the fan motor contactor is to be connected to X3-05, pin 3, tapped after the unit fuse and the safety loop.

For checking the air pressure switch, a pressure switch relief valve must be connected to fan output X3-05, pin 1. When output X3-05, pin 1, is activated, the relief valve diverts the fan pressure to the air pressure switch and, when deactivated, ensures that no pressure is fed to the switch.

Example:

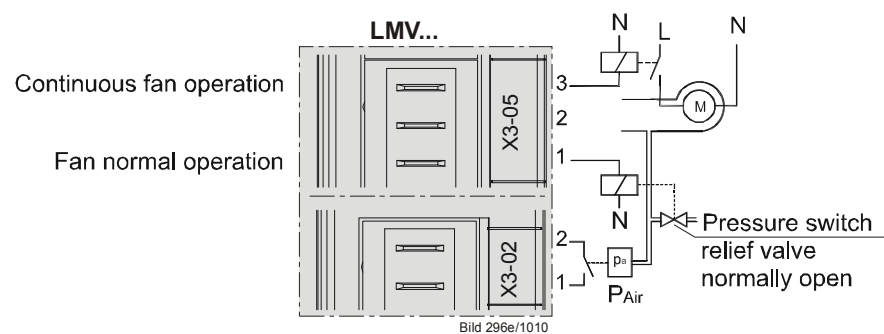

Figure 51: Continuous fan

7.5.5.11. Test function for burner approval – loss-of-flame test (TÜV test)

The purpose of this test is to verify the detection time required in the event of loss of flame when applying for burner approval. When starting the test, the fuel valves are shut to determine the time (resolution of 0.2 seconds) until the LMV36 detects loss of flame.

Procedure:

- Determine the burner output at which the test shall be made, using parameter 133 (fuel 0) or parameter 134 (fuel 1). If these parameters are not set, the test is carried out at the current output of the system
- Start the test by entering the value of 1 for parameter 124.
If the burner's output for the test is set (parameter 133 or 134), the LMV36 is driven to that output level first. To ensure this function, the presetting of parameter 121 (manual output) is used. This cancels any manual output that was previously active
- Now, the LMV36 shuts the fuel valves, leading to loss of flame
- The evaluation is made by the LMV36 by measuring the time the system requires from fuel valve shutdown until loss of flame is detected.
Then, the measured value is available as a diagnostic code in connection with error **C:7** (loss of flame)

The resolution is 0.2 seconds.

Example:

The display of **C:7 D:10** means that the time required from valve shutdown to detection of loss of flame is 2 seconds (**D:10** corresponding 10 x 0.2 seconds).

When the test is successfully completed, parameter 124 is reset to **0**. If unsuccessful, a negative value is delivered for diagnostic purposes and error code 150 is entered.

- 1 = invalid phase (test possible in phase 60 only) – message displayed: **C:150 D:1**
- 2 = default output < minimum output – message displayed: **C:150 D:2**
- 3 = default output > maximum output – message displayed: **C:150 D:3**
- 4 = manual abortion (no error, start variable was manually reset to **0**) – message displayed: **C:150 D:4**
- 5 = timeout with TÜV test (no loss of flame within 50 seconds after valves were shut) – lockout: **C:150 D:5**

Values previously set for the burner's output at which the test shall be made (parameter 133 or 134) remain stored.

No.	Parameter
121	Manual output Undefined = automatic operation
124	Loss of flame test (TÜV test) starting (parameterized on 1) (switch off the fuel valves → loss of flame) Error diagnostic via negative value (refer to error code 150)
133	Default output at TÜV test Invalid = TÜV test at active output 20...100 = low-fire...high-fire or stage 1 / stage 2 / stage 3 P1...P3 = stage 1...stage 3
134	Fuel 1: Default output at TÜV test Invalid = TÜV test at active output 20...100 = low-fire...high-fire or stage 1 / stage 2 / stage 3 P1...P3 = stage 1...stage 3

7.5.5.12. Postpurging in the lockout position

Parameter 190 can be used to move the actuators (actuators or VSD) to the postpurge position while they are in the lockout position.

No.	Parameter
190	Postpurging in lockout position 0 = deactivate (no-load position) 1 = active (postpurge position) When active, the <i>Alarm in the event of start prevention</i> function (parameter 210) is only possible to a limited extent!



Note!

The LMV36 simply moves the actuators (actuators or VSD) to the postpurge position. A fan or VSD release contact cannot be controlled, as the alarm relay of the LMV36 cuts off the power supply to the outputs. With the *Alarm in the event of start prevention* function, an external circuit that may be present for controlling the fan / VSD release contact for postpurging in the lockout position is activated via start prevention in standby mode.

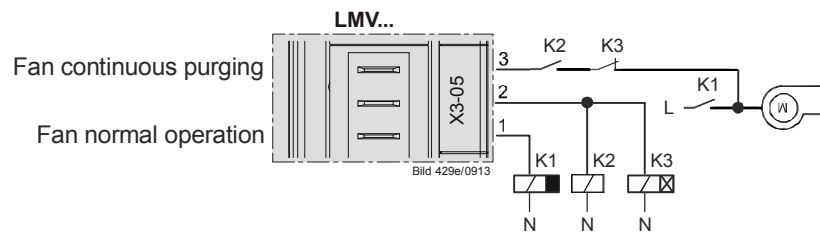

Figure 52: Application example of postpurging in the lockout position with fan but without VSD

The duration of postpurging in the lockout position can be set via the delay time of K3.



Attention!

When the *Postpurging in the lockout position* function is used, the fan may only be powered via a contactor and must not be connected directly to LMV36 (X3-05 pin 1)!

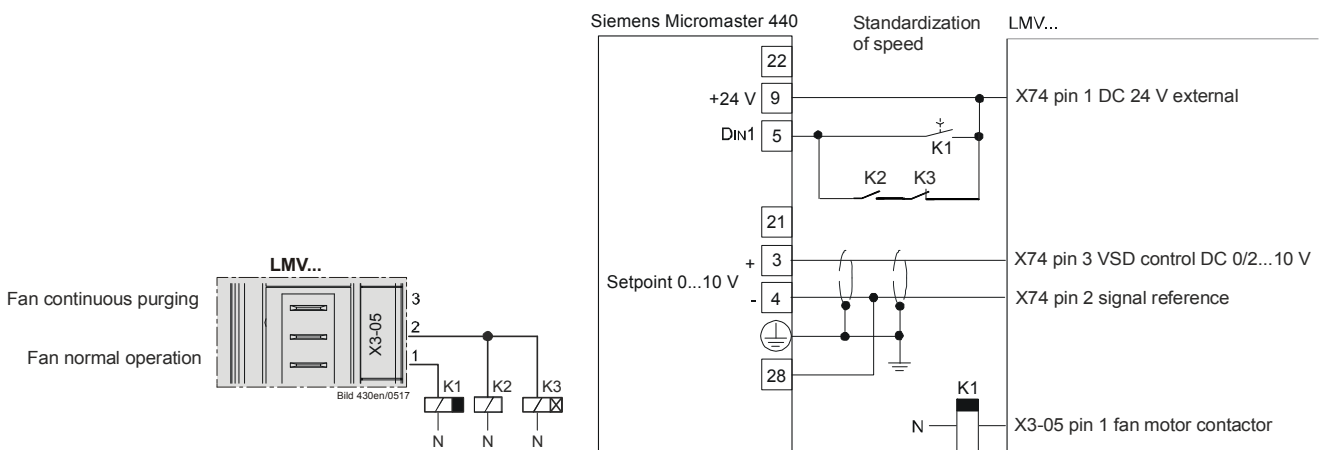

Figure 53: Application example of postpurging in the lockout position with fan and VSD release contact

The duration of postpurging in the lockout position can be set via the delay time of K3.



Attention!

When the *Postpurging in the lockout position* function is used, the fan may only be powered via a contactor and must not be connected directly to LMV36 (X3-05 pin 1)!

7.6 Fuel trains (application examples)

Gas direct ignition
(Operating mode 1, 7, 14, 19, 28)

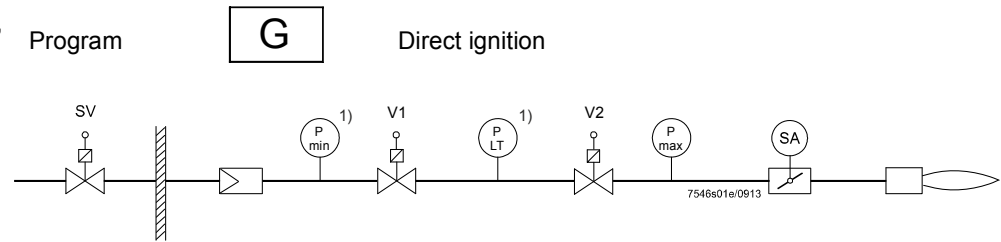

Figure 54: Gas direct ignition

Gas pilot ignition 1
(Operating mode 2, 8, 15, 20)

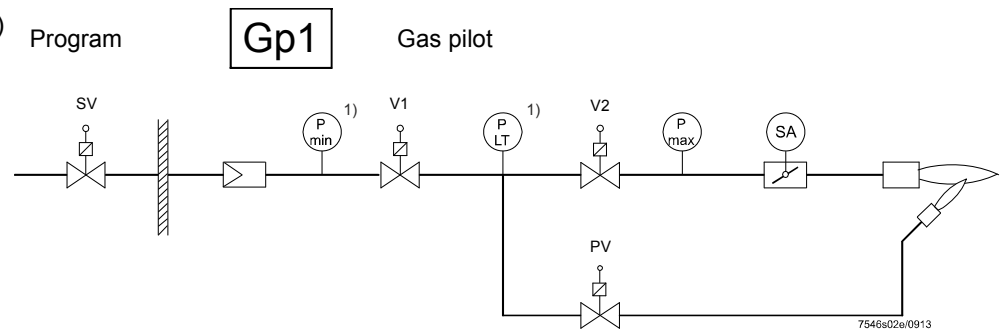

Figure 55: Gas pilot ignition 1

Gas pilot ignition 2
(Operating mode 3, 9, 16, 21, 29)

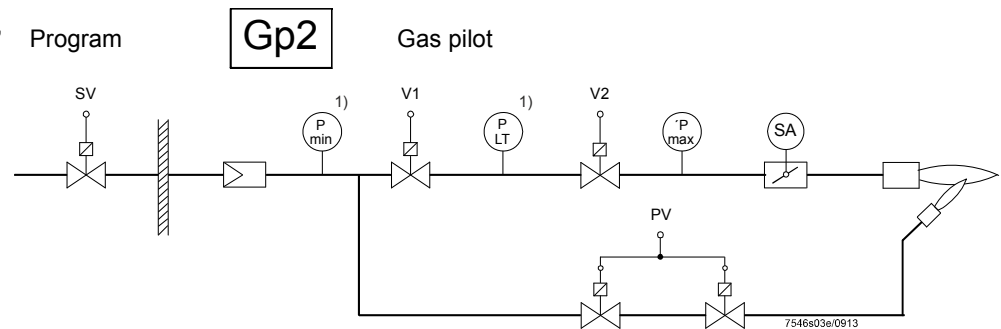

Figure 56: Gas pilot ignition 2

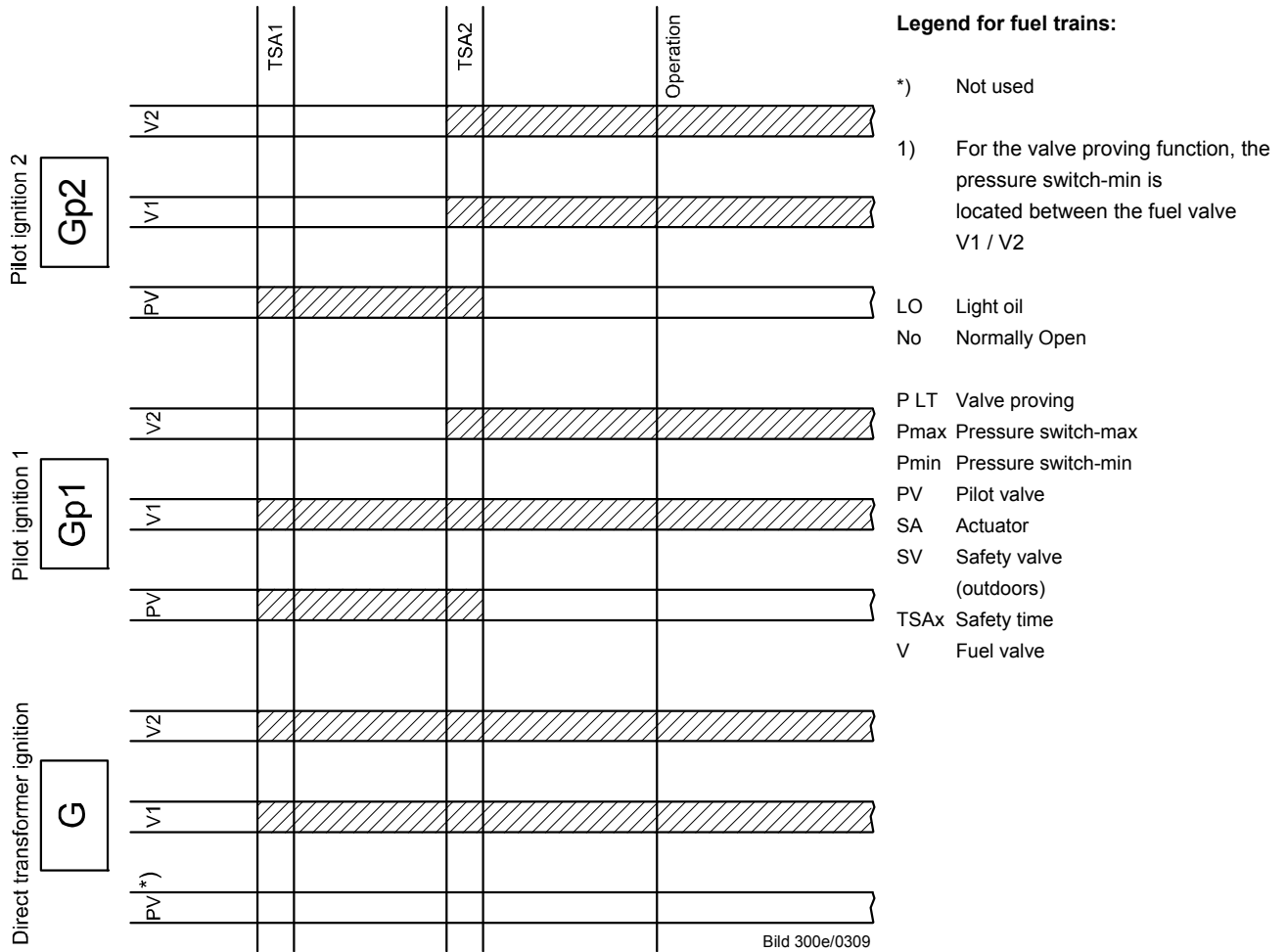

Figure 57: Gas – fuel valve control

Light oil direct ignition,
multistage
(Operating mode 5, 17)

1-stage burner

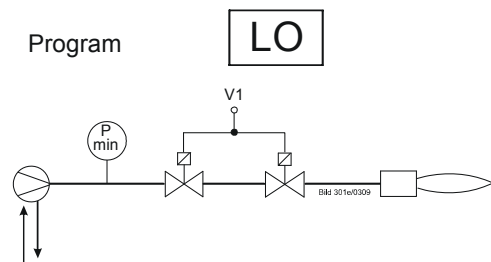

Figure 58: Light oil direct ignition, multistage

(Operating mode 5, 17)

2-stage burner

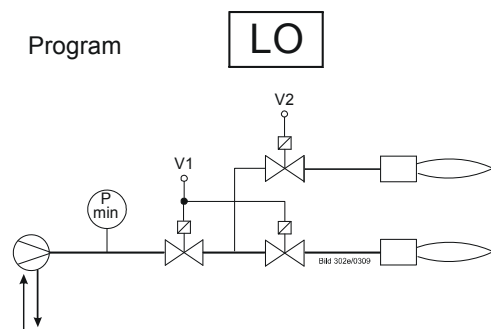

Figure 59: Light oil direct ignition, 2-stage

(Operating mode 6, 18)

3-stage burner

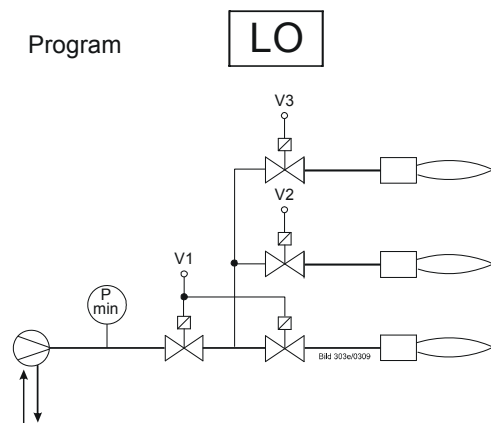

Figure 60: Light oil direct ignition, 3-stage

Light oil direct ignition,
modulating
(Operating mode 4, 22)

Modulating burner (without shutdown facility for adjustable head)

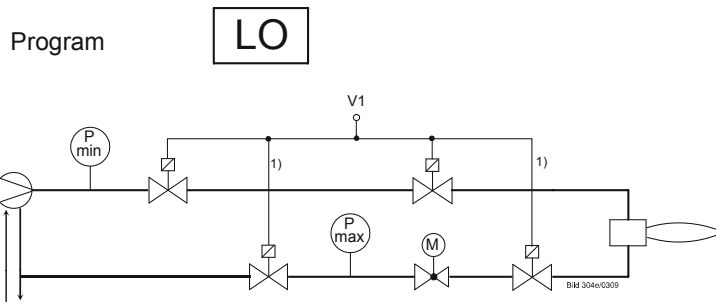

Figure 61: Light oil direct ignition, modulating

(Operating mode 4, 22)

Modulating burner (with shutdown facility for adjustable head)

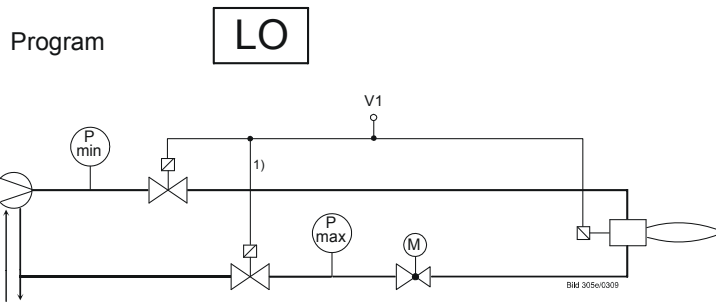

Figure 62: Light oil ignition, modulating

Fuel valve control

Light oil (transformer for direct ignition)

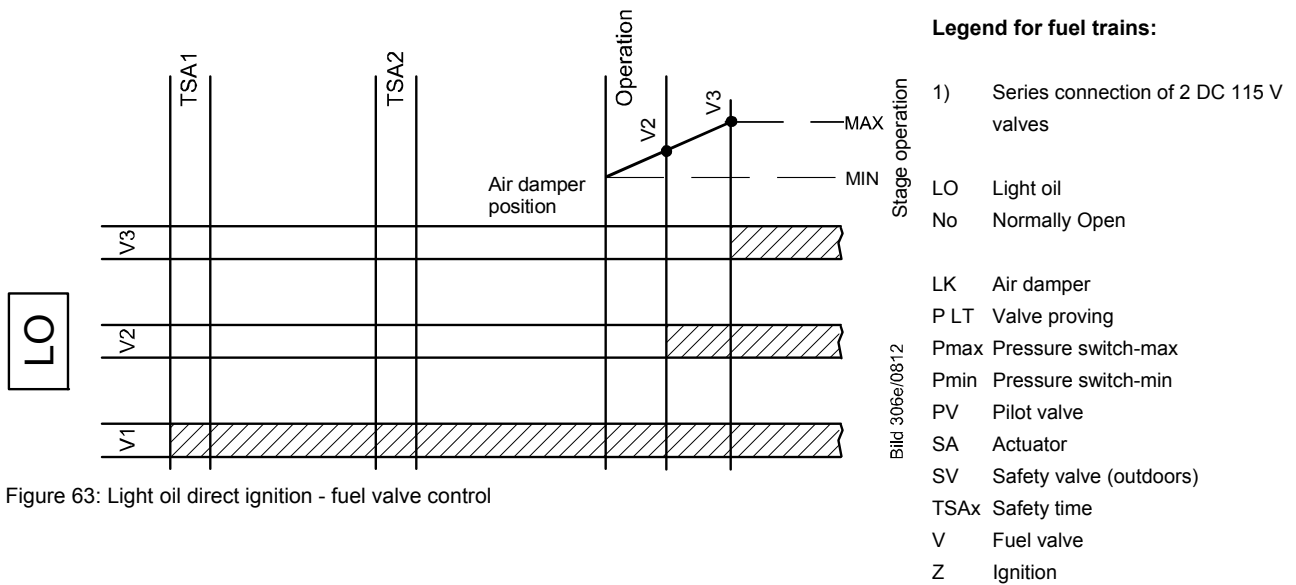
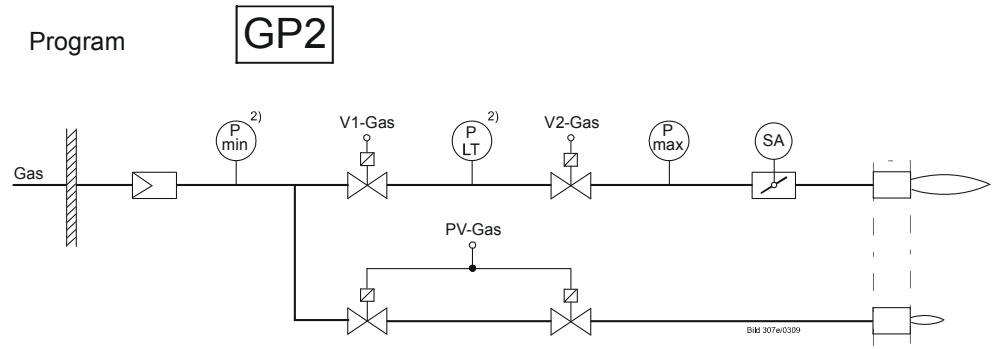

Figure 63: Light oil direct ignition - fuel valve control

Dual fuel burner gas/ light oil
with gas pilot ignition
(Operating mode 3, 9, 16, 21)



(Operating mode 10, 11)

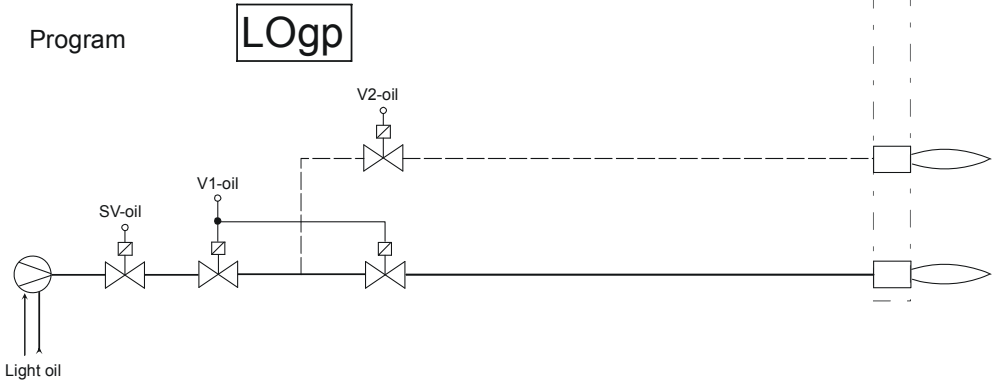

Figure 64: Dual fuel burner gas / light oil with gas pilot ignition

Fuel valve control

Light oil (with gas pilot ignition)

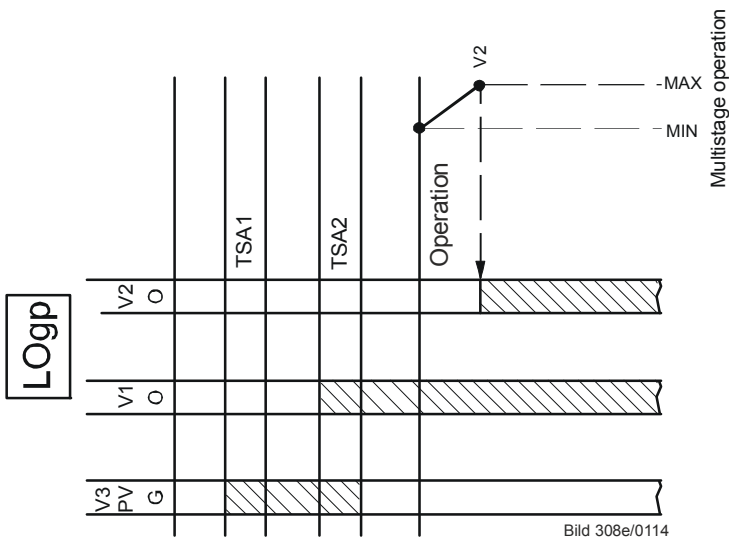

Figure 65: Light oil – gas pilot ignition – fuel valve control

Legend for fuel trains:

2) For the valve proving function, the pressure switch-min is located between the fuel valve V1 / V2

- LO Light oil
- No Normally Open
- LK Air damper
- P LT Valve proving
- Pmax Pressure switch-max
- Pmin Pressure switch-min
- PV Pilot valve
- SA Actuator
- SV Safety valve (outdoors)
- TSAx Safety time
- V Fuel valve
- Z Ignition

Light oil direct ignition
modulating with 2 fuel valves
(Operating mode 12)

Modulating burner (without shutdown facility for adjustable head)

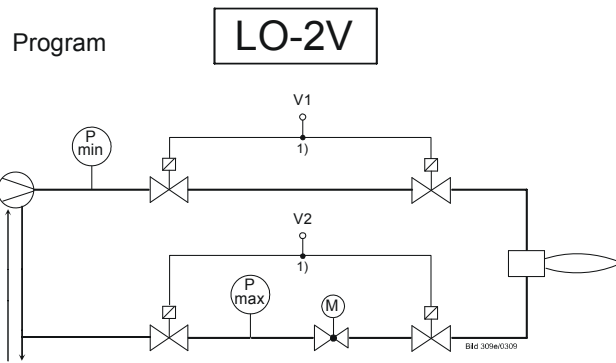

Figure 66: Light oil – direct ignition, modulating, without shutdown facility for adjustable head

(Operating mode 12)

Modulating burner (with shutdown facility for adjustable head)

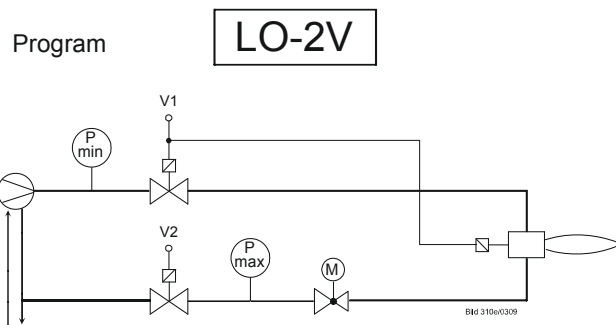

Figure 67: Light oil – direct ignition, modulating, with shutdown facility for adjustable head

Fuel valve control

Light oil (transformer for direct ignition)

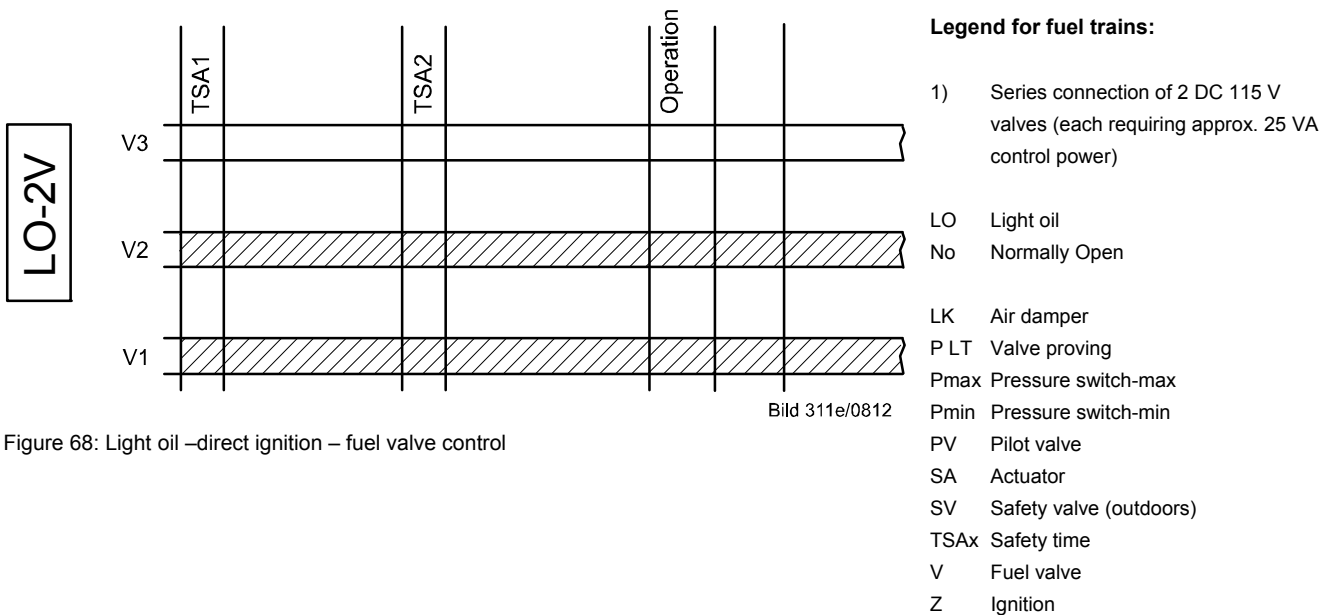
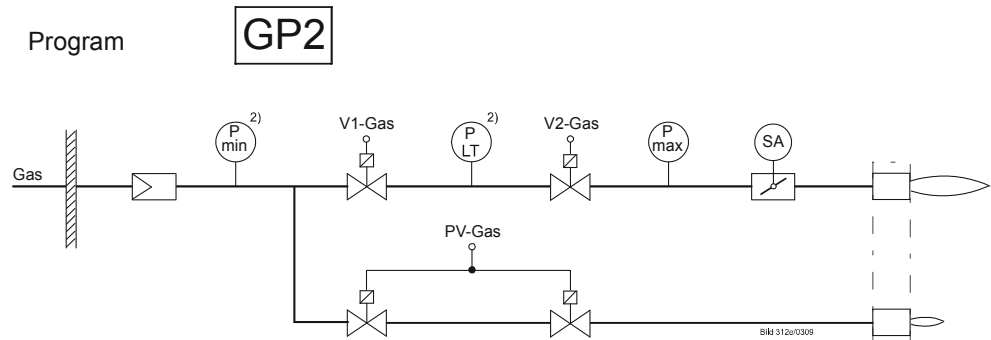

Figure 68: Light oil –direct ignition – fuel valve control

Dual fuel burner gas / light oil
with gas pilot ignition with 2
fuel valves
(Operating mode 3, 9, 16, 21)



(Operating mode 13)

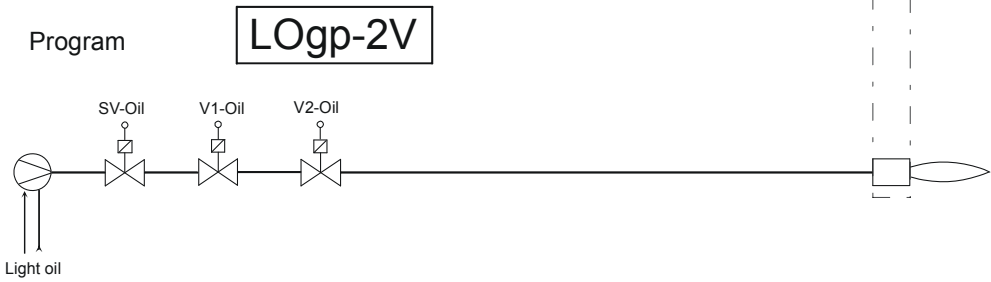

Figure 69: Dual fuel burner gas / light oil with gas pilot ignition, with 2 fuel valves

Fuel valve control

Light oil (with gas pilot ignition)

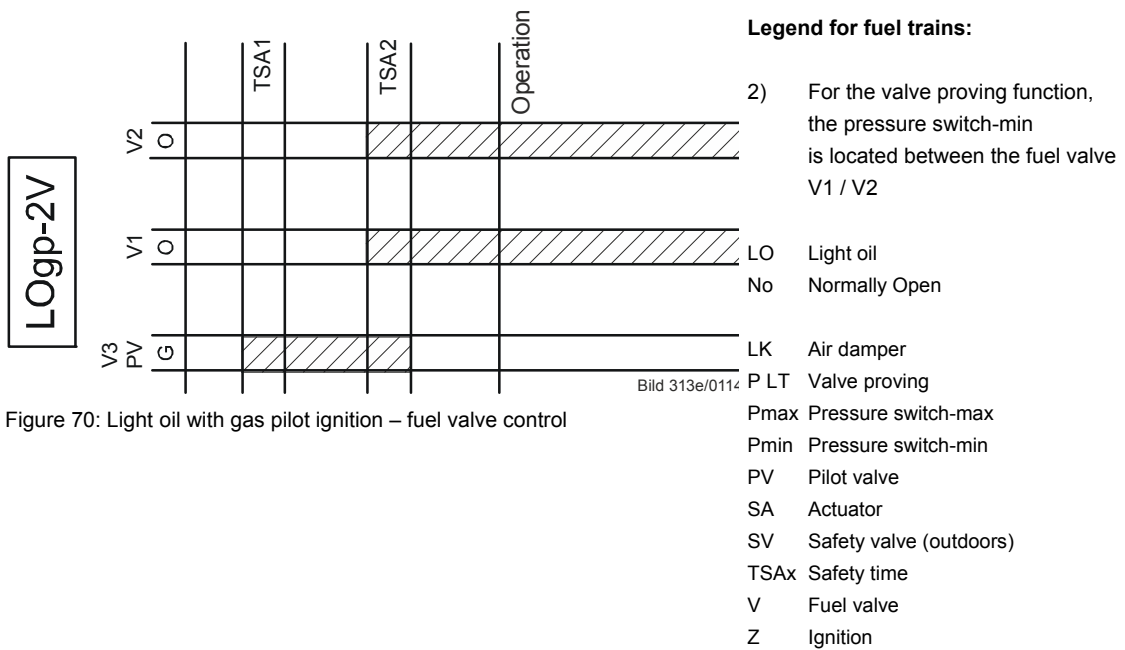

Figure 70: Light oil with gas pilot ignition – fuel valve control

Light oil with gas pilot ignition

(Operating mode 3, 9, 16, 21)

Program

LOgp

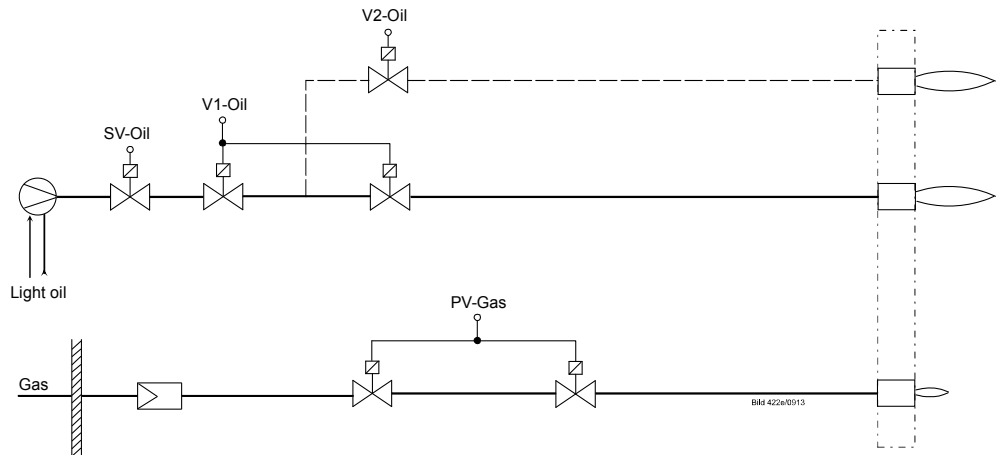

(Operating mode 10, 11)

Figure 71: Light oil with gas pilot ignition

Fuel valve control

Light oil (with gas pilot ignition)

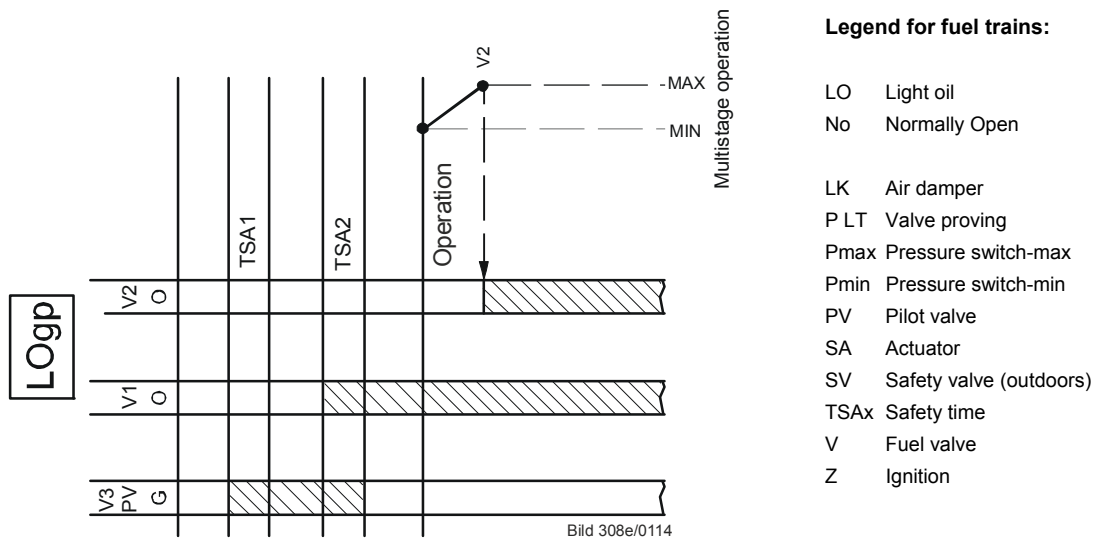
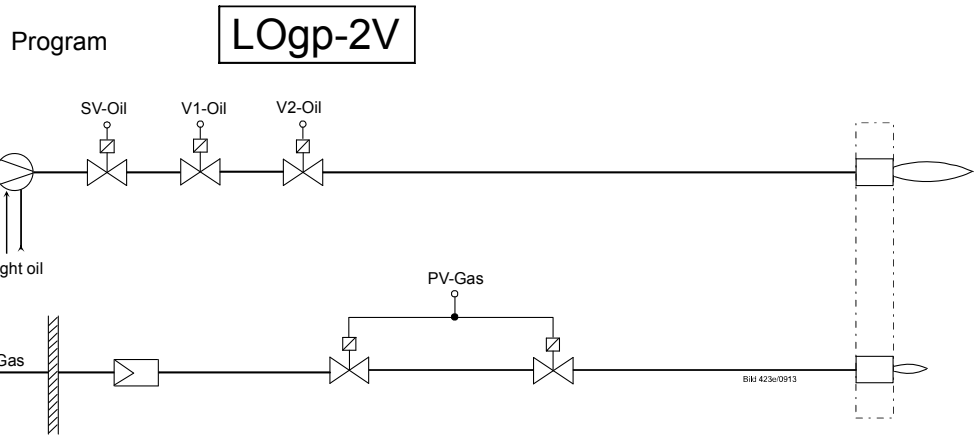

Figure 72: Light oil with gas pilot ignition – fuel valve control

Light oil with gas pilot ignition
with 2 fuel valves

(Operating mode 3, 9, 16, 21)



(Operating mode 13)

Figure 73: Light oil with gas pilot ignition

Fuel valve control

Light oil (with gas pilot ignition)

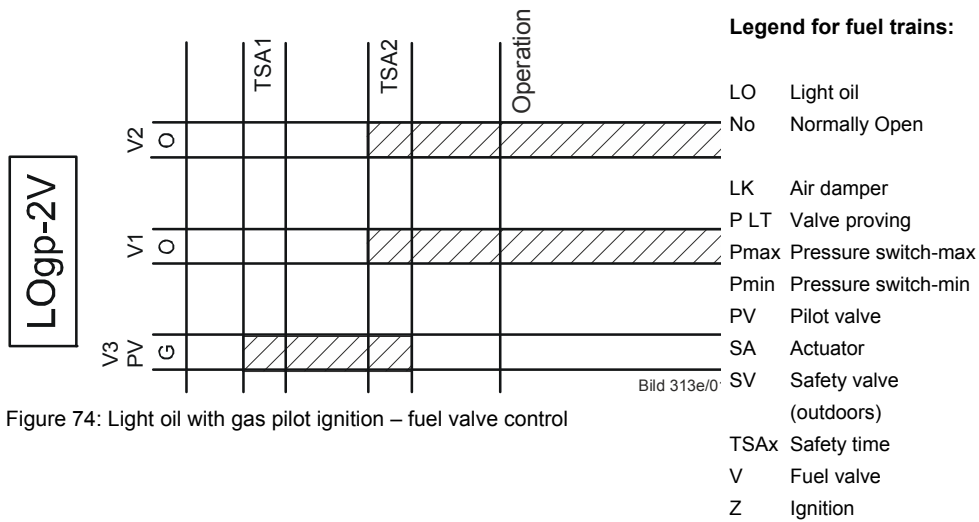

Figure 74: Light oil with gas pilot ignition – fuel valve control

7.7 Sequence diagrams

The phase numbers given in the sequence diagrams can be read from the following process data:

No.	Parameter
961	Phase (state for external module and display)

7.7.1 Gas direct ignition «G», «G mod», «G mod pneu»



Bild 06e/0913

Figure 75: Program for gas direct ignition (G), (G mod), (G mod pneu)

7.7.2 Gas pilot ignition 1 «Gp1», «Gp1 mod», «Gp1 mod pneu»

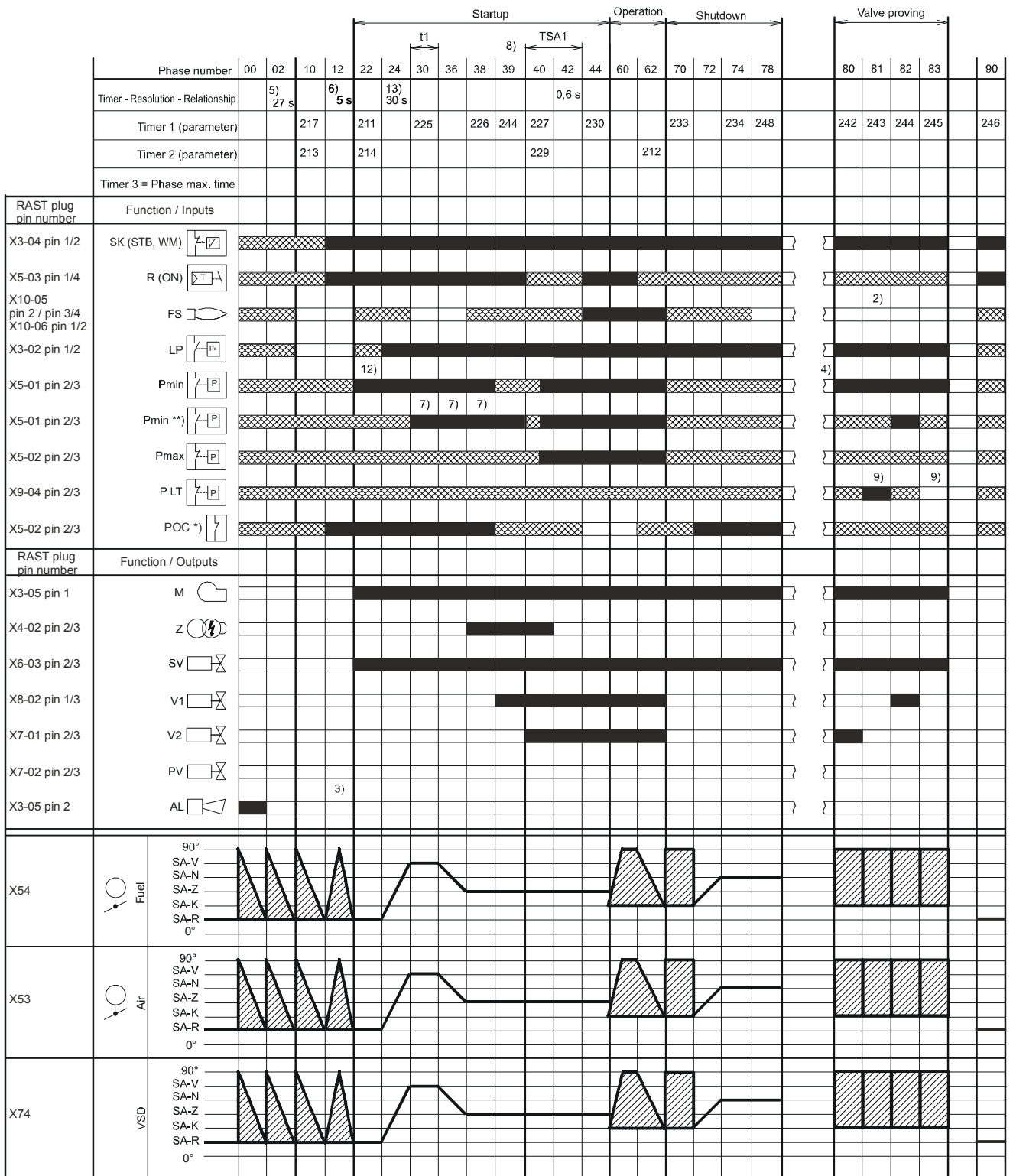
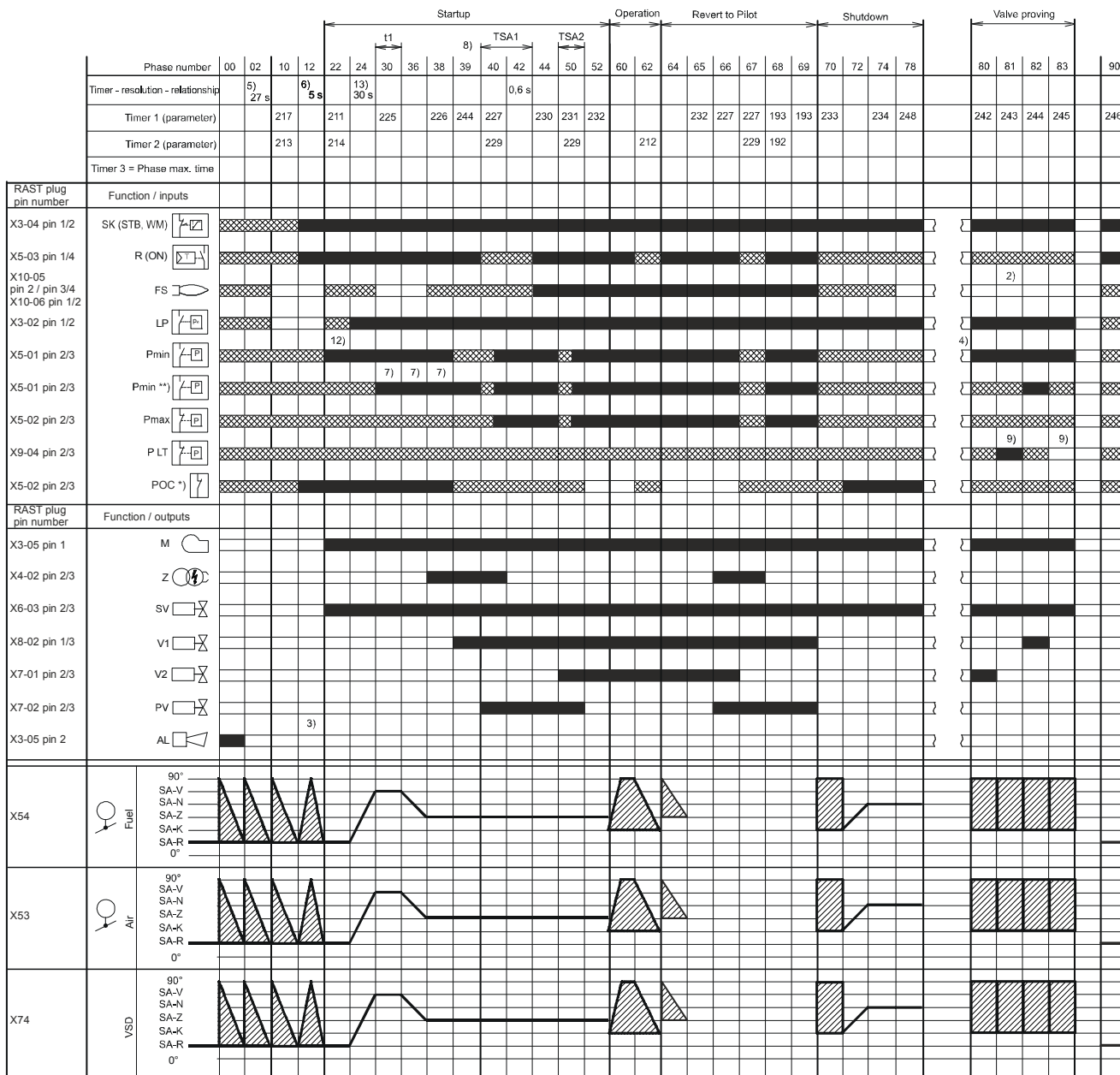

BlH 18e/0913

Figure 76: Program for gas pilot ignition (Gp1), (Gp1 mod), (Gp1 mod pneu)

7.7.3 Gas pilot ignition 2 «Gp2», «Gp2 mod», «Gp2 mod pneu»



Bild 19e/0913

Figure 77: Program for gas pilot ignition (Gp2), (Gp2 mod), (Gp2 mod pneu)

7.7.4 Light oil direct ignition «Lo», «Lo mod», «Lo 2-stage», «Lo 3-stage»

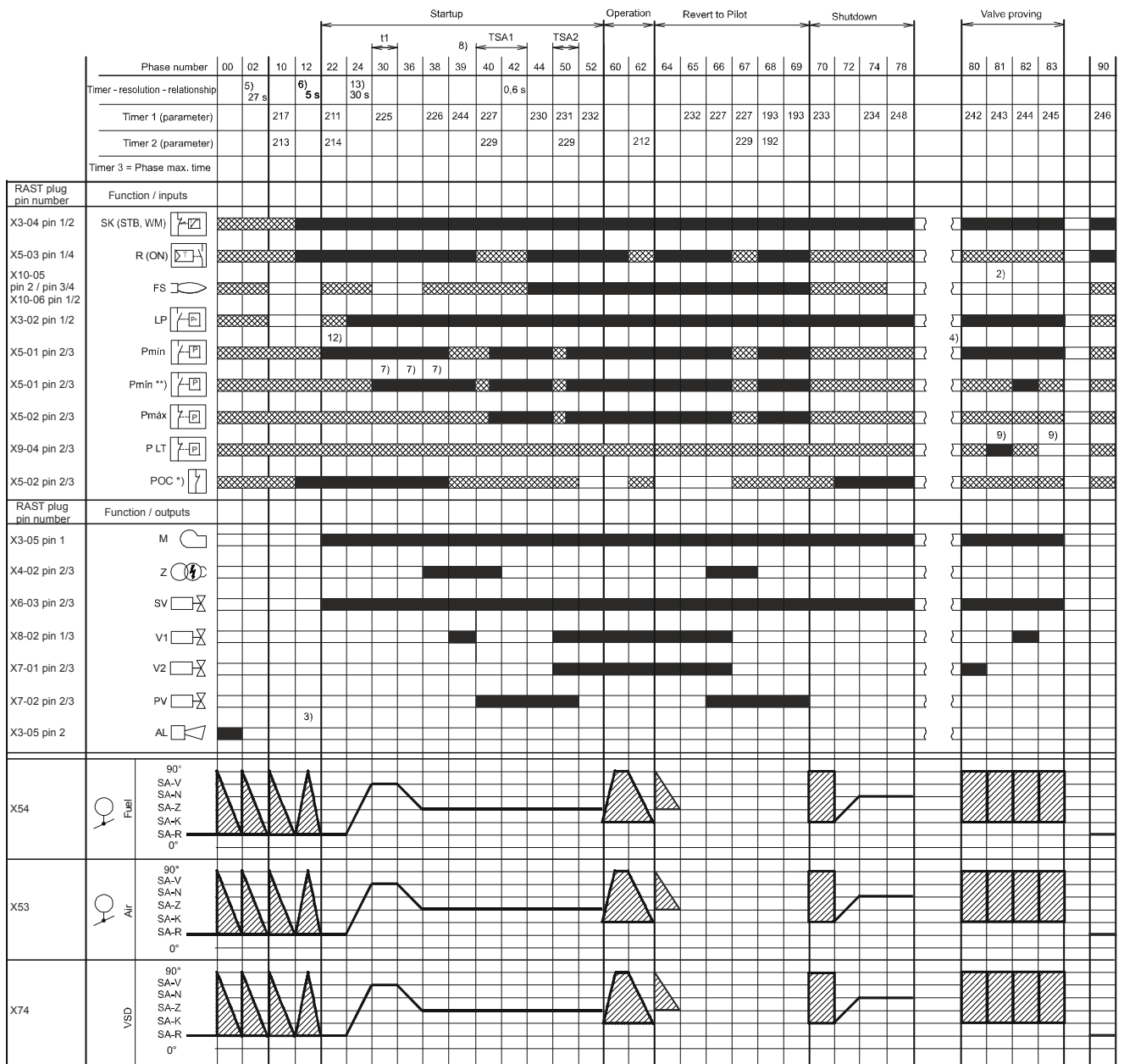

Bild 03e/1010

Figure 78: Program for light oil direct ignition (Lo), (Lo mod), (Lo 2-stage), (Lo 3-stage)

7.7.5 Light oil pilot ignition «LoGp» «LoGp mod» «LoGp 2 stage»

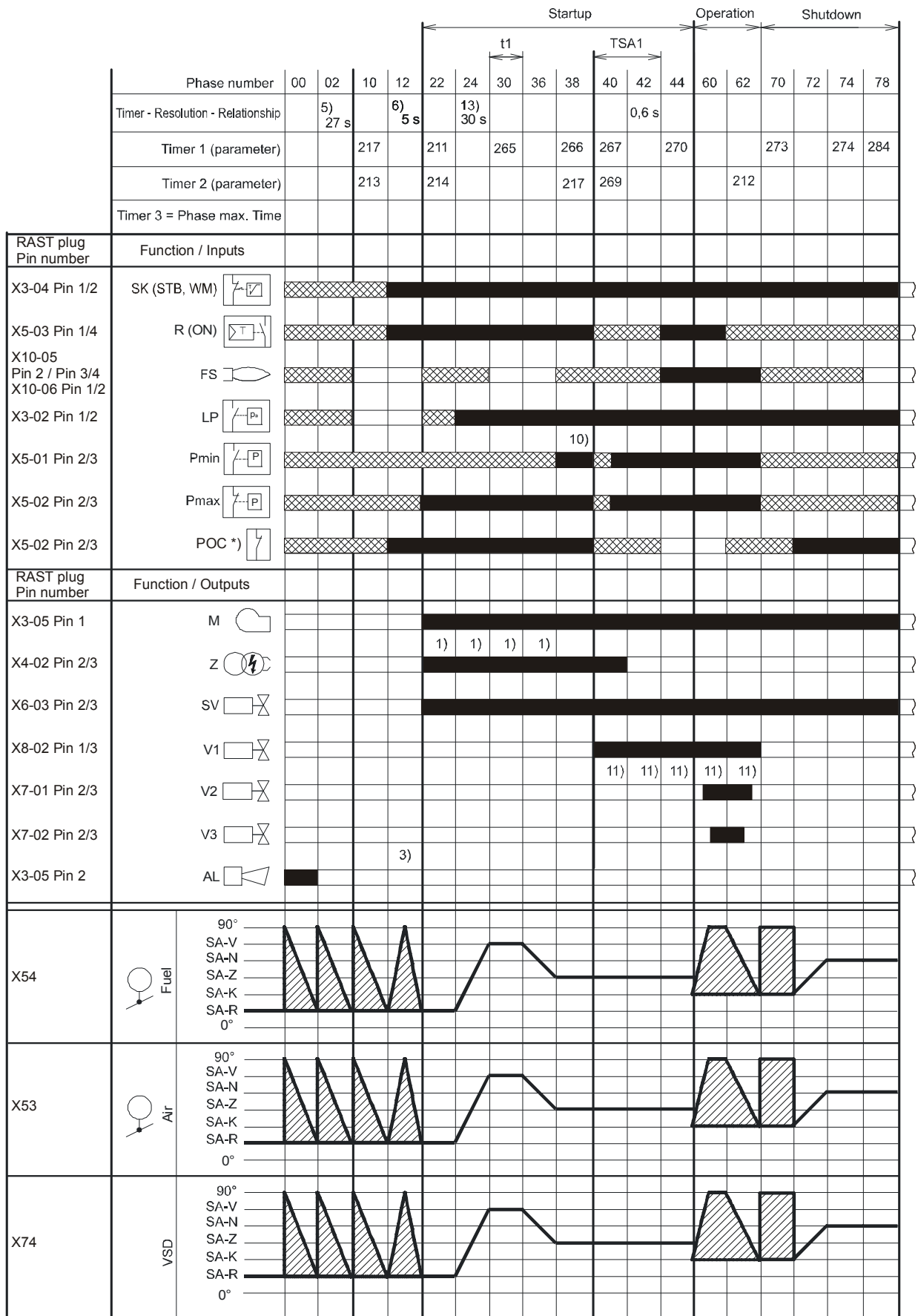

Bild 01e/1010

Figure 79: Program light pilot ignition «LoGp» «LoGp mod» «LoGp 2 stage»

7.7.6 Legend to the sequence diagrams

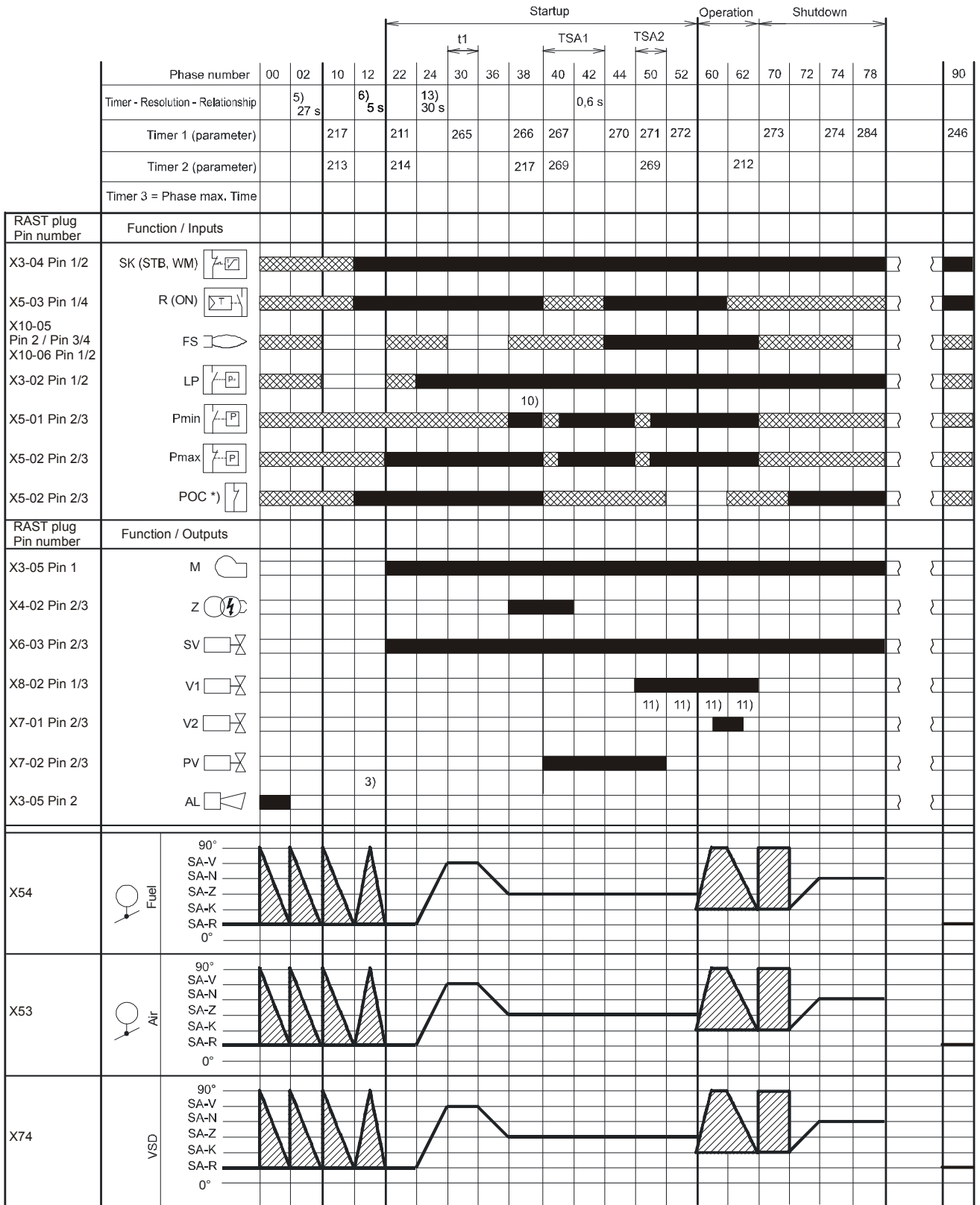

Note

Not all phases, times, indices, abbreviations and symbols appear in the individual sequence diagrams or are needed there!

Phase numbers

00	Lockout phase
02	Safety phase
10	Home run
12	Standby (stationary)
22	Fan motor = ON, safety valve = ON
24	Air damper ⇒ pre purge position
30	Prepurging
35	Fan ⇒ ignition speed
36	Air damper ⇒ ignition position
38	Preignition ignition = ON
39	Test pressure switch-min
40	Fuel valve = ON
42	Ignition = OFF
44	Interval 1
50	Second safety time
52	Interval 2
60	Operation 1 (stationary)
62	Operation 2 (air damper ⇒ low-fire position)
70	Afterburn time
71	Fan ⇒ postpurge speed
72	Air damper ⇒ Rated load position
74	Postpurge time
78	Postpurge time
79	Fan ⇒ standby speed
80	Evacuation of test space
81	Test time atmospheric pressure
82	Filling of test space
83	Test time gas pressure
90	Gas shortage waiting time

Valve proving is performed depending on the parameter settings:
Simultaneously with the prepurge time **and/or** the afterburn time.

Times

TSA1	1st safety time
TSA2	2nd safety time
t1	Prepurge time
t3	Postpurge time
t8	Postpurge time
t13	Afterburn time
t44	Interval 1
t52	Interval 2

Indices

1)	Parameter:	Short/long prepurge time for oil only Short/long oil pump – ON – time
2)		Only with valve proving during startup
3)	Parameter:	With/without alarm in the event of start prevention
4)		If signal is faulty in the startup phase, phase 10 is next, otherwise phase 70
5)		Maximum time safety phase, then lockout
6)		Time from occurrence of start prevention to signaling
7)		Only in case of valve proving during startup (valve proving via pressure switch-min)
8)		Only in case of startup without valve proving (valve proving via pressure switch -min)
9)		Inverse logic in case of valve proving via pressure switch-min
10)	Parameter 276:	Oil: Input oil pressure min 1 = active from phase 38 2 = active from safety time
11)		Only with fuel train <i>Lo</i> and 2 fuel valves
12)	Parameter 223:	Repetition limit value gas pressure switch-min in connection with gas shortage program parameter 246 (phase 90) 1 = no repetition 2...15 = 1...14 number of repetitions 16 = constant repetition
13)		Maximum drop-in/response time for air pressure switch
14)		Alternative to valve proving
15)		Alternative to pressure switch-max or POC

Abbreviations

AL	Alarm
FS	Flame signal
GM	Fan motor contactor
LP	Air pressure switch
M	Fan motor
P LT	Pressure switch for valve proving
Pmax	Pressure switch-max
Pmin	Pressure switch-min
POC	Proof of closure
PV	Pilot valve
R	Temperature or pressure controller
SB	Safety limiter
SK	Safety loop
STB	Safety limit thermostat
SV	Safety valve
WM	Water shortage
V1	Fuel valve V1
V2	Fuel valve V2
VP	Combustion pressure switch
Z	Ignition transformer
SA	Actuator
SA-K	Low-fire position of actuator
SA-N	Postpurge position of actuator
SA-R	Home position of actuator
SA-V	Rated load position of actuator
SA-Z	Ignition load position of actuator

Symbols



Permissible position range



In *Standby* mode: Actuator is allowed to travel within the permissible position range, but is always driven to the home position; must be in the home position for phase changes

0°/10%
90°/100%

Position as supplied (0°)
Actuator fully open (90°)



Input/output signal 1 (ON)
Input/output signal 0 (OFF)
Input permissible signal 1 (ON) or 0 (OFF)

*)

Alternative to pressure switch-max

**)

Only with valve proving via pressure switch-min

8 AGM60

8.1 LMV36 with AGM60 and one fuel actuator

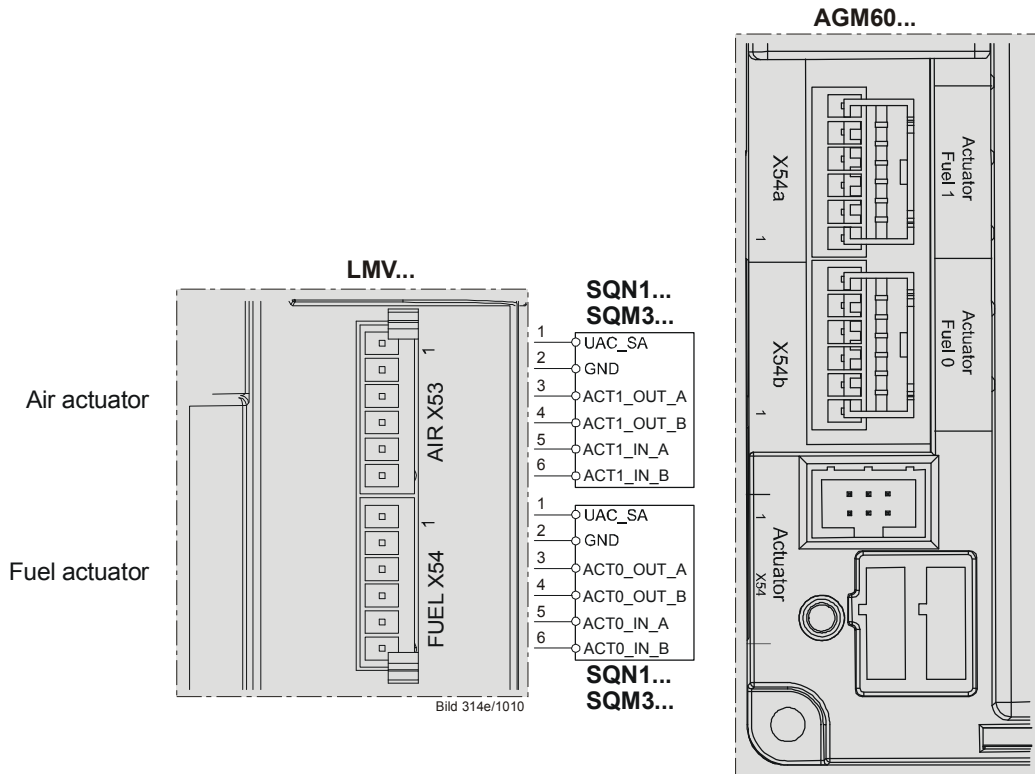

Figure 80: LMV36 with AGM60 and one fuel actuator

8.2 LMV36 with AGM60 and two fuel actuators

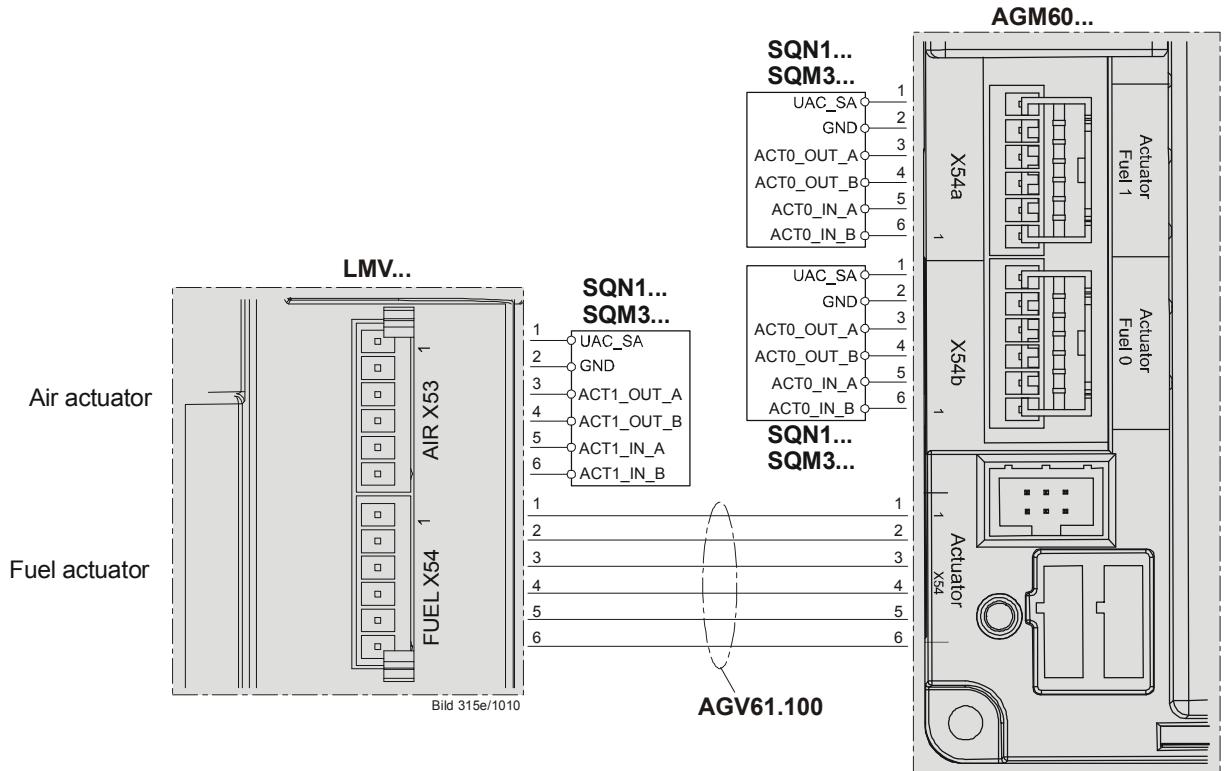

Figure 81: LMV36 with AGM60 and two fuel actuator

8.3 Connecting cable between AGM60 and LMV36 (AGV61.100 cable)

This cable is required when, due to the selected type of fuel train (refer to chapter *Selection of operating mode*), 2 fuel actuators are needed.

For that, the 2 fuel actuators must be connected to terminals X54a and X54b of the AGM60. The AGV61.100 cable is required for making the electrical connection between the 2 fuel actuators and the LMV36.

If only 1 fuel actuator is used, it must be connected directly to the LMV36.

Connection plug assignment of cable:

1 = pink or alternatively red

2 = white or alternatively black

3 = brown

4 = grey

5 = yellow

6 = green

9 Selection of operating mode

To facilitate straightforward adaptation of the LMV36 to different types of burners, the LMV36 offers automatic configuration of the operating mode. This means that – derived from parameter 201 / 301 (fuel 1) – the most important settings of configurations relating to the operating mode are made automatically. Very often in that case, the only manual settings to be made are those for the fuel-air ratio control system. After selection of the operating mode, parameters that are not required will be hidden (e.g. oil parameters when firing on gas).

No.	Parameter
201	Burner operating mode (fuel train, modulating / multistage, actuators, etc.) -- = undefined (delete curves) 1 = G mod 2 = Gp1 mod 3 = Gp2 mod 4 = Lo mod 5 = Lo 2-stage 6 = Lo 3-stage 7 = G mod pneu 8 = Gp1 mod pneu 9 = Gp2 mod pneu 10 = LoGp mod 11 = LoGp 2-stage 12 = Lo mod 2 fuel valves 13 = LoGp mod 2 fuel valves 14 = G mod pneu without actuator 15 = Gp1 mod pneu without actuator 16 = Gp2 mod pneu without actuator 17 = Lo 2-stage without actuator 18 = Lo 3-stage without actuator 19 = G mod gas actuator only 20 = Gp1 mod gas actuator only 21 = Gp2 mod gas actuator only 22 = Lo mod oil actuator only 23 = Ho mod separate circulation control ¹⁾ 24 = Ho 2-stage separate circulation control ¹⁾ 25 = Ho mod without circulation control ¹⁾ 26 = Ho 2-stage without circulation control ¹⁾ 27 = Ho 3-stage without circulation control ¹⁾ 28 = G mod mech air actuator only 29 = Gp2 mod mech air actuator only ¹⁾ Selected operating mode is not released for the LMV36. With select: Error code 210 diagnostic code 0

No.	Parameter
301	<p>Fuel 1: Burner operating mode (fuel train, modulating / multistage, actuators, etc.)</p> <p>-- = undefined (delete curves)</p> <p>1 = G mod</p> <p>2 = Gp1 mod</p> <p>3 = Gp2 mod</p> <p>4 = Lo mod</p> <p>5 = Lo 2-stage</p> <p>6 = Lo 3-stage</p> <p>7 = G mod pneu</p> <p>8 = Gp1 mod pneu</p> <p>9 = Gp2 mod pneu</p> <p>10 = LoGp mod</p> <p>11 = LoGp 2-stage</p> <p>12 = Lo mod 2 fuel valves</p> <p>13 = LoGp mod 2 fuel valves</p> <p>14 = G mod pneu without actuator</p> <p>15 = Gp1 mod pneu without actuator</p> <p>16 = Gp2 mod pneu without actuator</p> <p>17 = Lo 2-stage without actuator</p> <p>18 = Lo 3-stage without actuator</p> <p>19 = G mod gas actuator only</p> <p>20 = Gp1 mod gas actuator only</p> <p>21 = Gp2 mod gas actuator only</p> <p>22 = Lo mod oil actuator only</p> <p>23 = HO mod with circulation control ¹⁾</p> <p>24 = HO 2-stage with circulation control ¹⁾</p> <p>25 = HO mod without circulation control ¹⁾</p> <p>26 = HO 2-stage without circulation control ¹⁾</p> <p>27 = HO 3-stage without circulation control ¹⁾</p> <p>28 = G mod mech only air actuator</p> <p>29 = Gp2 mod mech only air actuator</p> <p>¹⁾ Selected operating mode is not released for the LMV36. With select: Error code 210 diagnostic code 0</p>

Operating mode parameter 201 / 301	Fuel train	Fuel-air ratio control	Fuel actuator	Air actuator	Feedback signal VSD	Description
1	G mod	Modulating electronic	•	•	•	Gas direct ignition, electronic modulating ratio control. Optional with VSD with speed feedback signal
2	Gp1 mod	Modulating electronic	•	•	•	Gas pilot ignition 1, electronic modulating ratio control. Optional with VSD with speed feedback signal
3	Gp2 mod	Modulating electronic	•	•	•	Gas pilot ignition 2, electronic modulating ratio control. Optional with VSD with speed feedback signal
4	Lo mod	Modulating electronic	•	•	•	Oil direct ignition, electronic modulating ratio control. Optional with VSD with speed feedback signal
5	Lo 2-stage	2-stage		•	•	Oil direct ignition, electronic 2-stage ratio control. Optional with VSD with speed feedback signal
6	Lo 3-stage	3-stage		•	•	Oil direct ignition, electronic 3-stage ratio control. Optional with VSD with speed feedback signal
7	G mod pneu	Modulating pneumatic		•		Gas direct ignition, pneumatic modulating ratio control. Optional with VSD.
8	Gp1 mod	Modulating		•		Gas pilot ignition 1, pneumatic modulating ratio control.

102/283

Operating mode parameter 201 / 301	Fuel train	Fuel-air ratio control	Fuel actuator	Air actuator	Feedback signal VSD	Description
	pneu	pneumatic				Optional with VSD.
9	Gp2 mod pneu	Modulating pneumatic		•		Gas pilot ignition 2, pneumatic modulating ratio control. Optional with VSD.
10	LoGp mod	Modulating electronic	•	•	•	Oil pilot ignition, electronic modulating ratio control. Optional with VSD with speed feedback signal
11	LoGp 2-stage	2-stage		•	•	Oil pilot ignition, electronic 2-stage ratio control. Optional with VSD with speed feedback signal
12	Lo mod 2 fuel valves	Modulating electronic	•	•	•	Oil direct ignition, 2 fuel valves, electronic modulating ratio control. Optional with VSD with speed feedback signal
13	LoGp mod 2 fuel valves	Modulating electronic	•	•	•	Oil pilot ignition, 2 fuel valves, electronic modulating ratio control. Optional with VSD with speed feedback signal
14	G mod pneu without actuator	Modulating pneumatic				Gas direct ignition, without actuator, pneumatic modulating ratio control. Optional with VSD.
15	Gp1 mod pneu without actuator	Modulating pneumatic				Gas pilot ignition 1, without actuator, pneumatic modulating ratio control. Optional with VSD.
16	Gp2 mod pneu without actuator	Modulating pneumatic				Gas pilot ignition 2, without actuator, pneumatic modulating ratio control. Optional with VSD.
17	Lo 2-stage without actuator	2-stage			•	Oil direct ignition, without actuator, electronic 2-stage ratio control. Optional with VSD with speed feedback signal
18	Lo 3-stage without actuator	3-stage			•	Oil direct ignition, without actuator, electronic 3-stage ratio control. Optional with VSD with speed feedback signal
19	G mod only gas actuator	Modulating electronic	•		•	Gas direct ignition, only gas actuator. modulating ratio control. Optional with VSD with speed feedback signal
20	Gp1 mod only gas actuator	Modulating electronic	•		•	Gas pilot ignition 1, only gas actuator. modulating ratio control. Optional with VSD with speed feedback signal
21	Gp2 mod only gas actuator	Modulating electronic	•		•	Gas pilot ignition 2, only gas actuator. modulating ratio control. Optional with VSD with speed feedback signal
22	Lo mod only oil actuator	Modulating electronic	•		•	Oil direct ignition, only oil actuator. modulating ratio control. Optional with VSD with speed feedback signal
23	Ho mod separate circulation control	Modulating electronic	•	•	•	Heavy oil direct ignition, with circulation control, electronic modulating ratio control. Optional with VSD with speed feedback signal
24	Ho 2 stage separate circulation control	2-stage		•	•	Heavy oil direct ignition, with circulation control, electronic 2-stage ratio control. Optional with VSD with speed feedback signal
25	Ho mod without circulation control	Modulating electronic	•	•	•	Heavy oil direct ignition, without circulation control, electronic modulating ratio control. Optional with VSD with speed feedback signal
26	Ho 2 stage without circulation control	2-stage		•	•	Heavy oil direct ignition, without circulation control, electronic 2-stage ratio control. Optional with VSD with speed feedback signal
27	Ho 3 stage	3-stage		•	•	Heavy oil direct ignition, without circulation control, electronic 3-

Operating mode parameter 201 / 301	Fuel train	Fuel-air ratio control	Fuel actuator	Air actuator	Feedback signal VSD	Description
	without circulation control					stage ratio control. Optional with VSD with speed feedback signal
28	G mod mech only air actuator	Modulating mechanical		•	•	Gas direct ignition, only air actuator, mechanical modulating ratio control. Optional with VSD with speed feedback signal
29	Gp2 mod mech only air actuator	Modulating mechanical		•	•	Gas pilot ignition 2, only air actuator, mechanical modulating ratio control. Optional with VSD with speed feedback signal

1) Selected operating mode is not released for the LMV36.
With select: Error code 210 diagnostic code 0

(Also refer to chapter *Fuel trains*)

The VSD can be used with any of the operating modes (refer to chapter *VSD*).

No.	Parameter
542	Activation of VSD / PWM fan 0 = deactivated 1 = activated 2 = activated (no repetition)



Note

For configuration of the analog output when the VSD is activated, refer to chapter *Load output X74 pin 3!*

9.1 Deleting curves

To delete curves, the operating mode must be set to undefined «--». In that case, only the fuel curves are deleted, the direction of rotation or the reference position of the actuators is not changed.

10 Connection to load controllers

The LMV36 can be connected to different load controllers. The heat request and the required burner output are determined in accordance with the priorities of the different heat sources.

10.1 Load controller ON contact X5-03 pin 1

This contact is given priority over all load controller sources. A heat request can be made only when this contact is closed. The contact is safety-related and can also be used in connection with load controllers featuring an integrated temperature limiter function.

10.2 Load controller via building automation system X92

To control the LMV36, the building automation system can predefine an output via a bus system. The building automation system is connected to the LMV36 via the X92 interface.

Burner startup can take place only when contact X5-03 pin 1 is closed (load controller ON / OFF).

Further information on connecting the building automation system to the LMV36 can be found in this documentation in section *Connection to superordinated systems* and the user documentation Modbus (A7541).

Minimum positioning step

To avoid unnecessary positioning steps of the actuators when the predefined target output varies, a minimum positioning step can be set. The LMV36 changes the output only if the change in target output exceeds the minimum positioning step. The minimum positioning step only becomes active in modulating operation.

No.	Parameter
123.0	Minimum output positioning step: Output building automation

Behavior in the event the building automation and control system fails

If the LMV36 receives no more data from building automation, it will deliver the output set with parameter 148 / 149.

The time that elapses until communication breakdown is detected can be set via parameter 142.

No.	Parameter
142	<p>Setback time in the event of communication breakdown</p> <p>Setting value: 0 = deactivated 1...7200 s</p>
148	<p>Predefined output in the event of communication breakdown with building automation</p> <p>Setting values: For modulating operation, the setting range is as follows: 0...19.9 = burner off 20...100 = 20...100% burner output (20 = low-fire position)</p> <p>For multistage operation, use the following settings: 0 = burner OFF P1...P3 = stage 1...stage 3</p> <p>Invalid = no output predefined by the building automation system in the event of communication breakdown</p> <p>Default setting: <i>Invalid</i></p>
149	<p>Fuel 1: Predefined output in the event of communication breakdown with building automation</p> <p>Setting values: For modulating operation, the setting range is as follows: 0...19.9 = burner off 20...100 = 20...100% burner output (20 = low-fire position)</p> <p>For multistage operation, use the following settings: 0 = burner OFF P1...P3 = stage 1...stage 3</p> <p>Invalid = no output predefined by the building automation system in the event of communication breakdown</p> <p>Default setting: <i>Invalid</i></p>

Setting choices:

- a) Set output specification in parameter 148 / 149 to *undefined* (--).
In the event communication breaks down, the last valid preselected output is maintained. The next load controller activated in accordance with the priority (refer to chapter *Prioritization of load controller sources*) ensures control from this output position.
- b) Output preset via parameter 148 / 149 set to 0, 20...100%, or parameterized as multistage:
If communication breaks down, the output requested by the building automation system is set invalid and the output set via parameter 148 / 149 is delivered.



Note

In that case, outputs via load controllers with a priority lower than that of the building automation system cannot be delivered.

10.3 Manual output

A manual output can be set with the *Normal display* of the AZL2 or via the PC software ACS410.

Manual output via the AZL2

Manual output can be activated or adjusted by keeping the **F** button depressed for at least 1 second and by pressing the **+** or **-** button.

Output **0** means *Manually off*.

As long as manual output is active, the output appearing on the normal display blinks.

To deactivate and to change to automatic operation, press **Esc** for 3 seconds.

If *Manually off* is activated, it is stored via mains OFF.

On power return, the burner assumes the *Manually off* position (**OFF** blinking) (refer to chapter *Operation*).

Fuel changeover resets the manual output to *Invalid*.

Exception:

Setting *Manually off* is maintained after fuel changeover also.

Activation of *Manually off* in operation

To activate *Manually off*, first run the system to the minimum output limit. Then, keep the **F** button depressed for at least 1 second and press the **-** button.

Manually off is activated by releasing the **F** button and by pressing again the **-** button.



Caution!

***Manually off* must not be used by itself to put a burner out of operation when doing mounting work, or when the burner is not ready for operation. The safety notes in chapter *Safety notes* must be observed!**

Manual output via the PC software ACS410

Refer to description of the PC software ACS410 (J7352).

10.4 Output with curve settings

To set the curves via the AZL2 or the PC software ACS410, a special parameterization output is provided.

Using this output, it is also possible to approach the point of ignition. The output is delivered automatically and cannot be set manually. It is only mentioned here for the sake of completeness.

10.5 External load controller via analog input X64 pin 1 / X64 pin 2

For the preselection of external outputs, an analog 4...20 mA input is provided. Burner startup can take place only when contact X5-03 pin 1 is closed (load controller ON / OFF).

Switching thresholds / minimum positioning step

A disruption of the current input or a current signal <3 mA leads to deactivation of the analog input's external preselected output.

The behavior of the LMV36 in the event of an invalid analog input can be defined.

To avoid unnecessary positioning steps of the actuators when the input signal varies, it is possible to set a minimum positioning step for the predefined output. The minimum positioning step only becomes active in modulating operation. For the external load controller via the analog input, a value of 1% is preset.

No.	Parameter
123.1	Minimum output positioning step: Output external load controller analog
204	Behavior if analog input is invalid (4...20 mA) 0 = default output low-fire / deactivate trim function (with warning message) 1 = safety shutdown + prevention of startup 2 = deactivate default output low-fire / trim function (without warning message)

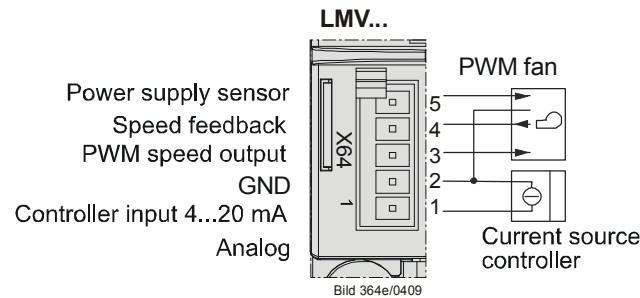

Figure 82: External load controller via analog input X64 pin 1 / X64 pin 2

10.5.1 Thresholds for modulating operation

Actual value	Current	Display / output value
Low-fire	3...4 mA	20%
Low-fire	4 mA	20%
High-fire	20 mA	100%

10.5.2 Switching thresholds for multistage operation

For multistage operation, a hysteresis band about the thresholds is provided. The hysteresis band replaces the minimum control step for multistage operation. The band width is approx. 1 mA.

2-stage operation

Actual value	Current	Display / output value
Stage 1	5 mA (3...12 mA)	P1
Hysteresis band	12...13 mA	---
Stage 2	15 mA (13...20 mA)	P2

3-stage operation

Actual value	Current	Display / output value
Stage 1	5 mA (3...7 mA)	P1
Hysteresis band 1	7...8 mA	---
Stage 2	10 mA (8...12 mA)	P2
Hysteresis band 2	12...13 mA	---
Stage 3	15 mA (13...20 mA)	P3

10.6 Prioritization of load controller sources

To simplify configuration of the system, the load controller source need not be selected. The LMV36 automatically detects the available load controller sources and selects them. If several sources are used, they are selected according to the following priorities:

Parameter 942	Priority	Active load controller source
	1 highest	Chapter <i>Load controller ON-contact X5-03, pin 1</i> When the input is activated, the other load controller sources are assessed according to their priorities. When the input is deactivated, the burner is off
1	2	Chapter <i>Load output with curve settings</i>
2	3	Chapter <i>Manual output</i>
3	4	Chapter <i>Load controller via the building automation system X92</i>
4	5 lowest	Chapter <i>External load controller via analog input X64 pin 1 / pin 2</i>

The active load controller source can be read out via parameter 942.

No.	Parameter
942	Active load source 1 = output during curve settings 2 = manual output 3 = default output via building automation 4 = default output via analog input 5 = external load controller via contacts

10.6.1 Emergency operation with several load controllers sources

By making use of the prioritization described above, it is also possible to implement emergency operation.

Should the building automation and control system fail (provided parameter 148 / 149 is set to undefined (--)), the LMV36 switches automatically over to the external load controller.

A load controller via analogue input or, if existing via contacts can be connected.

No.	Parameter
148	<p>Predefined output in the event of communication breakdown with building automation</p> <p>Setting values: For modulating operation, the setting range is as follows: 0...19.9 = burner off 20...100 = 20...100% burner output (20 = low-fire position)</p> <p>For multistage operation, use the following settings: 0 = burner OFF P1...P3 = stage 1...stage 3</p> <p>Invalid = no output predefined by the building automation system in the event of communication breakdown</p> <p>Default setting: <i>Invalid</i></p>
149	<p>Fuel 1: Predefined output in the event of communication breakdown with building automation</p> <p>Setting values: For modulating operation, the setting range is as follows: 0...19.9 = burner off 20...100 = 20...100% burner output (20 = low-fire position)</p> <p>For multistage operation, use the following settings: 0 = burner OFF P1...P3 = stage 1...stage 3</p> <p>Invalid = no output predefined by the building automation system in the event of communication breakdown</p> <p>Default setting: <i>Invalid</i></p>

11 Electronic fuel-air ratio control

11.1 General

Electronic air-fuel ratio control is used to control the burner's actuators depending on burner output. It is possible to connect 2 actuators and, optionally, 1 VSD. Resolution is 0.1° with the actuators and 0.1% with the VSD. Output can be regulated in increments of 0.1% in modulating mode or with a maximum of 3 stages in multistage mode.

To reduce the electric power required for the actuators, they are never operated simultaneously, but in successive order, or alternately.

11.2 Behavior outside the operating positions

Outside their operating positions, the actuators approach the different positions in successive order. The program phase determines the position to be approached.

11.2.1 Traveling speed

The running speed of the actuators is fixed at 5 seconds for a positioning angle of 90° for SQM33.4, SQM33.5, and SQN1.

The speed is 10 seconds for a positioning angle of 90° for SQM33.6.

The SQM33.7 requires 17 seconds for a positioning angle of 90°.

The ramp speed of the VSD can be adjusted separately for higher and lower speeds.

No.	Parameter
522	Ramp up
523	Ramp down

The setting also applies to the operating position (refer to chapter *Operating position*).

11.2.2 Home position

This position is approached in the *Home run* (10), *Standby* (12) and *Lockout position* (00) phases.

The position can be set via the following parameters:

Parameter	Actuator
501.00	Idle position fuel actuator
502.00	Idle position air actuator
503.00	Idle speed VSD
504.00	Fuel 1: Idle position fuel actuator
505.00	Fuel 1: Idle position air actuator
506.00	Fuel 1: Idle speed VSD

11.2.3 Prepurging

This position is approached in phase *Traveling to prepurging* (24).

The position can be set via the following parameters:

Parameter	Actuator
501.01	Prepurge position fuel actuator
502.01	Prepurge position air actuator
503.01	Prepurge speed VSD
504.01	Fuel 1: Prepurge position fuel actuator
505.01	Fuel 1: Prepurge position air actuator
506.01	Fuel 1: Prepurge speed VSD

No.	Parameter
222	Gas: Prepurging 0 = inactive 1 = active
262	Oil: Prepurging 0 = inactive 1 = active
322	Fuel 1 gas: Prepurging 0 = inactive 1 = active
362	Fuel 1 oil: Prepurging 0 = inactive 1 = active

11.2.4 Ignition

The ignition position is approached in phase *Traveling to the ignition position* (38).

The position is set via curve parameterization under **P0**. In modulating operation, this point is assigned to an output of 10%.

11.2.5 Postpurging

This position is approached in phase *Traveling to postpurging* (72).

The position can be set via the following parameters:

Parameter	Actuator
501.02	Postpurge position fuel actuator
502.02	Postpurge position air actuator
503.02	Postpurge speed VSD
504.02	Fuel 1: Postpurge position fuel actuator
505.02	Fuel 1: Postpurge position air actuator
506.02	Fuel 1: Postpurge speed VSD

11.3 Modulating operation

In modulating mode, it is possible to operate 2 actuators and 1 VSD. The burner's output can be regulated between 20.0% (low-fire) and 100.0% (high-fire) in increments of 0.1%. Since the actuators are never allowed to operate simultaneously, the output is increased in small steps of 1%.

With a ramp-up time of 32 seconds in operating position (from 20% to 100%), this results in a step within 400 ms.

Within such an output step, the air actuator or the VSD is operated in the first 200 ms, and the fuel actuator in the second 200 ms.

11.3.1 Definition of curves

The fuel-air ratio curves are defined by 10 curvepoints that are firmly distributed across the output range.

The following assignment applies:

Curvepoint	Output	Meaning
P0	10%	Point of ignition, not approached in the operating position
P1	20%	Low-fire
P2	30%	
P3	40%	
P4	50%	
P5	60%	
P6	70%	
P7	80%	
P8	90%	
P9	100%	High-fire

The actuator positions can be set with a resolution of 0.1°. Between the curvepoints, the positions are interpolated in a linear manner.

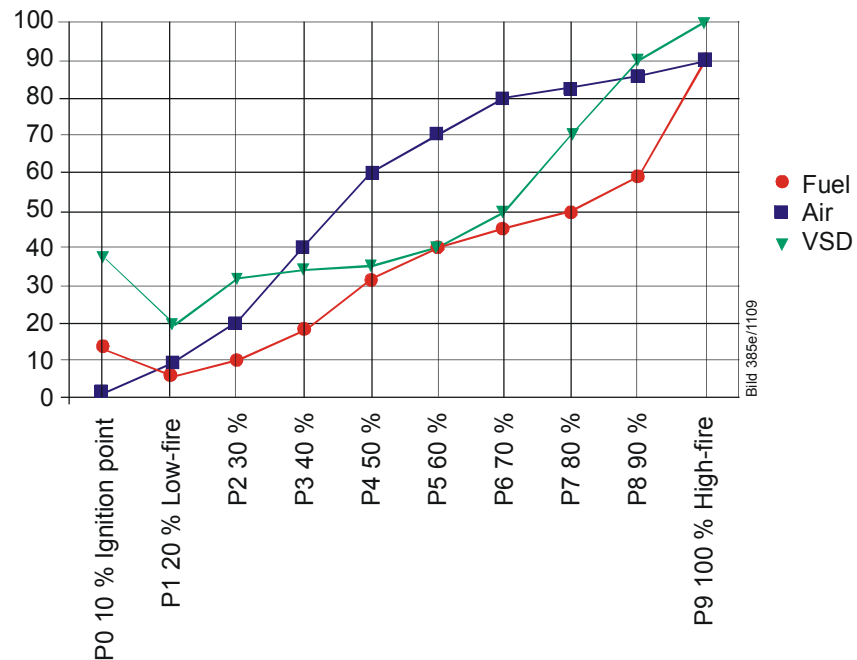

Figure 83: Definition of curves

No.	Parameter
401	Ratio control curve fuel actuator (curve setting only)
402	Ratio control curve air actuator (curve setting only)
403	Ratio control curve VSD (curve setting only)
404	Fuel 1: Ratio control curve fuel actuator (curve setting only)
405	Fuel 1: Ratio control curve air actuator (curve setting only)
406	Fuel 1: Ratio control curve VSD (curve setting only)

11.3.2 Traveling speed/maximum curve slope

The rise time required to modulate from low-fire to high-fire can be set via parameter 544.

The following maximum curve slopes (positioning angle) can be achieved depending on the set ramp-up time (parameter 544):

Type of actuator	Positioning speed	Modulation 32 s	Modulation 48 s	Modulation 64 s	Modulation 80 s
		Positioning angle ²⁾	Positioning angle ²⁾	Positioning angle ²⁾	Positioning angle ²⁾
Actuators (3 Nm)	5 s / 90°	31°	46°	62°	77°
Actuator SQM33.6	10 s / 90°	15°	22°	30°	37°
Actuator SQM33.7	17 s / 90°	9° 1)	13°	18°	22°
VSD	5 s / 100%	40 %	60 %	80 %	100 %
	10 s / 100%	20 %	30 %	40 %	50 %
	20 s / 100%	10 %	15 %	20 %	25 %
	30 s / 100%	6,6 % 1)	10 %	13 %	16 %
	40 s / 100%	5 % 1)	7.5 % 1)	10 %	12 %

¹⁾ Depending on the setting, the restriction of the maximum positioning angle does not permit the maximum position of 90° to be reached

²⁾ Maximum difference between 2 curve points

No.	Parameter
522	Ramp up
523	Ramp down
544	Ramp modulating
647	No-load time for speed measurement in modulating operation [25 ms]

The setting also acts outside the operating position (refer to chapter *Traveling speed*).

VSD / PWM fan

For the VSD or the PWM fan, it is also possible to change the maximum speed differential between 2 curvepoints via the no-load time for the speed measurement in modulating operation. This is 200 ms (value 8) in the default setting and can be reduced to 100 ms (value 4). Shortening the no-load time can result in problems in connection with the internal speed control of the LMV36 and is only recommended with the control deactivated.

The achievable maximum speed difference can be calculated based on the following formula:

$$\text{Maximum speed differential} = \frac{100\% * \text{modulating operating ramp} * (16 - \text{no-load time speed measurement})}{(\text{Ramp time} * 128)}$$

Between the ignition time (P0) and the low-fire point (P1), a speed differential of up to 40% can be set for the VSD or the PWM fan, independent of the selected ramp. This means that the period of time from ignition to low-fire can vary between 4...32 seconds (5...40 seconds ramp).

Error code	Diagnostic code	Meaning for the LMV36
84	Bit 0 Valency 1	VSD: Curve too steep in terms of ramp rate
	Bit 1 Valency 2...3	Fuel actuator: Curve too steep in terms of ramp rate
	Bit 2 Valency 4...7	Air actuator: Curve too steep in terms of ramp rate

The parameterized curve is steeper than permitted with the selected actuator speed.

11.3.3 Entering the running position

The burner is ignited when ignition position **P0** is reached. When entering operating phase **60**, the actuators follow the defined curves until the low-fire position is reached (20% or parameter 545 / 565).

No.	Parameter
545	Lower output limit undefined = 20 %
565	Fuel 1: Lower output limit undefined = 20 %

11.3.4 Operating position

As demanded by the load controller, the actuators are driven along the defined 20% and 100% curves. Point of ignition **P0** can only be reached via the curve settings.

11.3.5 Limitation of modulation range

If the modulation range shall be further restricted from 20 to 100% against the defined curve, 4 parameters are available to define a new low-fire and high-fire position.

No.	Parameter
545	Lower output limit undefined = 20 %
546	Upper output limit undefined = 100 %
565	Fuel 1: Lower output limit undefined = 20 %
566	Fuel 1: Upper output limit undefined = 100 %

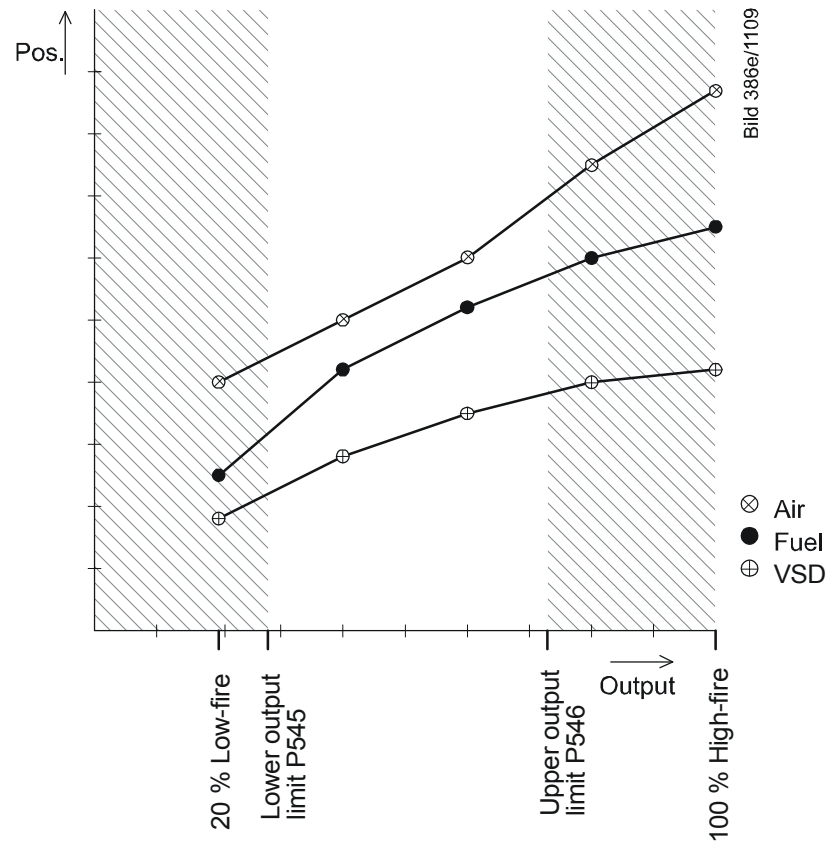

Figure 84: Restriction of modulation range

11.3.6 Setting the minimum and maximum output

For changes regarding setting of the minimum and maximum output after the curve settings, note the following:

After leaving the curve settings with completely defined curvepoints, proceed in modulating operation by setting the minimum / maximum output (parameters 546 / 545 or 566 / 565).

In case of the warm setting, the parameterized output remains active until setting of the minimum / maximum output is completed. Any change to the minimum / maximum output is included in the parameterized output.

Automatic operation is only activated once the minimum/maximum output setting is exited.

As a result of this procedure, the LMV36 maintains the output set by the user, thus ensuring **trouble-free** setting of the minimum / maximum output.

Advantages:

- The actual output always corresponds to the currently parameterized minimum / maximum output or the system output resulting from the curve setting made last, which means that the output can be ascertained accurately and without interference
- The load controller sources of low priority (contacts, analog input, building automation system output, manual output) are inactive
- During the curve and the subsequent minimum/maximum output settings, the *Manual OFF* function is deactivated
- Unambiguous and easy-to-understand behavior of the system



Note

If output limitation is not required, the minimum / maximum output need **not** be set. In that case, an undefined minimum / maximum output corresponds to a minimum output of 20% and a maximum output of 100%.

No.	Parameter
545	Lower output limit undefined = 20%
546	Upper output limit undefined = 100%
565	Fuel 1: Lower output limit undefined = 20%
566	Fuel 1: Upper output limit undefined = 100%

11.4 Multistage operation

This operating mode is only available when firing on oil. There is a choice of 2-stage and 3-stage operation. Hence, the burner's output can be modulated via 2 or 3 stages. Modulation is accomplished by adjustment of the air actuator or the VSD and by switching the fuel valves for adjusting the amount of fuel.

11.4.1 Definition of curves

Fuel-air ratio control is defined via the 2 or 3 static output points. To switch the valves on and off, switch-on and switch-off points must be defined.

The following assignments apply:

Curve-point	Meaning	Valve
P0	Point of ignition (not approached in the operating position)	V1
P1	Stage 1	V1
P2on	Switch-on point stage 2. When the angle exceeds this point, the fuel valve for the second stage is switched on	V1
P2_d	Presetting of point P2 with no approach	V1
P2	Stage 2	V2
P2of	Switch-off point stage 2. When the angle falls below this point, the fuel valve for the second stage is switched off	V2
P3on	Switch-on point stage 3. When the angle exceeds this point, the fuel valve for the third stage is switched on	V2
P3_d	Presetting of point P3 with no approach	V2
P3	Stage 3	V3
P3of	Switch-off point stage 3. When the angle falls below this point, the fuel valve for the third stage is switched off	V3

The actuator positions can be set with a resolution of 0.1°, the speeds with a resolution of 0.1%.

11.4.2 Traveling speed

The defined ramp speeds are used.

The speed of the VSD can be adjusted separately for speed increase or decrease.

No.	Parameter
522	Ramp up
523	Ramp down

The setting also acts outside the operating position.

The running speed of the actuators is fixed at 5 seconds for a positioning angle of 90° for SQM33.4, SQM33.5, and SQN1. The speed is 10 seconds for a positioning angle of 90° for SQM33.6. The SQM33.7 requires 17 seconds for a positioning angle of 90°.

11.4.3 Adjustment of output

When the output increases, the LMV36 moves from the curvepoint of stage 1 (P1) to the switch-on point of stage 2 (P2on). If the switch-on point is exceeded, the valve for the second stage is switched on. Then, the LMV36 moves to the curvepoint for stage 2 (P2). When the output decreases, the LMV36 moves from the curvepoint of stage 2 (P2) to the switch-off point of stage 2 (P2of). If this point is crossed, the valve for the second stage is switched off. Then, the LMV36 moves to the curvepoint for stage 1 (P1). In 3-stage operation, the output between stage 2 and stage 3 is adjusted analogously to 2-stage operation. As static outputs, only **P1**, **P2** and **P3** can be approached. The switch-on and switch-off points are crossed only when changing between stages. The traveling speeds are fixed. Depending on the positioning angles to be covered, air actuator and VSD do not reach the operating or switch-on/switch-off points at the same time. The valves are switched on / off only after the actuators have reached their correct positions.

When parameterizing the curves, the switch-on points can also be approached in a stationary manner. In addition, when setting the curve via $P2_d$ ($P3_d$), curvepoint $P2$ ($P3$) can be readjusted without traveling to it. In that case, the LMV36 is at the respective switch-on point. This procedure is used to reduce the operating time if there is shortage of air.

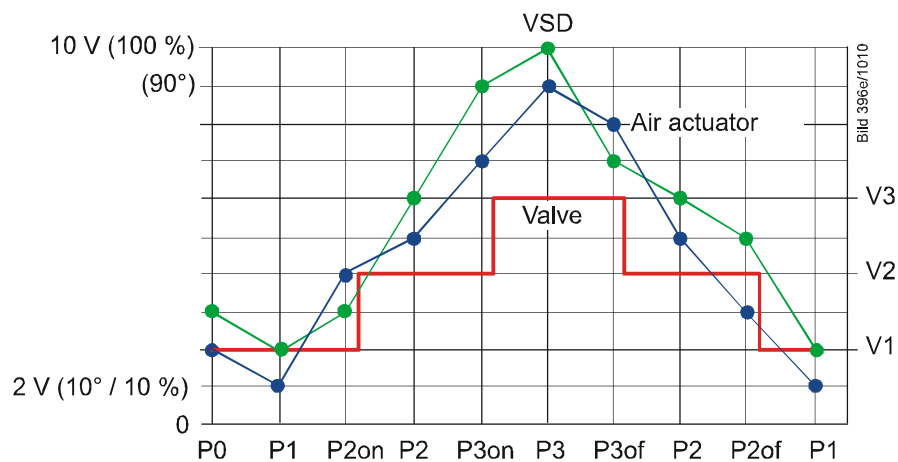

Figure 85: Adjustment of output

11.4.4 Entering the operating position

The burner is ignited at ignition position **P0**. When entering operating phase **60**, the actuators are driven from ignition position **P0** to the operating point of stage 1 (P1) at the respective traveling speed.

11.4.5 Operating position

In the operating position, the burner's output can be adjusted between operating points **P1** and **P2** or **P3** in accordance with the load controller's presetting, as described in chapter *Adjustment of output*. Ignition position **P0** is not approached anymore. It can only be reached via curve adjustment.

11.4.6 Limitation of modulation range

If the modulation range for stage 1 and stage 2, or stage 3, shall be further restricted, 4 parameters can be used to define a new low-fire and high-fire position.

No.	Parameter
545	Lower output limit undefined = 20 %
546	Upper output limit undefined = 100 %
565	Fuel 1: Lower output limit undefined = 20 %
566	Fuel 1: Upper output limit undefined = 100 %

11.5 End of operating position

When there is no more heat request, the LMV36 switches to phase 62. Here, the burner runs down to low-fire as long as possible before the valves are shut.

The available period of time can be set via parameter 212. If this time is set to the minimum value, the burner is immediately shut down if there is no more request for heat. If the time exceeds 32 seconds, the burner always runs to low-fire. Naturally, it is also possible to set intermediate times.

No.	Parameter
212	Maximum time down to low-fire

11.6 Notes on settings and parameter settings

- When making the settings for the electronic fuel-air ratio control system integrated in the LMV36, it must be ensured that sufficient amounts of excess air are available because over a period of time, the flue gas values are impacted by a number of factors, such as air density, wear of actuators and controlling elements, etc. For this reason, the flue gas values initially set must be checked at regular intervals
- To safeguard against accidental or unauthorized transfer of parameters from the parameter backup of the ACS410 to the LMV36, the OEM (burner or boiler manufacturer) must enter an **individual burner identification** for every burner. Only when this requirement is satisfied does the LMV36 make certain that the ACS410 does not transfer a parameter set from a plant (with unsuited and possibly dangerous parameter values) to the LMV36
- With the LMV36, it should be noted that the unit's characteristics are determined primarily by the parameter settings and not so much by the type of LMV36. This means that – among other considerations – the parameter settings must always be checked prior to commissioning the plant, and that the LMV36 must never be transferred from one plant to another without adapting its parameters to the new plant
- When using the ACS410 PC software, the safety notes given in the relevant Operating Instructions (J7352) must also be observed
- The parameter level is password-protected. The OEM assigns individual passwords to the parameter levels he can access. The unit is supplied with default passwords entered by Siemens; they must be changed by the OEM. These passwords are confidential and may be assigned to authorized personnel only
- The responsibility for setting parameters is assumed by the person who, in accordance with the access rights, has made changes on the respective setting level

In particular, the OEM assumes responsibility for the correct parameter settings in compliance with the standards covering the specific applications (e.g. EN 676, EN 267, EN 1643, etc.).

12 Actuators X53 / X54

One or 2 actuators can be connected to the LMV36, depending on the selected operating mode (refer to chapter *Selection of operating mode*).



Caution!

When mounting the actuators, it must be made certain that the mechanical link to the controlling elements is form-fitted!

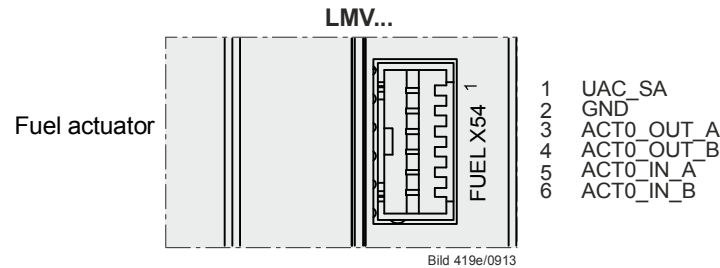

Figure 86: Fuel actuator (X54)

When using 2 actuators per fuel, they must be connected to the AGM60 (refer to chapter *AGM60*). Otherwise, the fuel actuator must be connected directly to the LMV36.

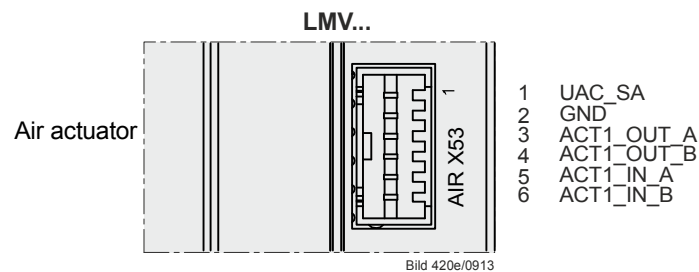

Figure 87: Air actuator (X53)

12.1 Function principle

The actuators are driven by stepper motors. The resolution reached when making 1 positioning step is 0.1° .

The running speed of the actuators is fixed at 5 seconds for a positioning angle of 90° for SQM33.4, SQM33.5, and SQN1.

The speed is 10 seconds for a positioning angle of 90° for SQM33.6.

The SQM33.7 requires 17 seconds for a positioning angle of 90° . An optical incremental transducer is used to monitor the current position. Due to the use of a gear train with almost no backlash, position control is not required.

12.2 Definition of angles

The angles and angular ranges are specified in the Data Sheets of the relevant actuators.

SQM33.4: Refer to Data Sheet N7813.

SQN1: Refer to Data Sheet N7803.

Also refer to figure *Angle definitions with SQM33*.

12.3 Referencing

An incremental transducer is used for position feedback. This means that referencing of the actuators must be performed after power-ON. In addition, at the end of each shutdown in phase 10, the actuators are referenced to ensure that individual stepping errors, which could lead to shutdown, do not accumulate. If a position error occurs, the LMV36 switches to the safety phase (phase 01), enabling the actuators with detected position errors to be referenced. During the following phase 10, the only actuators referenced are those that were not referenced before in the safety phase (phase 01). The position of the reference point can be selected depending on the type of burner, either the *Closed* position ($<0^\circ$) or the *Open* position ($>90^\circ$). When using actuators SQM33.6 or SQM33.7, the actuator type (parameter 613) must be set (refer to chapter *Actuator type / running time*).



Note!

If a SQM33.7 is used, the modulating operating ramp (parameter 544) may need to be increased (refer to chapter *Running speed / maximum curve slope*).

Listed below settings for air apply to both fuels:

- In single-fuel operation or in dual-fuel operation, the parameters 601...606 and 611 are assigned to fuel 0
- In dual-fuel operation, the parameters 608...610 and 612 are assigned to fuel 1

No.	Parameter
544	Ramp modulating
601	Selection of reference point Index 0 = fuel Index 1 = air Setting values: 0 = closed ($<0^\circ$) 1 = open ($>90^\circ$)
602	Actuator's direction of rotation Index 0 = fuel Index 1 = air Setting values: 0 = counterclockwise 1 = clockwise (exclusively for SQM3)
606	Tolerance limit of position monitoring (0.1°) Index 0 = fuel Index 1 = air Greatest position error where an error is securely detected → error detection band: (parameter 606 -0.6°) up to parameter 606
608	Fuel 1: Selection of reference point for fuel actuator 0 = closed ($<0^\circ$) 1 = open ($>90^\circ$)
609	Fuel 1: Fuel actuator's direction of rotation 0 = counterclockwise 1 = clockwise (exclusively for SQM3)
610	Fuel 1: Tolerance limit of position monitoring (0.1°) for fuel actuator Greatest position error where an error is securely detected → Error detection band: (parameter 606 -0.6°) up to parameter 606
611	Type of reference Index 0 = fuel Index 1 = air Setting values:

No.	Parameter
	0 = standard 1 = range stop in the usable range 2 = internal range stop (SQN1) 3 = both
612	Fuel 1: Type of reference for fuel actuator 0 = standard 1 = range stop in the usable range 2 = internal range stop (SQN1) 3 = both
613	Type of actuator Index 0 = fuel Index 1 = air Setting values: 0 = 5 s / 90° (1 Nm, 1,2 Nm, 3 Nm) 1 = 10 s / 90° (6 Nm) 2 = 17 s / 90° (10 Nm)
614	Fuel 1: Actuator type of the fuel 0 = 5 s / 90° (1 Nm, 1,2 Nm, 3 Nm) 1 = 10 s / 90° (6 Nm) 2 = 17 s / 90° (10 Nm)



Application note!

Single-sided load torque is recommended due to the type of gear train for the SQM33.6 / SQM33.7 actuators. In the event of load on both sides, a backlash of $\pm 0.3^\circ$ must also be considered in addition to plant design or setting

12.3.1 Reference run

Different reference runs are made to unambiguously determine the actuators' permissible working range. This means that, in the event of a power failure during referencing, the actuator is prevented from travelling to a range outside the optical feedback system or from running against a mechanical stop. Parameters 611 and 612 must be set, depending on the mechanical design and the type of actuator used. In the case of reference travel type 1 the SQM33 actuator first travels to the starting point.



Note!

Always select reference travel type 2 for SQN13 and SQN14.

Parameterization for reference travel type 0 and type 2

No.	Parameter	Setting for actuator		
		SQM33	SQN13	SQN14
611	Type of referencing			
	Index 0 = fuel	0	2	2
	Index 1 = air	0	2	2
612	Fuel 1: Type of referencing for fuel actuator	0	2	2

Parameterization for reference travel type 1

No.	Parameter	Setting for actuator		
		SQM33		
611	Type of referencing			
	Index 0 = fuel	1		
	Index 1 = air	1		
612	Fuel 1: Type of referencing for fuel actuator	1		

To prevent the actuator from running against a mechanical stop during referencing, the home position may have to be adjusted (depending on the direction of rotation and a reference point of about 3° or 87°). In the case of stops within the usable range, the prepurge or postpurge position must be checked also.

Refer to the figure below for details of the reference travel.

Example of actuator with counterclockwise rotation:

When referencing in the CLOSED position, the actuator first travels a certain distance into the working range (toward the OPEN position). Then, it travels to a position representing maximum -7.7° , thereby crossing the reference mark for the first time. Then, the actuator moves in the other direction again and detects the inner ramp of the reference mark. This is the reference point used by all positions. If the reference point is parameterized in the OPEN position, referencing takes place in a mirror-symmetrical manner. In that case, the actuator first travels into the working range (toward the OPEN position). Then, it crosses the reference mark and travels to a position representing maximum 110.6° , then back to the inner ramp of the reference mark.

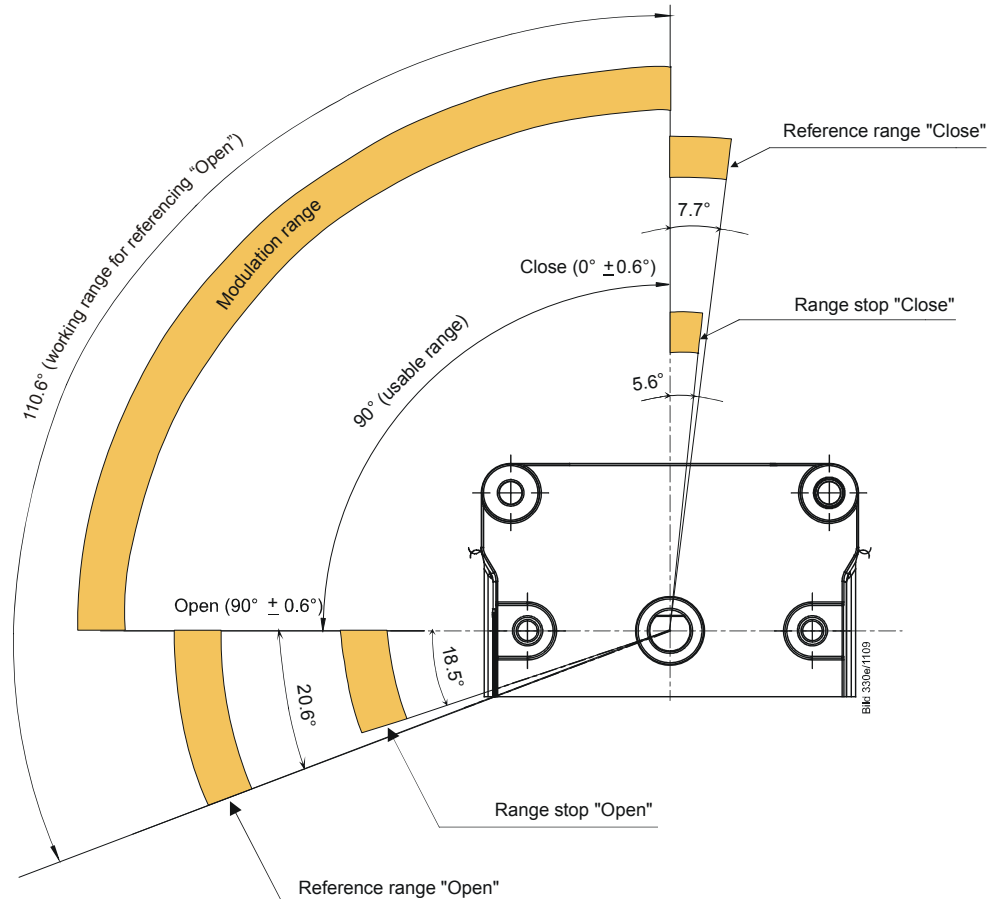

Figure 88: Angle definitions with SQM33

Error code	Diagnostic code	Meaning for the LMV36
85	0	Referencing error of fuel actuator
	1	Referencing error of air actuator
	Bit 7 Valency ≥ 128	Referencing error due to parameter change

12.4 Direction of rotation

With the SQM3 actuator, the direction of rotation can be selected on an individual basis.

No.	Parameter
602.00	Actuator's direction of rotation Index 0 = fuel Setting values: 0 = counterclockwise 1 = clockwise (exclusively for SQM3)
602.01	Actuator's direction of rotation Index 1 = air Setting values: 0 = counterclockwise 1 = clockwise (exclusively for SQM3)
609.00	Fuel 1: Fuel actuator's direction of rotation 0 = counterclockwise

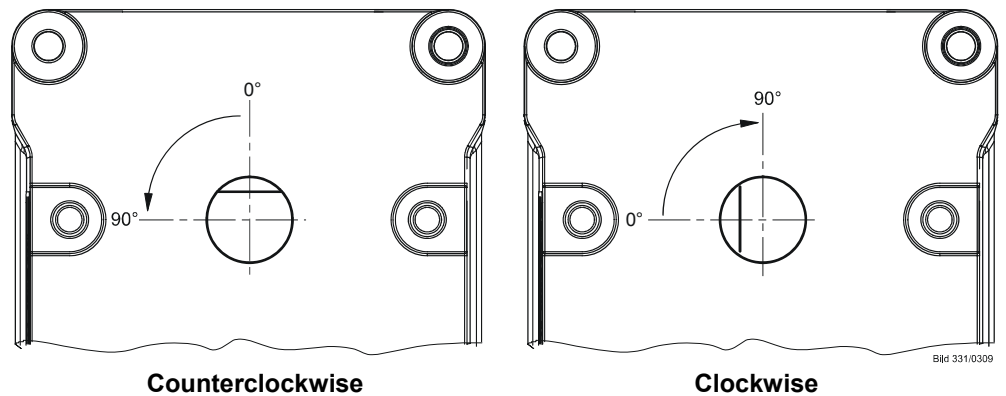

Figure 89: Direction of rotation (example SQM3)

The direction of rotation of the SQN1 actuators depends on the version:

- SQN13: Direction of rotation *Left*
- SQN14: Direction of rotation *Right*



Note
The actuators are always supplied with the flat of the drive shaft facing upward.

12.5 Monitoring the actuator positions

To monitor the actuator's current positions, an optical incremental transducer with a resolution of 0.7° is used. The correct position of the drive shaft is ensured by comparing the motor steps made with the position obtained from the incremental transducer. Due to the different resolutions of motor steps and incremental transducer plus the selected tolerance band, the following error detection band is obtained. The position where – in the error detection band – shutdown takes place depends on the position currently required.

For the default setting made in the factory, the error detection band is as follows:

Smallest position error where an error can be detected	0.8°
Greatest position error where an error is securely detected (default setting parameter 606 or 610)	1.7°

The presetting of 1.7° (default setting, parameter 606 or 610) is suited for use with actuators type SQN1 and SQM3.



Note

When using SQN1 actuators equipped with plastic gear trains, we recommend to change the preset values as follows:

Product no.	Value
SQN13.14	1,7°
SQN14.14	1,7°
SQN13.17	2,2°
SQN14.17	2,2°

When referencing under output conditions, the resilience of the actuator's gear train must also be taken into consideration:

Product no.	Resilience at max. rated driving torque
SQM33.41	0.2°
SQM33.51	0.2°
SQM33.6	0.2°
SQM33.7	0.2°
SQN13.14	0.3°
SQN13.17	0.8°
SQN14.14	0.3°
SQN14.17	0.8°

The error detection time is <1 second.



Caution!

This means that – for the design and setting of the burner – a position error resulting from the sum of ...

- greatest position error from which an error is detected in all positions,
- resilience at the max. rated torque, and
- mechanical influence from the link between actuator and regulating unit (e.g. coupling)

must not lead to a critical state in terms of safety.

No.	Parameter
606	<p>Tolerance limit of position monitoring (0.1°) Index 0 = fuel Index 1 = air</p> <p>Greatest position error where an error is securely detected → error detection band: (parameter 606 -0.6°) up to parameter 606</p>
610	<p>Fuel 1: Tolerance limit of position monitoring (0.1°) for fuel actuator</p> <p>Greatest position error where an error is securely detected → error detection band: (parameter 606 -0.6°) up to parameter 606</p>

Error code	Diagnostic code	Meaning for the LMV36
86	0	Fuel actuator: Position error
87	0	Air actuator: Position error

12.6 Changing the error detection band for monitoring the actuator positions

The error detection band can be changed via parameter 606 or 610. A change is to be made only when using SQN13.17 or SQN14.17 actuators which, due to their mechanical design, require greater tolerances. For these types of actuators, set parameter 606 or 610 to 2.2°.

No.	Parameter
606	Tolerance limit of position monitoring (0.1°) Index 0 = fuel Index 1 = air Greatest position error where an error is securely detected → Error detection band: (parameter 606 -0.6°) up to parameter 606
610	Fuel 1: Tolerance limit of position monitoring (0.1°) for fuel actuator Greatest position error where an error is securely detected → Error detection band: (parameter 606 -0.6°) up to parameter 606

12.7 Forced travel

There are errors in the actuators' feedback unit which can only be detected in connection with position changes. To be able to also detect such errors when maintaining the same position for longer periods of time, travel is enforced when, for more than 50 minutes, an actuator moves no more than 2.8°. With forced travel, both actuators are driven 2.8° in the direction of smaller positioning angles and back again to the initial angular position. If a damper is less than 2.8° open, the actuator is driven in the direction of positive angles in order not to run against mechanical stops, if present. Forced travel lasts a total of 1 second.

12.8 Detection of line interruptions

The connecting line ensuring position feedback from the actuator to the LMV36 is monitored for interruptions, which means that position feedback cannot fail without being noticed.

Error code	Diagnostic code	Meaning for the LMV36
86	Bit 0 Valency 1	Line interruption fuel actuator
87	Bit 0 Valency 1	Line interruption air actuator

12.9 Protection against mixup of actuator

Mixup of actuators can be detected through appropriate installation (using different reference marks for the air and fuel actuator: OPEN / CLOSED / 0° / 90°). With at least one of the actuators, the reference mark not used must be blocked by a mechanical stop. Now, if the actuator connections with the LMV36 have been interchanged, one of the actuators cannot reach the reference mark, which is detected by the LMV36. Protection against mixup is a question of burner application and must be ensured by the OEM.



Caution!

To be able to detect mixup of actuators, the burner manufacturer must ensure that the 2 actuators use opposing reference points. One of the actuators uses the OPEN reference, the other the CLOSED reference. Approach of the reference point not used must be blocked with at least one of the actuators!

12.9.1 Proposal for implementation

- Parameterize referencing of the air damper in the CLOSED position
- Parameterize referencing of the fuel damper in the OPEN position. Unnecessary travel can be avoided by defining a home position of **90°** for the fuel damper
- Mechanical stop at the air damper in the range between 90° and 108.5°, and / or mechanical stop at the fuel damper in the range between 0° and -5.6°

Referencing process

- From any position in the working range (0...90°), but typically from the home position, the air damper travels to the **-7.7°** position and back again to the home position
- From any position in the working range (0...90°), but typically from the home position, the fuel damper travels to the **110.6°** position and back again to the home position

Action in the event of mixup

- The fuel damper (fitted in place of the air damper) travels to the **-7.7°** position and back again to the home position
- The air damper (fitted in place of the gas damper) tries to travel to the **110.6°** position, but is prevented from doing so by the mechanical stop. This is unsuccessful travel and identified as mixup

The above procedure to prevent mixup of actuators by using different reference positions is only suited for 2 actuators. In the case of dual-fuel systems with 3 actuators, it can be employed to prevent mixup of air actuator and fuel actuators OR to prevent mixup of fuel actuators. With the LMV36, the above procedure ensures protection against mixup of air actuator and fuel actuators (different reference positions and mechanical stops).



Note

It is recommended to color-code the actuators' assignment to the AGM60, thus preventing mixup of actuators by observing the respective color marks on the AGM60 and the actuators' connectors.

Alternatively, protection against mixup of one of the fuel actuators can also be ensured by a coding pin on the AGM60.

13 Fan control

13.1 Function principle

Optionally, the LMV36 can be operated with a VSD or PWM fan.
 The activation takes place via a DC 0...10 V or alternatively via a PWM interface.
 For control of the fan's speed, a safety-related speed feedback signal is required.
 With pneumatic ratio control, the speed feedback signal is not evaluated as standard.
 It is, however, possible to define additional limit thresholds for supervising the fan speed during prepurging, ignition and operation.
 To facilitate the use of fans with different speed ranges, the fan's speed is standardized between 0...100% (up to 14000 rpm is supported as the maximum fan speed).
 If fan control is not connected, a load output and, alternatively, a fuel meter output are available (refer to chapters *Load output X74 pin 3* and *Fuel meter input X75 pin 1 / X75 pin 2*).

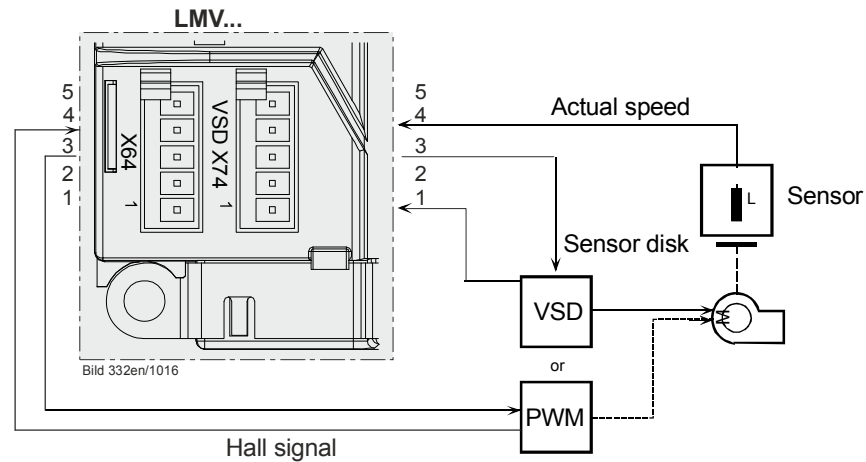

Figure 90: Function principle of fan control

13.2 Activation of VSD/PWM fan

The VSD can be activated in any of the operating modes (parameters 201 and 301).

No.	Parameter
542	Activation of VSD / PWM fan 0 = deactivated 1 = activated 2 = activated (no repetition)



Note

For configuration of the analog output when the VSD is activated, refer to chapter *Power output X74 pin 3!*

13.3 VSD control X74 pin 3

The VSD is controlled via a voltage interface (refer to chapter *Load output X74 pin 3*)!

Depending on the type of VSD used, a release contact is required. This contact can be controlled via the fan motor contactor. To enable the VSD to bring the fan motor's speed to the correct no-load speed, the motor contactor's drop out delay time must be about 25 seconds.

Example:

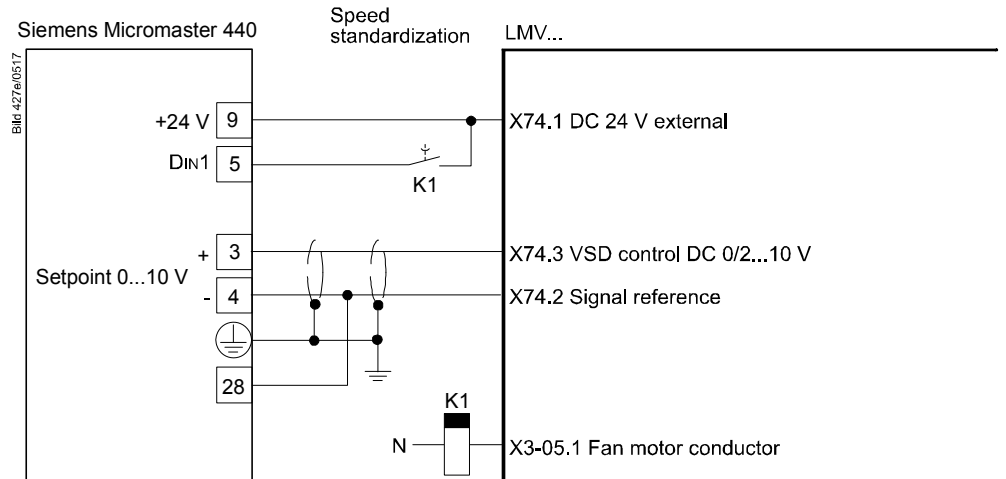

Figure 91: Connection of VSD to the LMV36

It is possible to set the VSD control to 0 via the analog output when the safety loop is open (including burner flange switch). This may be necessary if the no-load speed is not 0.

No.	Parameter
652	VSD behavior when safety loop / burner flange is open 0 = no VSD control when safety loop / burner flange is open 1 = VSD control independent of safety loop / burner flange

13.4 PWM fan control X64 pin 3

The PWM fan is controlled via PWM voltage interface X64 pin 3.



Caution!

A PWM fan can only be used in the factory settings in conjunction with pneumatic ratio control!

A PWM fan motor can only be used in the electronic ratio control system with a self-regulated PWM fan (see chapter *Speed control*).

13.5 Safe separation of mains voltage and protective extra low-voltage



Caution!

All inputs and outputs of PWM fan control are designed for use with protective extra low-voltage. For this reason, strict separation from the mains voltage side must be ensured!

This necessitates an external power supply by the VSD or an external power pack (X74 pin 1, X74 pin 2).

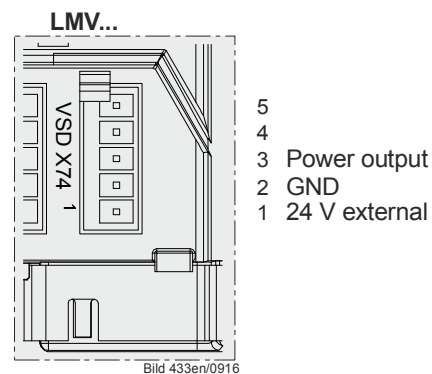

Figure 92: Power output



Note

Power must also be supplied via X74 pin 1 / pin 2 in the case a PWM fan is used.

13.6 Ramp time

The ramp time for fan control can be set separately for acceleration and deceleration (also refer to chapter *Traveling speed/maximum curve slope*).

No.	Parameter
522	Ramp up
523	Ramp down
544	Ramp modulating

If shutdown occurs because the speed has not been reached, the VSD/fan motor might not be able to follow quickly enough the set ramp.

In the case of a ramp time >20 seconds, the modulating operating ramp (parameter 544) must be increased (refer to chapter *Running speed / maximum curve slope*).

Remedy:

Shorten further the ramp of the VSD/fan motor or increase the ramp in the LMV36 (parameters 522/523) (also refer to chapter *Traveling speed/maximum curve slope*).

For VSD operation



Caution!

The ramps parameterized for the VSD should be at least 20% shorter than the ramps in the LMV36.

Example:

5 s ramp	LMV36 4 s ramp VSD
10 s ramp	LMV36 8 s ramp VSD
20 s ramp	LMV36 16 s ramp VSD
40 s ramp	LMV36 32 s ramp VSD

13.7 Acquisition of speed

13.7.1 Acquisition of speed with proximity switch

The actual speed is acquired by an inductive proximity switch which scans a metal sensor disk. The sensor disk must be attached directly to the motor's drive shaft. Speed acquisition is safety-related. To facilitate the detection of the direction of rotation and to be able to make the plausibility check with only 1 sensor, a sensor disk with angular steps of 60°, 120° and 180° is used. It generates 3 pulse intervals of different length.

Speed acquisition is designed for the connection of different types of sensors.



Caution!

With electronic fuel-air ratio control, speed acquisition is safety-related!

We recommend using the AGG5.310 accessory set.

The absolute speed can be read out via the AZL2.

No.	Parameter
935	Absolute speed

The current speed in standardized form can be read out via the AZL2.

No.	Parameter
936	Standardized speed

Speed input X74 pin 4

Motor speed:	300...14000 rpm
100% speed:	650...14000 rpm
Sensor:	Inductive sensor to DIN 19234 (Namur) or Open Collector (pnp) at $U_{CEsat} < 4\text{ V}$, $U_{CEmin} > DC\ 15\text{ V}$
Power supply:	DC 10 V, max. 15 mA
Switching current:	>10 mA
Cable length:	Max. 3 m (sensor cable must be laid separately!)

Sensor disk

Sensor disk and speed sensor can be ordered as accessory set AGG5.310.

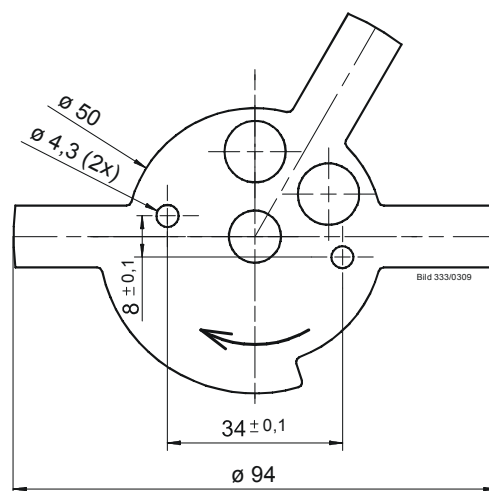

Number of tappets:	3
Angular steps:	60°, 120°, 180°
Accuracy:	±2°

Figure 93: Sensor disk

Speed sensor

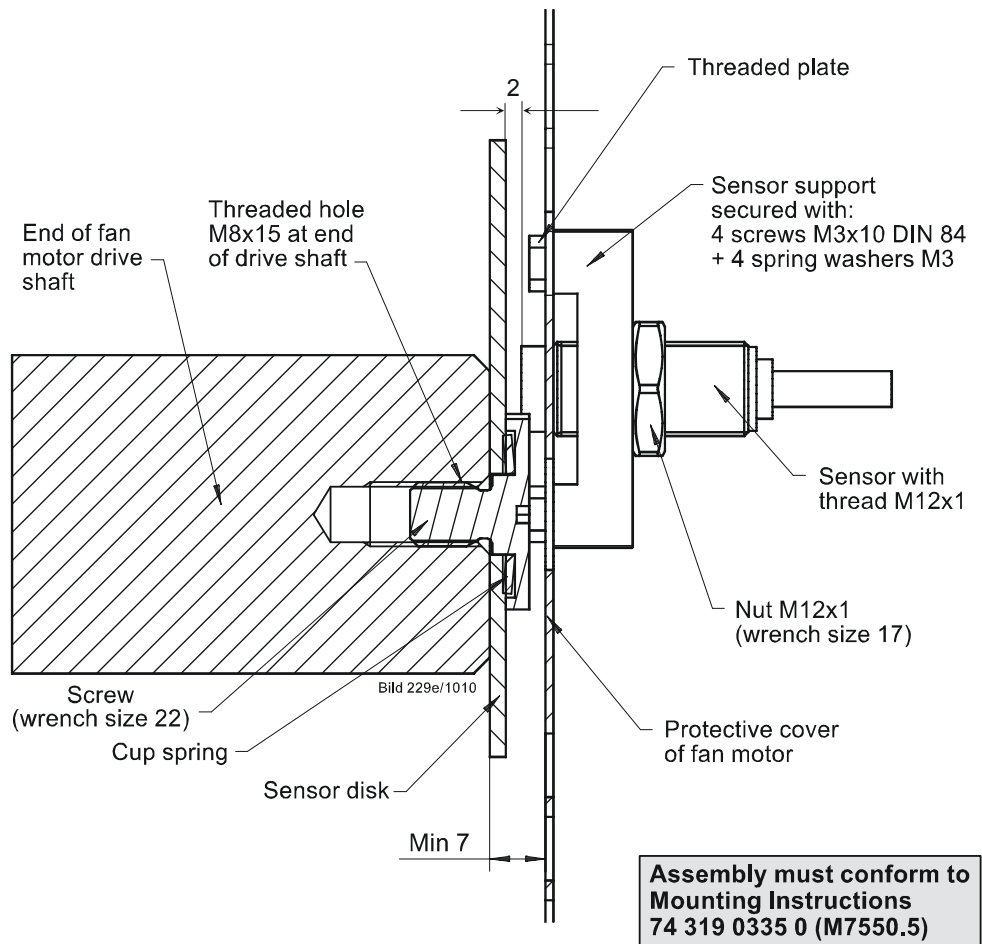

Figure 94: Speed sensor

Selection of fan motor

Motor supplier:

Selection of a motor **with** threaded hole M8 x 15 at the end of the fan motor's drive shaft.

Standard motor and machining (drilling hole and cutting thread M8 x 15).

13.7.2 Acquisition of speed with Hall generator

If the speed is acquired via a Hall generator, the requirements for safety-related applications are the same as those for the speed feedback signal via sensor disk. Required is an asymmetric signal with the 3 pulses of 60°, 120° and 180° for detection of the direction of rotation.

With the PWM fan, the symmetrical hall signal of the fan can also be used for the acquisition of motor speed. The symmetry and the number of pulses must be adapted for this. The maximum speed is 14000 rpm.

No.	Parameter
643	Setting speed signal 0 = asymmetrical 1 = symmetrical
644	Number of pulses per rotation (1 to 6)

13.7.3 Forced travel fan

When a symmetrical speed signal is used, like with the actuators, a forced travel is also carried out for the fan to detect an error in the speed feedback signal when a speed is maintained for a long period of time. The activation of the forced movement is started if the fan has not moved by more than the neutral zone of the speed supervision (parameter 662) for longer than 50 minutes.

During the forced movement, the fan travels 1.8% towards the lower speed and back to the original speed. If the start speed is lower than 11.8%, the fan speed is increased to prevent a drop below the minimum speed specification. The entire forced travel lasts approx. 1-2 seconds.

All relevant actuators are always moved during the forced travel, which means that, when the forced travel is actuated due to insufficient change in speed, the active actuators are also subjected to a forced travel or vice versa. This procedure reduces the frequency of the forced travel of the LMV36, as all actuators are processed synchronously.

No.	Parameter
662	Neutral zone of the speed supervision

13.8 Speed control

The LMV36 controls the fan motor's speed to the setpoint. To ensure that the speed can still be increased when the maximum speed is reached, the speed is standardized when the motor is controlled at 95%. Hence, with a speed setpoint of 100%, a speed increase of 5% is still possible.

The control range of the LMV36 is +15% / -10%. If this range is not sufficient, error 80 or 83 can occur.

Error code	Diagnostic code	Meaning for the LMV36
80	1	Control range limitation at the bottom
	2	Control range limitation at the top



Note

Internal control with a VSD or PWM fan motor must not be activated. Otherwise, speed variations can occur, resulting from simultaneous control actions from both the LMV36 and internal control.

The internal control of the LMV36 can be deactivated via parameters. On the one hand, this takes place automatically if a pneumatic operating mode is selected (see chapter *Selection of operating mode*). This is also necessary when a self-regulated PWM fan is used in an electronic ratio control system.

The speed control setting also has an impact on the determination of the standardized speed (see chapter *Speed standardization*).

No.	Parameter
661	LMV36 internal speed control
	0 = deactivated (self-regulated PWM fan)
	1 = activated (VSD)

13.9 Speed supervision

The fan's current speed is acquired by the LMV36 and assessed from a safety point of view. If the fan does not operate at the speed setpoint, speed control makes a corrective action, trying to reach the setpoint. If it is not reached within a certain period of time, safety shutdown is initiated. To ensure a high level of availability and safety, a number of monitoring bands with different response times are defined.

To adapt to the application, the tolerance bands and response or shutdown times can be changed via the OEM level in defined limits:

Tolerance band	Adjustable value range	Adjustment of the shutdown time
0...Neutral zone	Neutral zone (0.5...3.5%)	∞
Neutral zone...Close range	Close range (2...5.5%)	<8...16 s
> close range		<3...7 s

The combination of tolerance band and shutdown time must be chosen by the OEM so that no hazard potential can occur within the application.

No.	Parameter
662	Neutral zone of the speed supervision
663	Close range of the speed supervision
664	Speed supervision: Maximum time between the neutral zone and close range
665	Speed supervision: Maximum time outside close range

It is possible to switch off speed supervision at standstill (no-load speed 0%) in standby mode. This may be necessary if the fan rotates too much in standby mode due to a chimney draft or if an extended ramp time is active with a PWM fan during the transition from the postpurge speed to standstill.

No.	Parameter
653	VSD standstill supervision in standby mode 0 = deactivate 1 = active

The following tolerance bands and shutdown times apply in the default setting:

Speed deviation in % points	Shutdown time
0...0.5%	Speed reached → no shutdown
0.6...2%	<8 s
2.1...10%	<3 s
>10%	<1 s

13.9.1 Extended speed supervision

Additional supervision limits can be activated via the OEM level for different operating states. A check is only carried out to determine whether the value was exceeded or fallen short of here. A shutdown takes place after the *Maximum time outside close range* (parameter 665, default setting 3 s) has elapsed. An interruption in the speed feedback signal results in a safety shutdown within 1 second.

These limits can also be activated in pneumatic operation if a speed signal is present.

No.	Parameter
226	Gas: Preignition time
266	Oil: Preignition time
326	Fuel 1 gas: Preignition time
366	Fuel 1 oil: Preignition time
665	Speed supervision: Maximum time outside close range
667	Minimum prepurge speed
668	Maximum ignition speed
669.0	Minimum / maximum speed limitation in operation Index 0 = minimum speed
669.1	Minimum / maximum speed limitation in operation Index 1 = maximum speed

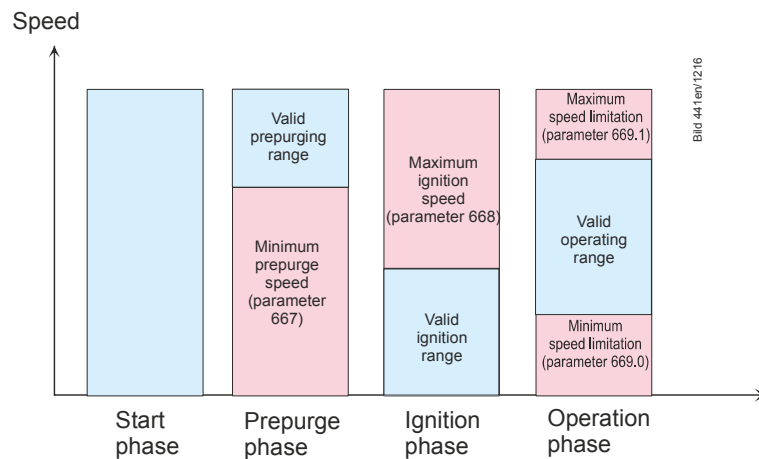

Figure 95: Extended speed supervision



Note!

- The standardization in pneumatic operation is only possible if at least one extended speed supervision has been activated (parameter 667, 668 or 669.0 / 669.1). The supervisory functions are deactivated in the presetting
- When supervising the maximum ignition speed, the preignition time (parameter 226 / 326 or 266 / 366) must correspond to at least the time setting *Maximum time outside close range* (parameter 665)

Error code	Diagnostic code	Meaning for the LMV36
83	Bit 0 Valency 1	Lower control range limitation of control
	Bit 1 Valency 2...3	Upper control range limitation of control
	Bit 2 Valency 4...7	Interruption via disturbance pulses
	Bit 3 Valency ≥ 8	Curve too steep in terms of ramp speed
	Bit 4 Valency ≥ 16	Interruption of speed signal
	Bit 5 Valency ≥ 32	Quick shutdown due to excessive speed deviation
	Bit 6 Valency ≥ 64	Minimum speed fall below
	Bit 7 Valency ≥ 128	Maximum speed exceeded
	192	Incorrect setting: Minimum speed \geq maximum speed Incorrect setting: Neutral zone \geq close range
	255	Error forced travel PWM fan

13.10 Setting the parameters of the VSD

If a control signal of 95% (9.5 V) is not sufficient for the burner to deliver its rated capacity, you can proceed as follows:

- Set the maximum frequency to 105.3% of the motor's rated speed

In the case of a motor frequency of 50 Hz, this means:

Set the maximum frequency of the VSD to $50 \text{ Hz} \times 1.053 = 52.6 \text{ Hz}$ (on the VSD).

- Then, standardize the speed (refer to chapter *Standardization of speed*)

There is no risk of motor overload since only 95% of the maximum control signal is delivered during standardization and – later in operation – the effective speed is controlled and monitored.

Frequencies of between 50 Hz and 52.6 Hz are delivered only if these are needed for reaching the required speed due to increased output.

- Set the ramp times of the VSD according to chapter *Setting the ramp times*

13.11 Standardization of speed

Since the different types of fans operate at different speeds and signal handling should be as straightforward as possible, all speeds in the LMV36 are standardized between 0 and 100%. For this reason, the VSD module uses a parameter which contains the *Standard speed* (100% speed). All absolute speeds refer to this speed. If changes to the VSD or the fan are made, speed standardization should be repeated.



Caution!

- If automatic speed standardization is activated, or if the standardized speed is changed, the settings of air-fuel ratio control must be checked! Any change of the standardized speed alters the assignment between the percentage values parameterized on the curves and the speed
- When the parameter set (refer to ACS410 (J7352)) is restored, the standardized speed is restored also. If a data set is transferred to a new LMV36 via the restore process (e.g. during a device replacement), the standardization of the speed must be carried out again
- In pneumatic ratio control, at least one additional supervision threshold (parameter 667, 668 or 669) must be activated to carry out a speed standardization

No.	Parameter
667	Minimum prepurge speed
668	Maximum ignition speed
669	Minimum / maximum speed limitation in operation Index 0 = minimum speed Index 1 = maximum speed

Automatic speed standardization

To facilitate determination of the standardized speed, the LMV36 features automatic speed standardization. The speed must be standardized while in standby mode. Speed standardization is integrated in the setting process for electronic fuel-air ratio control, but can also be started later from the parameter setting level. When using a release contact for the VSD (external relay at fan output X3-05 pin 1), the fan output is controlled during speed standardization.

1. Start speed standardization

To start automatic speed standardization, set parameter 641 to 1.

No.	Parameter
641	Control of VSD's speed standardization Error diagnostics of negative values (refer to error 82) 0 = no speed standardization 1 = speed standardization active

2. Drive the air damper to the prepurge position

Speed standardization begins when the air damper travels to the prepurge position. When this position is reached, the damper should be fully open so that the fan operates at full capacity.

3. Control the VSD

The VSD is activated with 95% of the maximum voltage during active speed control. A margin of 5% allows the speed to be readjusted should environmental conditions change. This means that full speed (100%) is reached with 95% VSD control (refer to chapter *Setting the parameters of the VSD*). The specification for determining the standardized speed varies depending on the speed control setting and the selected operating mode. This means that a slightly reduced fan speed may be available.

Internal control parameter 661	Electronic ratio control (e.g. operating mode 1: <i>G mod</i>)	Pneumatic ratio control (e.g. operating mode 7: <i>G mod pneu</i>)
1	95% regulated operation	100% pneumatic
0	98% unregulated operation	98% pneumatic (deactivated control has higher priority than pneumatic ratio control)

No.	Parameter
661	LMV36 internal speed control 0 = deactivated (self-regulated PWM fan) 1 = activated (VSD)

4. Wait until the speed is higher and has stabilized

Before the 100% speed can be measured, the fan must have reached stationary conditions. This means that the fan must operate under stable conditions above 650 rpm. When this state is reached, a certain waiting time is observed, allowing the speed to eventually stabilize.

5. Measure the speed and store it

When the speed has stabilized, measure and store it as the *Standardized speed* (100% speed).

6. Close the standardization

When standardization is successfully completed, reset parameter 641 to 0. If standardization was not successful, parameter 641 assumes a negative value.

No.	Parameter
641	Control of VSD's speed standardization Error diagnostics of negative values (refer to error 82) 0 = no speed standardization 1 = speed standardization active

The value provides information on the cause of fault:

Value	Error	Remedy
-1	<i>Timeout of standardization (VSD ramp down time too long)</i>	Timeout at the end of standardization during ramp down of the VSD → Ramp time settings of the VSD are not shorter than those of the LMV36 (parameter: 523)
-2	<i>Storage of standardized speed not successful</i>	Error during storage of the standardized speed → lock the LMV36, then reset it and repeat the standardization
-3	<i>Line interruption speed sensor</i>	LMV36 receives no pulses from the speed sensor. 1. Motor does not run. 2. Speed sensor is not connected. 3. Speed sensor is not actuated by the sensor disk (check distance).

Value	Error	Remedy
-4	<i>Speed variation / VSD ramp up time too long / speed below minimum limit for standardization</i>	Motor has not reached a stable speed after ramp up. 1. Ramp time settings of the VSD are not shorter than those of the LMV36 (parameters 522, 523). 2. Characteristic of the VSD is not linear. Configuration of the voltage input at the VSD must accord with that of the LMV36 (parameter 645). 3. VSD does not follow quickly enough the changes of the LMV36. Check settings of the VSD (input filter, slippage compensation, hiding different speeds) 4. Speed of VSD lies below the minimum for standardization (650 rpm).
-5	<i>Wrong direction of rotation</i>	Motor's direction of rotation is wrong. 1. Motor turns indeed in the wrong direction → change parameterization of the direction of rotation or interchange 2 live conductors. 2. Sensor disk is fitted the wrong way → turn the sensor disk.
-6	<i>Unplausible sensor signals</i>	The required pulse pattern (60°, 120°, 180°) has not been correctly identified. 1. Speed sensor does not detect all tappets of the sensor disk → check distance 2. As the motor turns, other metal parts are detected also, in addition to the tappets → improve mounting. 3. Electromagnetic interference on the sensor lines → check cable routing, improve EMC
-7	<i>Invalid standardized speed</i>	The standardized speed measured does not lie in the permissible range. → Motor turns too slowly or too fast.
-15	<i>Speed deviation $\mu C1 + \mu C2$</i>	The speeds between $\mu C1$ and $\mu C2$ deviated too much. This can be caused by wrong standardized speeds (e.g. after restoring a data set to a new LMV36) → repeat standardization and check the fuel-air ratio
-20	<i>Wrong phase of phase manager</i>	Standardization was made in a wrong phase. Permitted are only phases ≤ 12 → load controller OFF, start standardization again
-21	<i>Safety loop / burner flange open</i>	Safety loop or burner flange is open → repeat standardization with safety loop closed
-22	<i>Air actuator not referenced</i>	Air actuator is not referenced or has lost its reference. 1. Check if the reference position can be approached. 2. Check if actuators have been mixed up. 3. If error only occurs after the start of standardization, the actuator might be overloaded and cannot reach its destination.
-23	<i>VSD deactivated</i>	Standardization was started with VSD deactivated → activate the VSD and repeat standardization
-24	<i>No valid operation mode</i>	Standardization was started without valid operation mode → activate valid operation mode and repeat standardization
-25	<i>Pneumatic air-fuel ratio control</i>	Standardization was started with pneumatic air-fuel ratio control → standardization with pneumatic air-fuel ratio control is not possible
-128	<i>Running command with no preceding standardization</i>	VSD is controlled but not standardized → make standardization

Value	Error	Remedy
-255	No standardized speed available	Motor turns but is not standardized → make standardization

The result of speed standardization (100% speed) can be read out via parameter. The speeds acquired by the 2 microcontrollers can differ by about 1.5%, the reason being slightly different resonator frequencies.

No.	Parameter
522	Ramp up
523	Ramp down
642.0	Standardized speed Index 0 = speed 1
642.1	Standardized speed Index 1= speed 2 (internal monitoring)
642.2	Fuel 1: Standardized speed Index 2 = speed 3
642.3	Fuel 1: Standardized speed Index 3 = speed 4 (internal monitoring)
645	Configuration of analog output 0 = DC 0...10 V 1 = DC 2...10 V 2 = DC 0/2...10 V



Note!

Different standardized speeds for fuel 0 and 1 in dual fuel operation are only necessary if the internal speed control of the LMV36 is active and the LMV36 is operated in mixed operation *electronic fuel / air ratio control / pneumatic fuel / air ratio control*.

13.12 Control of fan motor with pneumatic fuel-air ratio control

For the fan motor control for burners with pneumatic ratio control, only the control path is used with the factory setting

There is no need to connect a speed feedback signal and to have speed control (for operating modes, refer to chapter *Selection of operating mode*).

If speed monitoring is required in the pneumatic ratio control, additional supervision thresholds can be activated (see chapter *Acquisition of speed or Extended speed supervision*).

13.13 EMC of LMV36 and VSD

The function and EMC tests with the LMV36 have been successfully conducted in connection with the following makes and types of VSDs:

Siemens: SED2-0.37 / 22 X

Danfoss: VT2807

During operation, VSDs generate electromagnetic interference on the mains network. For this reason, the supplier's specifications must be strictly observed to ensure that makeup of the system is in compliance with EMC regulations:

Siemens: Operating Instructions → installation conforming to EMC

Danfoss: Technical Brochure → radio suppression filter

Data Sheet on Danfoss EMC filter for long motor cables



Caution!

When using other types of VSD, compliance with EMC regulations and trouble-free operation are not ensured!

13.14 Special conditions for PWM fan in electronic ratio control system

When using a PWM fan in the electronic ratio control system, different conditions must be observed or complied with.

This is connected, among other things, with the different properties of the PWM fan compared with VSDs.

- Fan characteristic
- Load dependency of the speed
- Reduced braking performance
- Acquisition of speed

13.14.1 Characteristics PWM fan

The LMV36 works with a standardized speed signal, with linear interpolation between standstill and the standardized speed (nominal speed). The requirement for this assumption is a linear fan characteristic, which is achieved solely by self-regulated PWM fans.

To prevent conflicts between self-regulated fans and the internal speed control of the LMV36, it must be deactivated (parameter 661; see chapter *Speed control*). The tolerance limits may also have to be adapted to the speed supervision (see chapter *Speed supervision*).

In contrast to a VSD, the fan speed of a PWM fan is heavily dependent on the load (air throughput) of the fan. This characteristic is partially balanced out by a self-regulated PWM fan, but still leads to a big time difference in the comparison between acceleration and deceleration. The extreme case here is a closed air damper, e.g. during the transition from postpurging to standby.

Another disadvantage of the current PWM fan is the partially significantly reduced braking performance (without the option of additional braking resistances, e.g. with a VSD). This means that the different ramp time values for run-up / run-down (parameter 522 / 523) have to be set. This behavior must also be taken into account with the modulating operating ramp (parameter 544).

The LMV36 also has the option of activating the actuators with a time delay (parameter 529). In this case, the braking performance is improved by carrying out the speed reduction with the air damper open. The air throughput increases the braking performance of the fan, which reduces the speed faster. This process can be set during the transition from prepurging to ignition (phase 35), when moving in postpurging (phase 71) and from postpurging to standby (phase 79). The air actuator is only moved to the relevant damper position once the ignition speed or standby speed is achieved.

If value 2 is set, an additional tolerance increase of 50% on the neutral zone (parameter 662) and the close range (parameter 663) of the speed supervision is possible outside of operation.

No.	Parameter
522	Ramp up
523	Ramp down
529	Separate movement of the fan (ignition speed / postpurge speed) 0 = deactivated 1 = activated 2 = activated (50% tolerance increase outside operation)
544	Ramp modulating
661	LMV36 internal speed control 0 = deactivated (self-regulated PWM fan) 1 = activated (VSD)
662	Neutral zone of the speed supervision
663	Close range of the speed supervision

13.14.2 Acquisition of speed PWM fan

Due to design-related restrictions, it is usually not possible to mount a sensor disk for generating an independent, asymmetrical (direction of rotation sensitive) speed signal on a PWM fan. Instead, the symmetrical speed signal of the PWM fan based on the Hall effect is used. No direction of rotation recording is possible due to the symmetrical structure.

The PWM function in the electronic ratio control system is only permitted in conjunction with a fail-safe feedback signal of the fan with error analysis (in accordance with DIN EN 60730-1 class C).

For a plausibility check with regard to a fault-free Hall feedback, an additional speed-dependent air pressure switch can therefore be used for a comparison between the speed signal and the resulting air pressure (see chapter *Additional speed-dependent air pressure switch*).

With a correspondingly high ON threshold of the air pressure switch, this also includes verification of the correct direction of rotation and the required air quantity for prepurging and high-fire.

The system manufacturer / system operator must determine and guarantee that adequate fail-safe properties are achieved in accordance with standards.

The LMV36 fulfill the requirement of the UL standard, EN 12067-2 and ISO 23552-1 (gas/air ratio control) if the following basic principles are met:

- Directly connected PWM fan
- Directly fail-safe feedback signal of the fan according to EN 60730-1 class C

If the basic principles outlined above are not met, the local safety regulations for the application must be checked by the system manufacturer / system operator.

The safety of the entire LMV36 must be guaranteed by the system manufacturer / system operator.



Attention!

To avoid personal injury or damage to property, the following note must be observed.

If the feedback signal of the fan does not correspond to EN 60730 - 1 class C, there is a risk of unclean combustion, which can lead to the following:

- CO emissions and poisoning
- Explosion
- Damage to property

13.15 Trim function

The trim function enables the specified speed of the ratio control curve to be changed in adjustable limits via 4...20 mA input. The residual oxygen content of the flue gas or the supply air temperature can be used for determining the current setting. Depending on the setting, the trimming can be activated from ignition or only in operation, between low-fire and high-fire, after an adjustable wait time has elapsed. No trimming of the fan speed takes place during the curve setting. The restriction of the trimming range must be selected so that no unsafe state can occur in the application under any environmental conditions. The LMV36 also has various options for ensuring that the trim function or the components involved in the trim function run correctly (see chapter *Optional internal checks* / chapter *Optional external checks*).



Invalid output specification during trim function with LMV36.520A1

Note!

Version LMV36.520A1 has no load controller inputs OPEN / CLOSED. When the trim function is activated, the output specification via the analog input also no longer applies, which, in this case, only leaves the specification from the building automation via Modbus as the lowest priority load controller source. To protect the LMV36 from an invalid output specification (error code C: 60) in this constellation after switching on or after a fuel change, a valid Modbus standard output must be defined if the building automation is interrupted (Modbus parameter 148/149; presetting is invalid).

No.	Parameter
148	<p>Predefined output in the event of communication breakdown with building automation</p> <p>Setting values: For modulating operation, the setting range is as follows: 0...19.9 = burner off 20...100 = 20...100% burner output (20 = low-fire position)</p> <p>For multistage operation, use the following settings: 0 = burner OFF P1...P3 = stage 1...stage 3</p> <p>Invalid = no output predefined by the building automation system in the event of communication breakdown</p> <p>Default setting: <i>Invalid</i></p>
149	<p>Fuel 1: Predefined output in the event of communication breakdown with building automation</p> <p>Setting values: For modulating operation, the setting range is as follows: 0...19.9 = burner off 20...100 = 20...100% burner output (20 = low-fire position)</p> <p>For multistage operation, use the following settings: 0 = burner OFF P1...P3 = stage 1...stage 3</p> <p>Invalid = no output predefined by the building automation system in the event of communication breakdown</p> <p>Default setting: <i>Invalid</i></p>



Note!

A detailed description of parameters 148 and 149 can be found in the chapter *Output specification via building automation*.

13.15.1 Settings and mode of operation

The maximum trimming range of -15...+25% cannot be changed and is intrinsically linked to the 4...20 mA specification of the analogue input (40% trimming range based on 16 mA → 1% trim per 0.4 mA).

- 20 mA = +25% speed correction
- 10 mA = 0% or no speed correction
- 4 mA = -15% speed correction

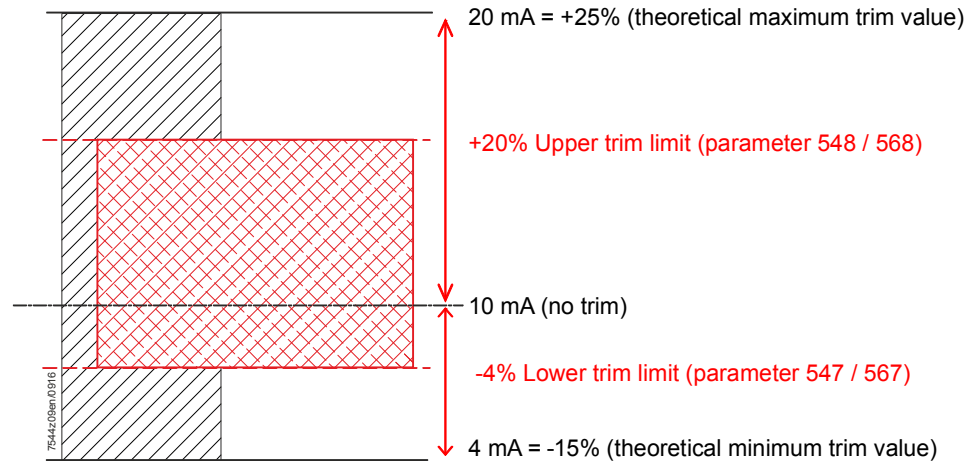

Figure 96: Setting range trim limits

In order to adapt to the application and the environmental conditions present at the time the settings are made, the trim range can be restricted independently for each fuel (the setting 0% deactivates the relevant direction of influence). It is also possible to set a wait time for trim function activation, e.g. to obtain more reliable residual oxygen content values for O₂ trimming. The wait time during operation can be practically deactivated by selecting an extremely low value if the trim function is used as temperature compensation.

To influence altered environmental conditions in the ignition and to improve the ignition behavior, the ignition speed can also be adapted depending on the ambient temperature where necessary. The temperature-dependent offset on the ignition speed specified in the prepurging is retained until the delay time has elapsed in operation.

Impact of the trimming with different outputs

It is unlikely that an identical trim correction (e.g. +10% speed) will have the same impacts for low-fire and high-fire. This is why load-dependent trim damping is used. The damping factor is based on low-fire and can be set in the value range 0% (no damping) to 100% (no trimming with low-fire). The damping is interpolated linearly to the low-fire based on the current (limited) trim correction value. The output-dependent impact of the trim correction can already be taken into account by the external control in the current setting.



Note!

The impact of the trimming is changed very slowly with 0.1% per 0.2 seconds. This means that it takes 50 seconds to deactivate the trim function starting from +25%.

No.	Parameter
204	Behavior if analog input is invalid (4...20 mA) 0 = deactivate default output low-fire / trim function (with warning message) 1 = safety shutdown + startup prevention 2 = deactivate default output low-fire / trim function (without warning message)
530	Activation trim function 0 = inactive 1 = active 2 = active (including test function for analog input) 3 = active (including ignition speed) 4 = active (including ignition speed and analog input test)
547	Lower range limit trim function
548	Upper range limit trim function
549	Damping factor for trim function (based on low-fire)
550	Delay time / wait time for trim function after entering phase 60
551	Wait time until response with active trim limitation
552	Behavior if maximum trim limitation time is exceeded 0 = warning message only (trim impact remains active) 1 = warning and deactivation of the trim function 2 = shutdown
567	Lower range limit trim function
568	Upper range limit trim function
569	Damping factor for trim function (based on low-fire)
570	Delay time / wait time for trim function after entering phase 60
571	Wait time until response with active trim limitation
572	Behavior if maximum trim limitation time is exceeded 0 = warning message only (trim impact remains active) 1 = warning and deactivation of the trim function 2 = shutdown

13.15.2 Optional internal checks

The LMV36 has various settings and monitoring options to ensure that the trim function runs correctly and error-free. The external control unit and control section are used here in places. The OEM is responsible for implementing the necessary measures for fulfilling the local requirements.

Plausibility check for the curve setting

When the trim function is activated, the LMV36 carries out permanent supervision of the speed curve. In order to cover the desired range with the trim function, a sufficient reserve must be available in the curve setting (e.g. upper trim limit 10% → 90% maximum curve setting). Otherwise, it wouldn't be possible to carry out the desired trim correction, as the speed would be limited by the minimum or maximum limitation.

Error-code	Diagnostic code	Meaning for the LMV36
155	#	Trim function: Invalid curve setting VSD / PWM fan
	0..9	Minimum value VSD curve fall below
	20..29	Maximum value VSD curve exceeded
	40..49	Fuel 1: Minimum value VSD curve fall below
	60..69	Fuel 1: Maximum value VSD curve exceeded

Plausibility check for range limitation

A plausibility check can be activated to show if the LMV36 remains on a range limit of the trim function for a defined time (time setting = 0 deactivates the check / warning / shutdown).

This can be used to identify an incorrect setting in the trim function.

In the default setting, no shutdown takes place and only a warning is generated.

This means that the LMV36 remains in operation.

Deactivation of the trim function and a shutdown can also be triggered in response to the system remaining on a range limit for too long.

If error code C:156 is only output as a warning message, it can only be seen for the period the error is active, as warning messages are not saved permanently in the error history.

The PLC must therefore read out the current error memory of the LMV36 cyclically via Modbus (e.g. every 2...30 s) and save a corresponding warning message permanently.

Error-code	Diagnostic code	Meaning for the LMV36
156	#	Trim function: Maximum time for range limit exceeded
	0	Trim function at lower limit
	1	Trim function at upper limit
	10	Fuel 1: Trim function at lower limit
	11	Fuel 1: Trim function at upper limit

Analogue input test during burner startup

A test sequence with 2 current thresholds can be used to identify errors in the analog input during burner startup.

To this end, the PLC must deliver a current of 10 mA (0%) during standby and a current of 4 mA (-15%) during *traveling to prepurging* or the first 2 seconds in *prepurging*.

The LMV36 uses these test values to check for fault-free function of the analog value recording and can therefore detect component faults and drift.

The expected values are also used for indirect supervision of the Modbus communication and the external control (PLC).

In the event of an error, the burner startup is prevented (test in standby) or canceled (test in prepurging).

The test can only be carried out during burner startup, a cyclical test during operation is not possible.

For this reason, the forced intermittent operation may not be switched off when the analog input test is activated.

This ensures that the analog input test is carried out at least once every 24 hours.

The supervision is carried out by LMV36.

The PLC or the external control can read out the LMV36 phase information required for the test via Modbus.

Error-code	Diagnostic code	Meaning for the LMV36
157	#	Trim function: Analog input test
	0	Analog value standby
	1	Analog value prepurging

13.15.3 External tests (optional)

In addition to the LMV36 internal tests, various states may also be monitored by an external PLC or control. Selected process parameters, e.g. the current phase, can be read out via Modbus for this purpose. In this case, the LMV36 is shut down via a self-locking NC contact of the PLC in the safety loop (X3-04 pin 1 and pin 2) or in series with the load controller ON signal (X5-03 pin 1 and pin 4).

Impact of the trimming range restriction with PLC

The defined assignment between the current setting and trim impact (4...20 mA is shown as -15...+25 %) must also be taken into account by the PLC. Particularly when reducing the possible trim range (parameter 547 / 548 or 567 / 568), the PLC must also take the reduced limit values into account. The relevant parameters can be read out via Modbus for this purpose.

To guarantee that, despite tolerances between the PLC analog output and LMV36 analog input, the maximum limits for the trimming can be achieved, the PLC must deliver a current value that is approx. 0.5% (i.e. approx. 0.2 mA) off the set limit values (over for the upper limit, under for the lower limit).

No.	Parameter
547	Lower range limit trim function
548	Upper range limit trim function
567	Lower range limit trim function
568	Upper range limit trim function

External supervision: Target/actual comparison of the trim specification

The single-channel version of the LMV36 analog value recording is not fail-safe. The control unit responsible for the specification of the 4...20 mA signal for O₂ trimming can either trigger a safety shutdown or shutdown via an NC contact if an excessively large deviation is detected between the trim setpoint and the determined trim specification of the LMV36. To this end, the trim specification of the LMV36 can be read out via Modbus (raw value, target value with limitation and damping, as well as the current active trim influence).

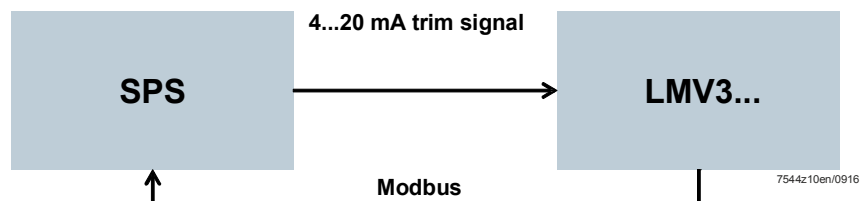

Figure 97: Trim supervision with PLC

With this supervision, the PLC can create a closed loop over the analog input of the LMV36 and the trim specification, including the analog output of the PLC, via Modbus.

External supervision of the residual oxygen content in the flue gas

Particularly for a trim specification based on an O₂-measurement, there is the option of additional supervision of the flue gas values with regard to the minimum / maximum O₂ value. For this, the PLC can read out the LMV36 phase and LMV36 output via Modbus and supervise output-dependent minimum / maximum O₂ values. This ensures that the application is always operated in the correct working range.

In the event of an error, a safety shutdown via the safety loop or a shutdown via the load controller ON signal can be triggered as a response as required. Another option in the event of an error is to deactivate the trim function via a 10 mA current setting in the PLC.

Trim range test via PLC

Once the curve setting or commissioning is complete, a trim range test must be carried out to check the influence on the application.

The test is initiated by the PLC, which provides both the output specification (via Modbus) and the trim specification (via 4...20 mA).

Test sequence:

1. Starting point:
The PLC delivers a stationary output specification
(→ no modulation during the test sequence)
2. Lower trim limit test:
The PLC delivers the minimum current setting (4 mA)
Verification of the flue gas values if minimum trim influence is active
3. Upper trim limit test:
The PLC delivers the maximum current setting (20 mA)
Verification of the flue gas values if maximum trim influence is active

Steps 1...3 must be carried out at least for low-fire and high-fire to guarantee a correct trim setting.

13.16 Description of connection terminals

13.16.1 VSD

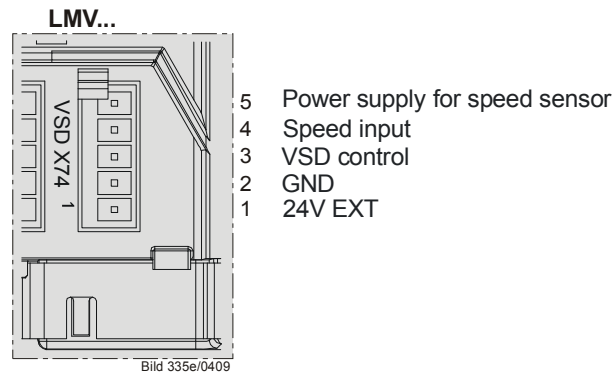

Figure 98: VSD connection X74

13.16.2 PWM fan

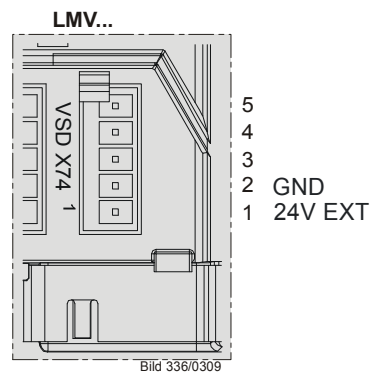

Figure 99: PWM fan X74

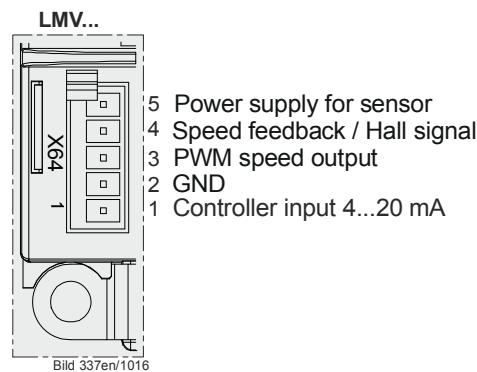

Figure 100: PWM fan X64

14 Load output X74 pin 3

The load output is only available as an alternative to VSD control. If the VSD is deactivated, the output for the VSD delivers the current burner output. The analog output is a voltage output and – using parameter 645 – can be switched between DC 0...10 V, DC 2...10 V and DC 0/2...10 V.

Parameter 645	Voltage range	Remarks
0	DC 0...10 V	No detection of line interruption
1	DC 2...10 V	Detection of line interruption possible
2	DC 0/2...10 V	No detection of line interruption. Recommended setting in connection with Micromaster VSD



Note

When changing the analog output configuration from DC 0...10 V to DC 2...10 V or DC 0/2...10 V, the voltage values with modulating, 2-stage and 3-stage operation change (refer to chapter *Modulating operation*, chapter *2-stage operation* and chapter *3-stage operation*).

Conversion: $\text{New value} = (\text{initial value} * 0.8) + 2$

Example: Initially 2 V $\rightarrow (2 * 0.8) + 2 = 3.6$ V

Initially 5 V $\rightarrow (5 * 0.8) + 2 = 6$ V

No.	Parameter
645	Configuration of analog output 0 = DC 0...10 V 1 = DC 2...10 V 2 = DC 0/2...10 V

14.1 Safe separation of mains voltage and extra low-voltage



Caution!

The load output is designed for SELV or PELV (refer to chapter *Electrical connection of the LMV36 and AGM60*).

For this reason, strict separation from the mains voltage side must be ensured!

This necessitates power supply by an external power pack (X74 pin 1, X74 pin 2).

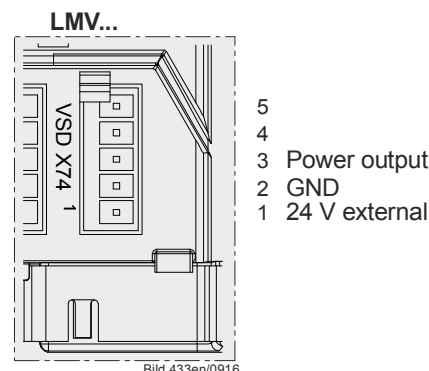

Figure 101: Power output

14.2 Modulating operation

Actual value	Voltage	Curvepoint	Display / output value
Off	DC 0 V	---	Off
Ignition load	DC 1 V	P0	10%
Low-fire	DC 2 V	P1	20%
High-fire	DC 10 V	P9	100%

The values between low-fire and high-fire are interpolated in a linear manner.

14.3 2-stage operation

Actual value	Voltage	Curvepoint	Display / output value
Off	DC 0 V	---	Off
Stage 1	DC 5 V	P1	P1
Stage 2	DC 10 V	P2	P2

14.4 3-stage operation

Actual value	Voltage	Curvepoint	Display / output value
Off	DC 0 V	---	Off
Stage 1	DC 3 V	P1	P1
Stage 2	DC 5 V	P2	P2
Stage 3	DC 10 V	P3	P3

15 Fuel meter input X75 pin 1 / X75 pin 2

A fuel meter can be connected to acquire the amount of fuel burnt.

The fuel meter function is only available as an alternative to VSD control. If the VSD is deactivated, a fuel meter can be connected to terminals X75 pin 1 and X75 pin 2.

The pulses per volume unit can be set separately for Fuel 0 and Fuel 1. In terms of hardware, the fuel meter input exists only once however, that is, the change between 2 pulse counters must be made externally. Changeover can be accomplished either via the fuel selector or an additional contactor at the safety valve output of the AGM60.

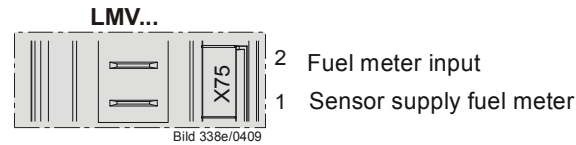

Figure 102: Fuel meter input X75

15.1 Configuration of fuel meter

15.1.1 Types of fuel meters

The LMV36 is designed for use with fuel meters equipped with a Reed contact. Pulse frequency at maximum fuel throughput must be below 300 Hz.

15.1.2 Configuration of pulses per volume unit

Depending on the type of fuel meter used, the number of pulses supplied per m^3 or l fuel must be parameterized. A maximum of 400 pulses per volume unit can be preset. The correct amount of fuel is acquired only when this parameter is set.

When the parameter is 0, the fuel meter stops.

No.	Parameter
128	Fuel meter: Pulse valency (pulses/volume unit)
129	Fuel meter 1: Pulse valency (pulses/volume unit)

15.1.3 Reading and resetting the meter readings

No.	Parameter
167	Fuel volume resettable [m^3 , l, ft^3 , gal]
177	Fuel 1: Fuel volume resettable (m^3 , l, ft^3 , gal)

The cumulated fuel volume can be read out per parameter. The meter reading can also be reset on the parameter level.

15.2 Fuel throughput

With the fuel meter connected, the LMV36 calculates continuously the current fuel throughput. The time required for calculating the fuel throughput varies and lies between 1 and 10 seconds. If the meter delivers no pulses for more than 10 seconds, the display shows **0** fuel throughput. This means that when fuel throughput is at its minimum, the sensor should have a pulse frequency of at least 0.1 Hz. The display is smoothed to improve the settling process. With fuel throughput at its maximum, the maximum frequency is 300 Hz.

15.2.1 Configuration

Calculation of fuel throughput is configured based on the pulse valency of the connected fuel meter.

No.	Parameter
128	Fuel meter: Pulse valency (pulses/volume unit)
129	Fuel meter 1: Pulse valency (pulses/volume unit)

When the pulse valency is set to **0.00**, the display shows **0** throughput.

15.2.2 Reading out the fuel throughput

The current fuel throughput can be read out via the following parameter on the service menu:

No.	Parameter
960	Fuel throughput in volume unit /h (m ³ /h, l/h, ft ³ /h, gal/h)

Display of fuel throughput is possible up to 6553 volume units/h.



Note

Display of fuel throughput up to a value of **99.9** on the service menu is made with one decimal place, from **100** with no decimal place.

Shielding:

For shielding the cables on the VSD, refer to:

- Siemens *SED2* VSD Commissioning Manual (G5192), chapters 4 and 7, or
- Danfoss Operation Manual *VLT 6000* (MG60A703), chapter *Installation*

Switching between 2 ratio control curves

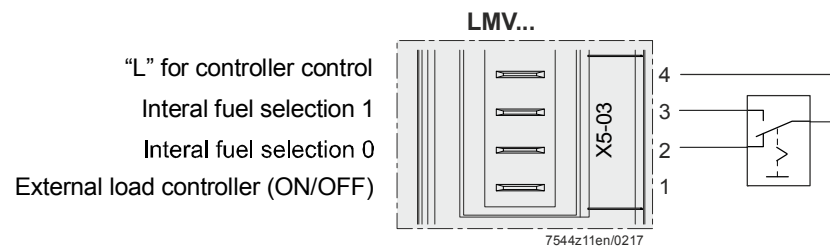

Figure 104: Switching between 2 ration control curves

17 Special feature: Burner identification

The OEM must assign an individual burner identification to every burner. This ensures that, during backup / restore, incompatible parameter sets cannot be copied between different burners (also refer to documentation on ACS410 PC software chapter *Backup / Restore* and in this document chapter *Backup / Restore*).

No.	Parameter
113	Burner identification

18 Connection to superposed systems

18.1 General information and building automation functions

Communication with a building automation system is made possible via a data link using the COM X92 port and a special interface with galvanic separation and physical bus level adaptation. This port can be used for connection of a LMV36 with Modbus, depending on the configuration made.

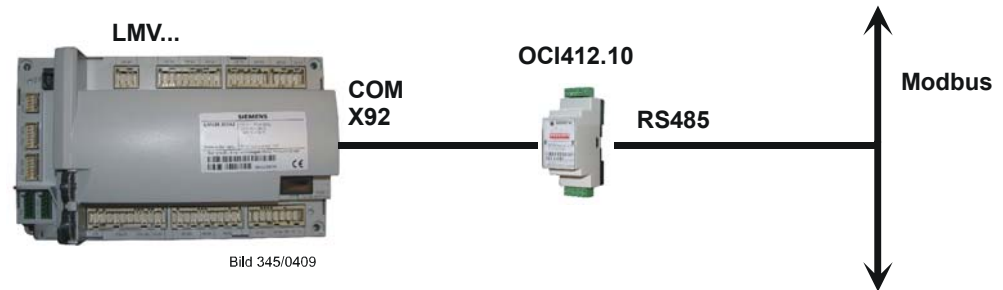

Figure 105: Connection via COM X92 to superposed systems



Note
Breakdown of bus communication

If the LMV36 detects a breakdown of bus communication, the building automation system must rewrite the value upon restoration of communication for the Modbus operating mode and predefined target output



Note
Fuel changeover on the LMV36.

After a change of fuel, the building automation system must rewrite the predefined target output. A change of fuel can be detected by cyclic sampling of the type of fuel currently burnt.

General setting values for connection of the LMV36 to building automation (for factory settings, refer to the *Parameter list*):

Bus communication may only be interrupted for the time set.

If communication is disturbed for a longer period of time, the LMV36 delivers a fault status message and the values set in the LMV36 by building automation are reset.

No.	Parameter
141	Operating mode building automation 0 = off 1 = Modbus 2 = reserved
142	Setback time in the event of communication breakdown Setting value: 0 = deactivated 1...7200 s
148	Predefined output in the event of communication breakdown with building automation Setting values: For modulating operation , the setting range is as follows: 0...19.9 = burner off 20...100 = 20...100% burner output (20 = low-fire position) For multistage operation , use the following settings: 0 = burner OFF P1...P3 = stage 1...stage 3 Invalid = no output predefined by the building automation in the event of communication breakdown Default setting: <i>Invalid</i>
149	Fuel 1: Predefined output in the event of communication breakdown with building automation Setting values: For modulating operation , the setting range is as follows: 0...19.9 = burner off 20...100 = 20...100% burner output (20 = low-fire position) For multistage operation , use the following settings: 0 = burner OFF P1...P3 = stage 1...stage 3 Invalid = no output predefined by the building automation in the event of communication breakdown Default setting: <i>Invalid</i>

The factory settings of the parameters are shown on the *Parameter list*.



Note

For a detailed description of parameters 148 and 149, refer to chapter *Default output via building automation*.

18.2 Modbus

With this type of bus protocol, the LMV36 operates as a slave on the Modbus and the transmission mode used is RTU (Remote Terminal Unit).

For more detailed information, refer to the Modbus User Documentation (A7541).

No.	Parameter
145	Device address for Modbus of LMV36 Setting value: 1...247
146	Baud rate for Modbus 0 = 9600 1 = 19200
147	Setting of parity for Modbus communication 0 = none 1 = odd 2 = even

The factory settings of the parameters are shown on the parameter list.



Note

If bus communication breaks down, the mode, Modbus operating mode and predefined target output must be rewritten.

19 PC software ACS410

The ACS410 PC software serves primarily as an operating module for the LMV36, providing the following basic functions:

- Visualization of system state via the following data:
 - Parameters
 - Process data
- Configuration and parameterization of the LMV36 (individual parameters)
- Backup and recovery of parameter sets



Note
For notes on operation and commissioning, refer to chapter *Operation*.

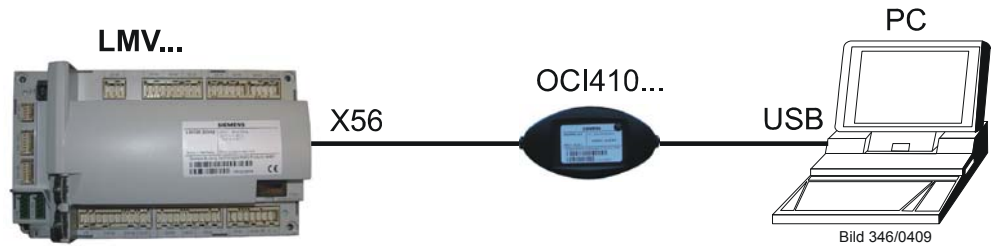

Figure 106: Communication with display / BC interface (RJ11 jack) (X56)

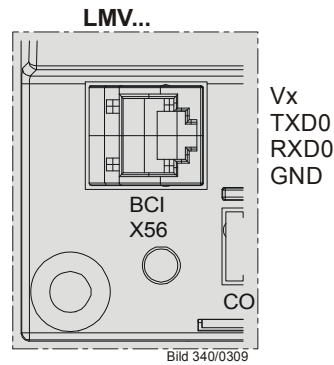

Figure 107: Display input / BC interface (RJ11 jack) X56

If communication between the LMV36 and the ACS410 (70 seconds) has broken down, the password level is reset to *Info / Service*.



Caution!
Interruption of communication between the LMV36 and the ACS410 (30 seconds) during the time the curves are set leads to lockout!

Error-code	Diagnostic code	Meaning for the LMV36
167	9	Manual locking by the PC software ACS410 Communication breakdown

20 Error history

The LMV36 provides an error history in which the last 25 errors are stored. The first entry represents the current error state and can also be *error-free*, refer to *Error code list*.

Error code	Diagnostic code	Meaning for the LMV36
200 OFF	#	LMV36 error-free

20.1 Error classes

The errors are subdivided into error classes, depending on the severity of the switch-off response. The current error shows all classes. Only the errors of the most important classes are included in the history.

Error class	Priority	Meaning	History
0	Highest	Lockout	●
1		Safety shutdown with software reset	●
2		Undervoltage	
3		Safety shutdown: Safety phase	●
4		Safety shutdown: Start prevention	
5		Safety shutdown: Shutdown	●
6	Lowest	Message without shutdown response	

20.2 Makeup of error history

Parameter	Index	Description
701		Current error state, can also be error-free
	.01	Error code (200 = error-free) → refer to <i>Error code list</i>
	.02	Diagnostic code → refer to <i>Error code list</i>
	.03	Error class → error classes
	.04	Phase: Phase in which error occurred → sequence diagrams
	.05	Startup counter: (parameter 166) at which the error occurred
	.06	Output: Burner output at which the error occurred
	.07	Fuel in which error occurred
702	.01..07	Latest error in the history
•		
•		
•		
725	.01..07	Oldest error in the history

No.	Parameter
166	Total number of startups

Deleting the error history

Both the service menu and the parameter setting menu show the error history. The display on the service menu can be deleted in a way that the only errors shown are those that occurred after the deletion. The error history on the parameter setting menu cannot be deleted.

For the deletion, parameter 130 must be set to **1** and then to **2** within 6 seconds. When the parameter returns to **0**, the deletion process is completed.

No.	Parameter
130	Delete display of error history To delete the display: Set parameter to 1 , then to 2 Return value 0: Job successfully completed Return value -1: Timeout of 1_2 sequence

21 Lifecycle function

If the startup counter exceeds a defined threshold, a display error code is set and displayed. The error can be acknowledged.

The display code is always set in standby (when there is no heat request).

Hence, the moment the threshold is exceeded, the user is notified that the end of the lifecycle of the LMV36 will soon be reached.

Error code	Diagnostic code	Meaning for the LMV36
116	0	Designed life time exceeded (250'000 startups)



Note

The LMV36 should be replaced when this message appears.

22 Safety notes on use of the AZL2

Caution!

To prevent the risk of fire and explosions, damage to heating plant or damage resulting from improper use of the products, ensure that the following safety notes are observed:

The burner management system covered by the present Basic Documentation may only be used as specified and only in connection with the appropriate burner and heating plant.

The burner management system with its AZL2 and the associated heating control system may only be installed and commissioned by authorized technical personnel.



The AZL2 may only be used in dry spaces. Do not use AZL2 outdoors and protect it against excessive temperatures and frost, and liquids, such as water, oil, fuel oil, etc.

Follow exactly the procedures and setting notes given in this Basic Documentation. Appropriately identified settings must only be made by authorized technical personnel.

If the AZL2 is dusty or dirty, clean it with a dry cloth.

Do not carry out any maintenance or repair work on the AZL2. Such work may only be performed by authorized technical personnel.

If you have any questions in connection with the AZL2, please contact your heating engineer or refer to one of the addresses given in this Basic Documentation.

23 Operating via AZL2

23.1 Description of unit/display and buttons

Function and operation of unit versions AZL21 and AZL23 are identical.

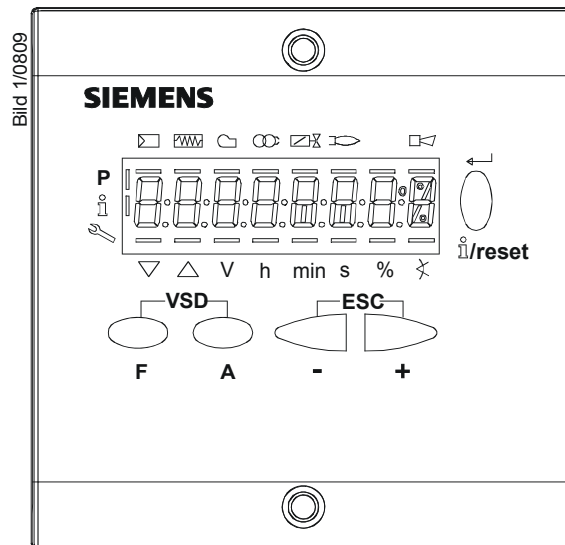















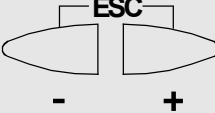

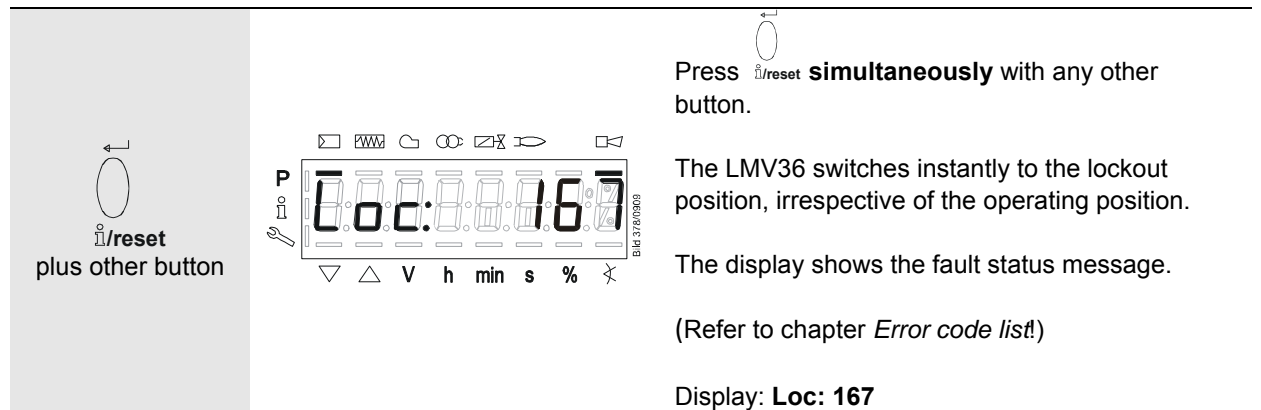



Figure 108: Description of unit/display and buttons

Button	Function
 F	Button F - For adjusting the fuel actuator (keep  depressed and adjust the value by pressing  or )
 A	Button A - For adjusting the air actuator (keep  depressed and adjust the value by pressing  or )
 F A	Buttons A and F: Parameter function - For changing to parameter setting mode P (press simultaneously  and  plus  or )
 i/reset	Info and Enter button - For navigating in info or service mode * Selection (symbol flashing) (press button for <1 s) * For changing to a lower menu level (press button for 1...3 s) * For changing to a higher menu level (press button for 3...8 s) * For changing the operating mode (press button for >8 s) - Enter in parameter setting mode - Reset in the event of fault - One menu level down
 -	- button - For decreasing the value - For navigating during curve adjustments in info or service mode
 +	+ button - For increasing the value - For navigating during curve adjustments in info or service mode
 - +	+ and - button: Escape function (press  and  simultaneously) - No adoption of value - One menu level up

23.4 Special functions

23.4.1 Manual lockout



Press  **simultaneously** with any other button.

The LMV36 switches instantly to the lockout position, irrespective of the operating position.

The display shows the fault status message.

(Refer to chapter *Error code list!*)

Display: **Loc: 167**

The reset must be carried out as follows:

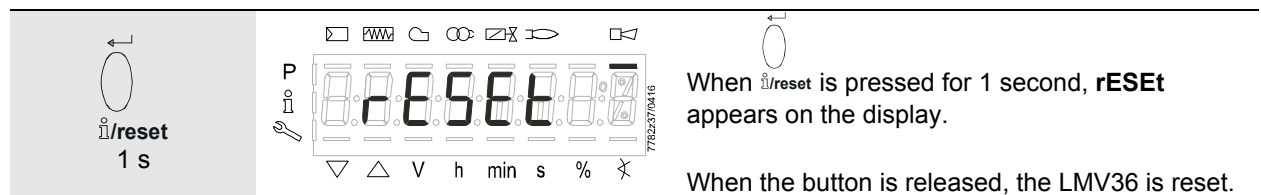

When  is pressed for 1 second, **rESEt** appears on the display.

When the button is released, the LMV36 is reset.

23.4.2 Manual control (manual request for output)

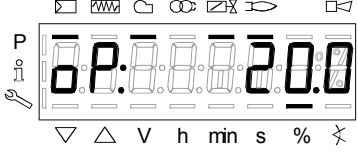
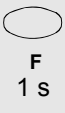
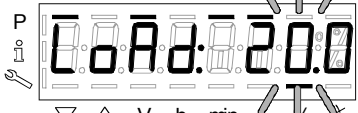
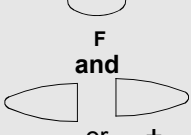
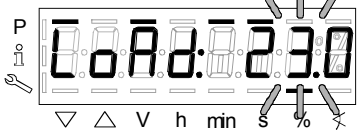
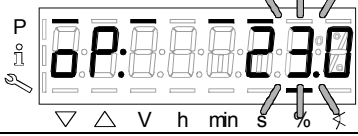
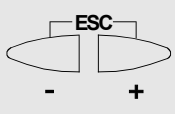
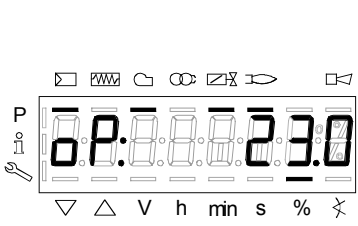
		<p>Burner is in operation.</p> <p>The display shows oP: on the left, the percentage of the current output on the right.</p> <p>Example: oP: 20.0</p>
 <p>F 1 s</p>		<p>Press F for 1 s.</p> <p>The display shows LoAd: the current output flashes.</p>
 <p>F and - or +</p>		<p>Press - or + to adjust the required manual output.</p> <p>Example: oP: 23.0</p>
		<p>Release F.</p> <p>The current manual output flashes, indicating that manual control is activated.</p>
 <p>ESC - +</p>		<p>Press - + for 3 seconds to return to automatic mode.</p> <p>The output no longer flashes.</p> <p>The display shows oP: on the left, the percentage value on the right.</p> <p>Example: oP: 23.0</p>

23.5 Timeout for menu operation

The time for automatically leaving the parameter setting level can be adjusted between 10 and 120 minutes, using the following parameter:

No.	Parameter
127	Timeout for menu operation

If, during that period of time, there is no operation via the AZL2, the parameter setting level is quit and the password level reset to *Info / Service*.



Caution!

In addition, this timeout or interruption of communication between LMV36 and the AZL2 during the time the curves are set, leads to lockout!

Error-code	Diagnostic code	Meaning for the LMV36
167	8	Manual locking by the AZL2 Timeout / communication breakdown

23.6 Backup / restore

Using the AZL2, the settings made on the LMV36 can be stored (backup) and then transferred back to the LMV36 at a later point in time.

Creating a backup data set

No.	Parameter
050.0	Index 0: Creation of backup

The following parameters can be used to read information about the backup data set:

No.	Parameter
055	Burner identification of the AZL2 backup data set
056	ASN extraction of the AZL2 backup data set
057	Software version used when creating the AZL2 backup data set

Restoring a backup data set

To transfer a backup data set back to the LMV36, the parameter must be set to **1**.

No.	Parameter
050.1	Index 1: Execute restore

23.6.1 Backup

		<p>Parameter 000: flashes.</p> <p>Display: Parameter 000: flashes, Int does not.</p>
		<p>/reset</p>
		<p>Press + to select parameter 050</p> <p>Display: Parameter 050. flashes, index 00: and value 0 do not.</p>
		<p>/reset</p>
		<p>Press to select parameter bAC_UP</p> <p>Display: Parameter bAC_UP</p>
		<p>/reset</p>
		<p>Press to select the backup process.</p> <p>Display: Value 0</p>
		<p>Press + to shift the value in change mode 1 position to the left.</p> <p>Display: Value 1 flashes</p> <p>Note To detect potential display errors, the value is displayed 1 place shifted to the left.</p>
		<p>Press to activate the backup process.</p> <p>Display: 1 appears</p>

Approx. 5 s

After about 5 seconds (depending on the duration of the program), **0** appears on the display, indicating the end of the backup process.

Display: **0**



Note

If an error occurs during the backup process, a negative value is displayed. For error diagnostics, the cause of the error can be determined from the diagnostic code of error message 137 (see *Error code list*).





Caution!

We recommend to make a backup whenever a parameter is changed!

23.6.2 Restore

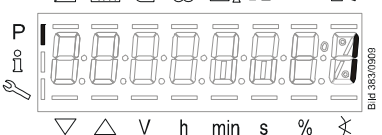
	<p>Parameter 000: flashes.</p> <p>Display: Parameter 000: flashes, Int does not.</p>
	<p>Press + to select parameter 050</p> <p>Display: Parameter 050. flashes, index 00: and value 0 do not.</p>
	<p>Press i/reset to go to parameter bAC_UP.</p> <p>Display: Parameter bAC_UP</p>
	<p>Press + to go to the rEStorE function.</p> <p>Display: Parameter rEStorE</p>
	<p>Press i/reset to select the restore process.</p> <p>Display: Value 0</p>
	<p>Press + to shift the value in change mode 1 position to the left.</p> <p>Display: Value 1 flashes.</p>
	<p>Note To detect potential display errors, the value is displayed 1 place shifted to the left.</p>

		<p>Press  to activate the restore process.</p> <p>Display: 1 appears</p>
---	---	--

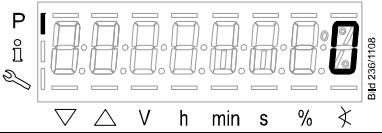
<p>Ca. 8 s</p>		<p>After about 8 seconds (depending on the duration of the program), 0 appears on the display, indicating the end of the backup process.</p> <p>Display: 0</p>
--------------------	---	--



Note

- Before restoring the backup data on the LMV36, the latter compares the burner identification and product no. (ASN) with the burner identification and product no. (ASN) of the backup data set. If the data accord, they are restored. If not, the restore process is aborted. In case of abortion, or if an error occurs during the restore process, the display shows a negative value. For error diagnostics, the cause of the error can be determined from the diagnostic code of error message 137 (see *Error code list*). When the restore process is successfully completed, value **0** appears on the display. The LMV36 is supplied with undefined burner identification. In that case, the restore process from the AZL2 is possible without having to enter the burner identification in the LMV36
- Information **Err C: 136 D: 1** (restore started) is displayed for a short moment



Caution!

- **On completion of the restore process, the sequence of functions and the parameter settings must be checked**
- **When using a VSD, it might be necessary to repeat standardization**

24 Operation of LMV36 via the AZL2

24.1 Normal display

Normal display is the standard display in normal operation, representing the highest menu level. From the normal display, you can change to the info, service or parameter level.

24.1.1 Display in standby mode

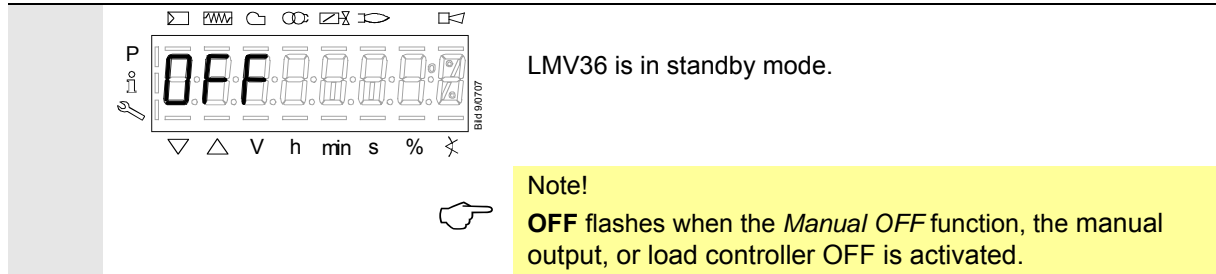

LMV36 is in standby mode.

Note!
OFF flashes when the *Manual OFF* function, the manual output, or load controller OFF is activated.

24.1.2 Display during startup / shutdown

24.1.2.1. Display of program phases

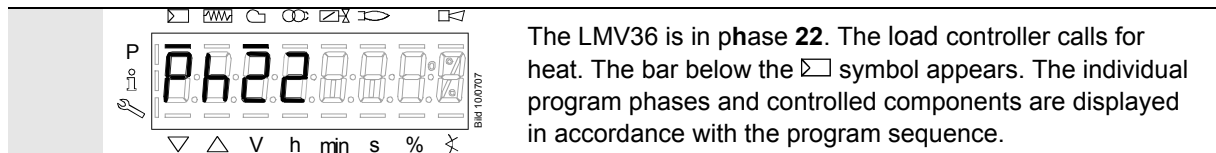

The LMV36 is in phase **22**. The load controller calls for heat. The bar below the □ symbol appears. The individual program phases and controlled components are displayed in accordance with the program sequence.

24.1.2.2. Display of program phase with remaining running time until end of the phase is reached

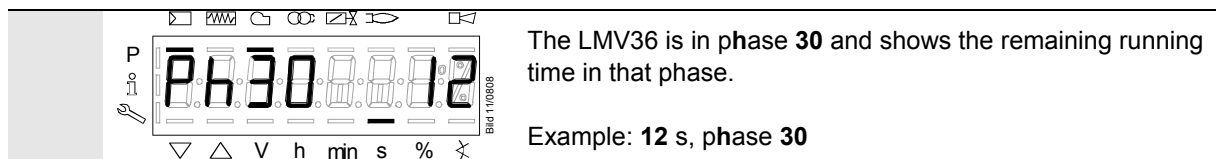

The LMV36 is in phase **30** and shows the remaining running time in that phase.
Example: **12 s**, phase **30**

24.1.2.3. List of phase displays

Phase	Function
Ph00	Lockout phase
Ph02	Safety phase
Ph10	Home run
Ph12	Standby (stationary)
Ph22	Fan ramp up time (fan motor = ON, safety valve = ON)
Ph24	Traveling to the prepurge position
Ph30	Prepurge time
Ph35	Run the fan to ignition speed
Ph36	Traveling to the ignition position
Ph38	Preignition time
Ph39	Valve proving filling time (test pressure-switch-min when mounted between fuel valve V1 and fuel valve V2)
Ph40	1st safety time (ignition transformer ON)
Ph42	1st safety time (ignition transformer OFF)
Ph44	Interval 1
Ph50	2nd safety time
Ph52	Interval 2
Ph60	Operation 1 (stationary)
Ph62	Maximum time low-fire (operation 2, preparing for shutdown, traveling to low-fire)
Ph70	Afterburn time
Ph71	Run the fan to postpurge speed
Ph72	Traveling to the postpurge position
Ph74	Postpurge time (no extraneous light test)
Ph78	Postpurge time (abortion when load controller ON)
Ph79	Run the fan to standby speed
Ph80	Valve proving - test space evacuating
Ph81	Valve proving - test time atmospheric pressure
Ph82	Valve proving - test space filling
Ph83	Valve proving - test time gas pressure
Ph90	Gas shortage waiting time

24.1.3 Display of operating position

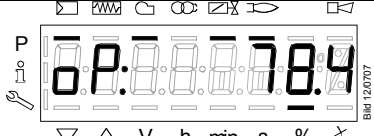

Display **oP** stands for *Operating position reached*.
Modulating mode: Current output in %

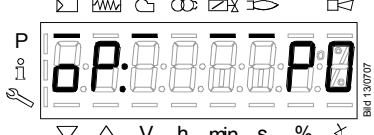

Display **oP: P0** stands for *Ignition point*.
Multistage operating mode: Current heating stage

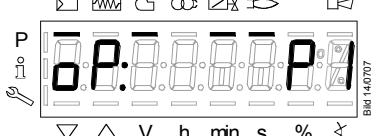

Display **oP: P1** stands for *Stage 1*.
Multistage operating mode: Current heating stage

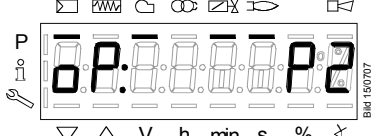

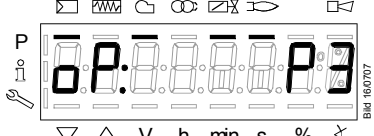

Display **oP: P2** stands for *Stage 2*.
Multistage operating mode: Current heating stage





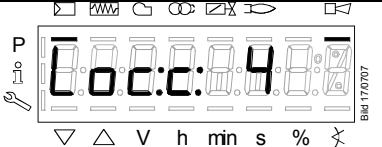

Display **oP: P3** stands for *Stage 3*.
Multistage operating mode: Current heating stage

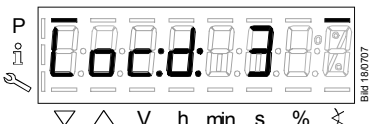
24.1.4 Fault status messages, display of errors and info





24.1.4.1. Display of errors (faults) with lockout

 i/reset 1...3 s	 Bld 170/707	<p>The display shows Loc:, the bar under the fault status message  appears.</p> <p>The LMV36 is in the lockout position.</p>
	 Bld 180/707	<p>The display shows current error code c: alternating with diagnostic code d: (refer to <i>Flash code list</i>).</p> <p>Example: Error code 4 / diagnostic code 3</p>

24.1.4.2. Reset

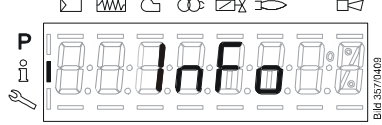
 i/reset 1...3 s	 776237/0416	<p>Press  for 1...3 s so that rESEt appears on the display.</p> <p>When you release the button, the LMV36 is reset.</p> <p>If you press  for >1 s or <1 s, the system returns to the former menu.</p> <p>Exception: If a fault occurs in connection with the curve setting, the system returns to the parameter setting level.</p>
--	--	---

24.1.4.3. Activating info / service mode from lockout

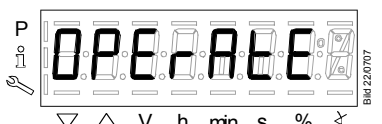
 i/reset >3 s	 Bld 357/0409	
 i/reset >5 s	 Bld 210/707	<p>Press  for >3 s so that InFo, SEr and then OPeAtE appear on the display.</p>
 i/reset >8 s	 Bld 220/707	<p>When the button is released, a change to info / service mode is made.</p>

24.1.4.4. Error with safety shutdown

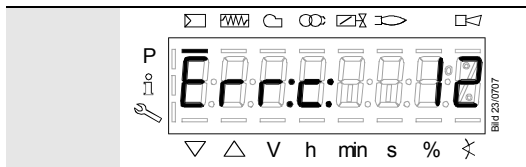

The display shows **Err:**.

The LMV36 initiates safety shutdown.

The display shows current error code **c**: alternating with diagnostic code **d**:

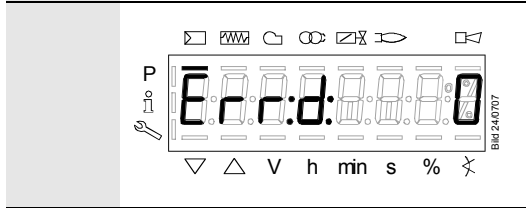

Press /reset to return to the normal display.

Example: Error code **12** / diagnostic code **0**

24.1.4.5. General information

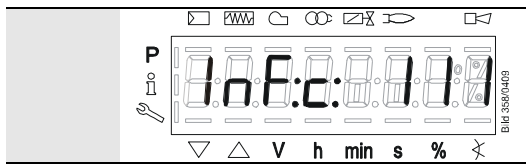

The LMV36 displays an event which does not lead to shutdown.

The display shows current error code **c**: alternating with diagnostic code **d**:

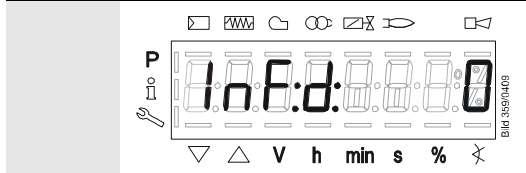

Press /reset to return to the former menu.

Example: Error code **111** / diagnostic code **0**



Note

For meaning of the error and diagnostic codes, refer to chapter *Error code list*.
When an error has been acknowledged, it can still be read out from the error history.

24.1.4.6. Prevention of startup

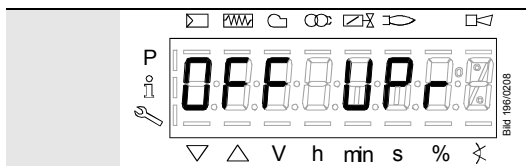

OFF UPr appears if a LMV36 was not programmed or not completely parameterized, or LMV36 operating mode was reset or changed.

The display shows **OFF UPr0** or **OFF UPr1**, depending on the type of fuel currently burnt.

24.1.4.7. Safety loop

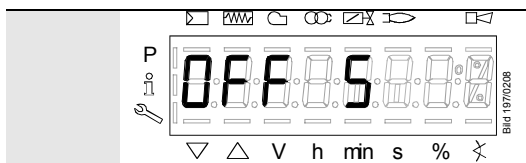

OFF S appears if a LMV36 safety loop and / or burner flange contact is open, and a load controller ON signal is present.

25 Menu-driven operation

25.1 Assignment of levels

The various levels can be accessed via different button combinations. The parameter level can only be accessed via password.

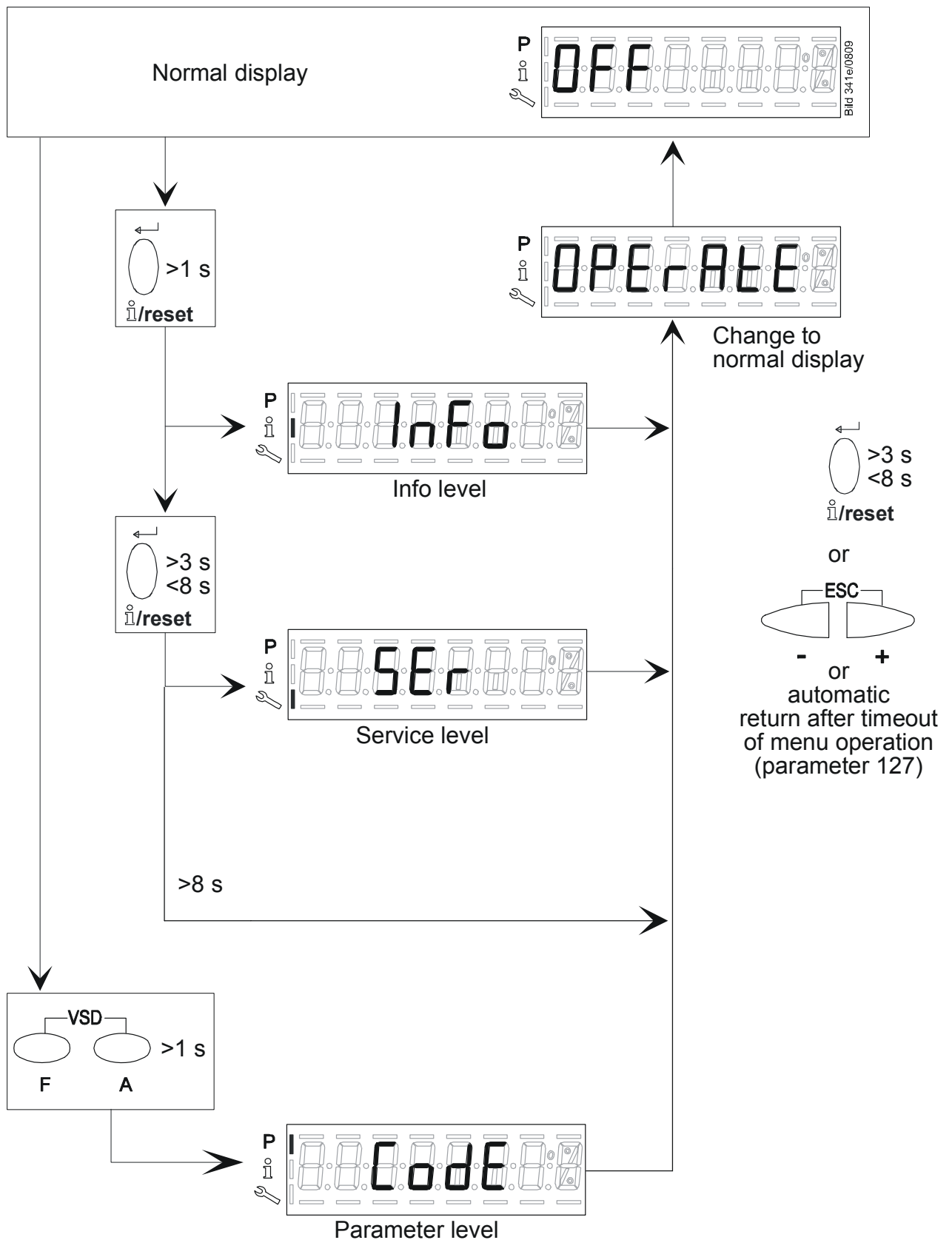
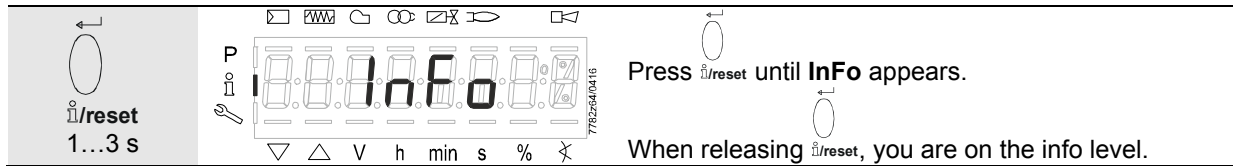

Figure 110: Assignment of levels

26 Info level

26.1 Display of info level



The info level displays information about the LMV36 and about operation in general.



Note

On the info level, you can press or to display the next or the previous parameter.

Instead of pressing , you can also press for <1 second.



Note

Press or for >8 seconds to return to the normal display.

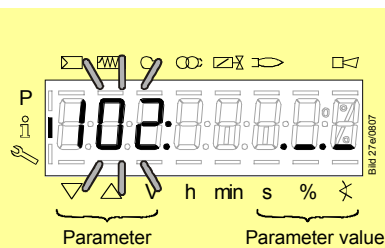

Figure 111: Info level

Note!

No change of values on the info level!

If the display shows below the parameter value, the value may consist of more than 5 digits.

The value is displayed by pressing for >1 s and <3 s.

Press for >3 s or press to return to the selection of the parameter number (parameter no. flashes).

No.	Parameter
Info level	
167	Fuel volume resettable [m ³ , l, ft ³ , gal]
162	Operating hours resettable
164	Number of startups resettable
165	Fuel 0: Number of startups
177	Fuel 1: Fuel volume resettable (m ³ , l, ft ³ , gal)
172	Fuel 1: Operation hours resettable
174	Fuel 1: Number of startups resettable
175	Fuel 1: Number of startups
163	Operating hours when LMV36 is live
166	Total number of startups
113	Burner identification
107	Software version
108	Software variant
102	Identification date
103	Identification number
104	Preselected parameter set: Customer code
105	Preselected parameter set: Version
143	Reserved
End	

26.2 Display of info values (examples)

26.2.1 Identification date

The identification date described below corresponds to the creation date for the program sequence and cannot be changed by the user.

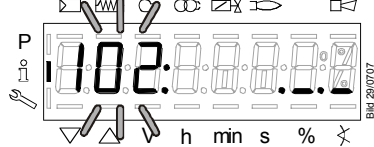

The display shows parameter **102**: flashing on the left, characters **._.** on the right.

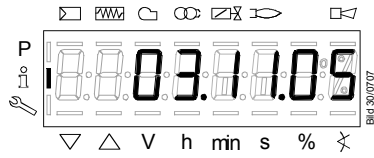

Example: **102: ._.**

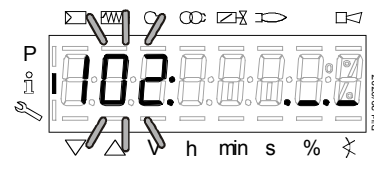

Pressing the button  (1...3 seconds) and releasing it when **._.** flashes displays the identification date (creation date of the program sequence) **DD.MM.YY**.

Example: Identification date **03.11.05**



Press the  or  button to return to the display of parameters.

To the next parameter

 +

26.2.2 Identification number

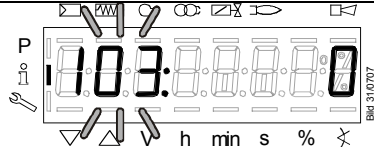

The display shows parameter **103**: flashing on the left, identification number **0** on the right.

Example: **103: 0**

To the next parameter

 +

or 

<1 s

 Back to the previous parameter

26.2.3 Burner identification

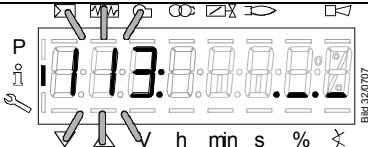

The display shows parameter **113**: flashing on the left, characters **. _ _** on the right.

Example: **113**: **. _ _**

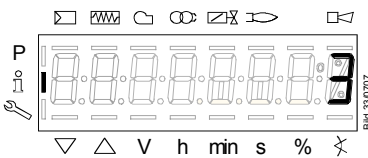

Press /reset for 1...3 s to show the burner's identification.

Default setting: **-----**

Example: **3**

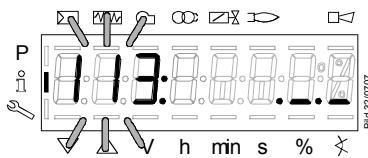

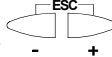
Press /reset or  to return to the display of parameters.

The burner's identification can be set on the parameter level!

To the next parameter  **+**

 **-** Back to the previous parameter

26.2.4 Number of startups resettable



Note!

Can be deleted for service refer to chapter *Parameter list*

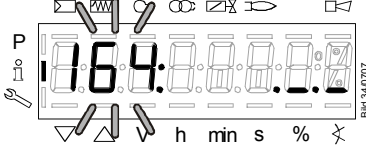



The display shows parameter **164**: flashing on the left, characters **._.** on the right, since display of the number of startups may comprise more than 5 digits.

Example: Parameter **164**: **._.**

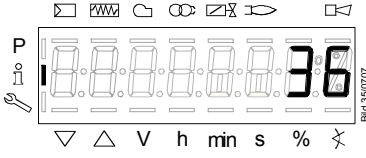

/reset
1...3 s



Pressing the button  (1...3 seconds) and releasing it when **._.** flashes displays the number of startups (can be reset).



Example: **36**

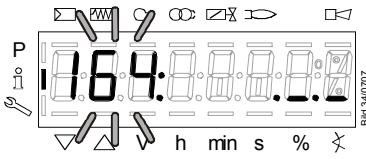

/reset
or
ESC

- +



Press  or  to show parameter **164** flashing again.

The number of startups can be reset on the parameter level!

To the next parameter



+



-

Back to the previous parameter

26.2.5 Total number of startups

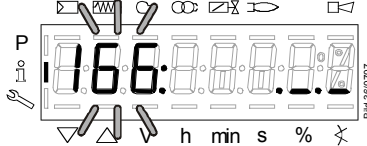

The display shows parameter **166**: flashing on the left, characters **._.** on the right, since the display of the total number of startups may comprise more than 5 digits.

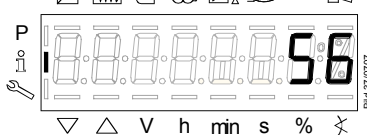

Example: Parameter **166**: **._.**

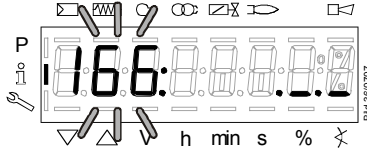

Pressing the button  (1...3 seconds) and releasing it when **._.** flashes displays the total number of startups.

Example: **56**



Press  OR  to return to the display of parameters.

26.2.6 End of info level

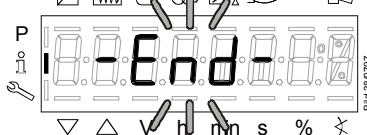

When this display appears, you have reached the end of the info level.

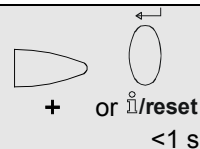

The display shows **- End -** flashing.

To the start of the info level

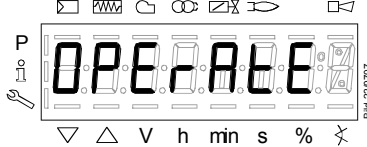

To end of info level

Press  OR  (>8 seconds) to return to the operating mode display

OPERAtE appears for a short moment.

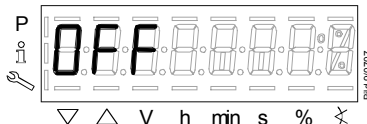

When this display appears, you are back on the normal display and you can change to the next level mode.



Press  to switch between the service and the parameter level.

27 Service level

The service level is used to display information about errors including the error history and information about the LMV36.



Note

When on the service level, you can press or to display the next or the previous parameter.

Instead of pressing , you can also press for <1 s.



Note

Press or for >3 s to return to the normal display.

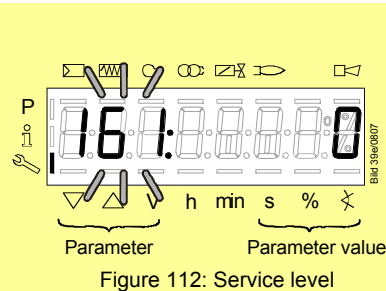

Note!

No change of values on the service level.

If characters `._._` are displayed by the parameter, the value may consist of more than 5 digits.

Press for >1 s and <3 s to display the value.

Press for >3 s or to return to the selection of the parameter number (parameter number flashes).

27.1 Display of service level

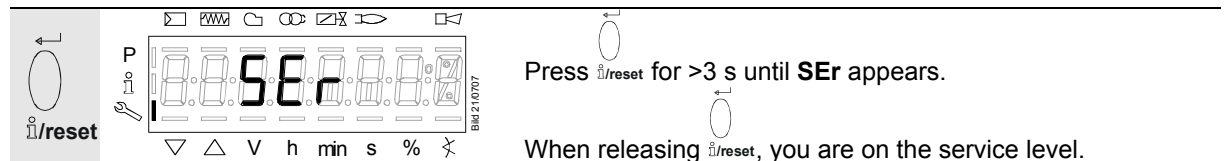

No.	Parameter
Service level	
954	Intensity of flame
960	Actual flow rate (fuel throughput in m ³ /h, l/h, ft ³ /h, gal/h)
945	Actual fuel 0 = fuel 0 1 = fuel 1
121	Manual output Undefined = automatic operation
922	Incremental position of actuators Index 0 = fuel Index 1 = air
936	Standardized speed
161	Number of faults
701	Error history: 701-725.01.Code • Error history: 701-725.02.Diagnostic code • Error history: 701-725.03.Error class • Error history: 701-725.04.Phase • Error history: 701-725.05.Startup counter • Error history: 701-725.06.Output • Error history: 701-725.07.Fuel
725	Error history: Oldest error in the history

27.2 Display of service values (example)

27.2.1 Number of faults

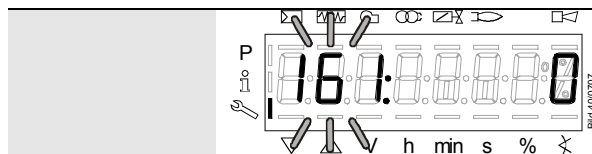

The display shows parameter **161**: flashing on the left, the number of faults that occurred thus far on the right **0**.

Example: Parameter **161: 0**

To the next parameter

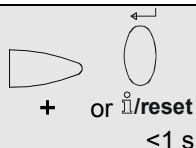

<1 s

Back to the previous parameter

27.2.2 Error history

Refer to chapter *Parameter with index, without direct display/Example of parameter 701: Error history!*



Note

Can be deleted for service (refer to chapter *Parameter list!*)

27.2.3 Intensity of flame

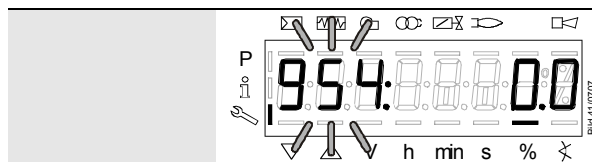

The display shows parameter **954**: flashing on the left.

On the right, the flame's intensity is displayed as a percentage.

Example: **954: 0.0**

To the next parameter

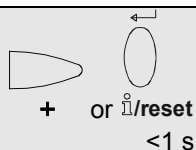

<1 s

Back to the previous parameter



Note

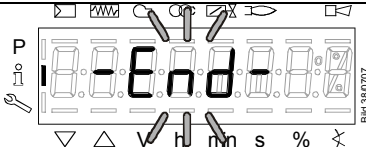

Also refer to chapter *Intensity of flame during curve settings*.

27.2.4 End of service level



The image shows a digital display with 'End' flashing. Above the display are icons for power, fan, and other system components. Below the display are navigation buttons: a downward arrow, an upward arrow, a 'V' button, 'h', 'min', 's', '%', and a crossed-out button. A wrench icon is on the left, and 'Bid 360707' is on the right.

When this display appears, you have reached the end of the service level.
Display **End** appears flashing.

To the start of the service level  +  - To the end of the service level

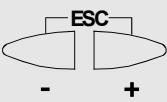

The diagram shows a button with 'ESC' written above it and '-' and '+' symbols below it.

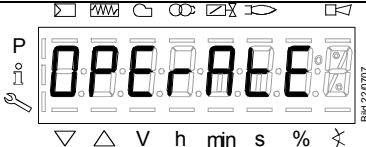

The image shows a digital display with 'OPERAtE' displayed. The layout of icons and buttons is identical to the previous display.

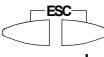
Press  to return to the normal display.
OPERAtE appears for a short moment.

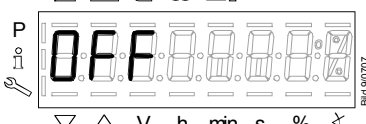

The image shows a digital display with 'OFF' displayed. The layout of icons and buttons is identical to the previous displays.

When this display appears, you are back on the normal display and you can change to the next level mode.

28 Parameter level

The parameters stored in the LMV36 can be displayed or changed on the parameter level.

The change to the parameter level requires a password.

Siemens supplies the LMV36 with the factory settings according to *Type summary*.

The OEM can change the Siemens default settings to match his own requirements.

With the LMV36, the LMV36's characteristics are determined primarily through parameter settings. Every time the unit is recommissioned, the parameter settings must be checked. The LMV36 must never be transferred from one plant to another without matching the unit's parameters to the new plant.

Caution!

Parameters and settings may only be changed by **qualified personnel**.

If parameters are changed, responsibility for the new parameter settings is assumed by the person who – in accordance with the access rights – has made parameter changes on the respective access level.

After parameterization, the OEM must check to ensure that safe burner operation is warranted.

The OEM which made the settings is always responsible for the parameters, their settings and compliance of the respective application with the relevant national and international standards and safety regulations, such as EN 267, EN 676, EN 746-2, EN 1643, etc.

Siemens, its suppliers and other Group Companies of Siemens AG do not assume responsibility for special or indirect damage, consequential damage, other damage, or damage resulting from wrong parameter settings.



Warning!

If the factory settings are changed, all changes made must be documented and checked by the OEM.

The OEM is obliged to mark the LMV36 accordingly and to include at least the list of device parameters and settings in the burner's documentation.

Siemens also recommends attaching an additional mark on the LMV36 in the form of an adhesive label. According to EN 298, the label should be easy to read and wipe proof.

The label with a maximum size of 70 mm x 45 mm can be attached to the upper part of the housing.



Example of label:

OEM logo

Type / part no.: 1234567890ABCD

Caution! OEM settings:

Parameter

225 = 30 s (t1)

226 = 2 s (t3)

230 = 10 s (t4)

234 = 0 s (t8)

240 = 1 (repetition)

257 = 2 s (t3n)

TSA = t3n + 0.7 s

259 = 30 s (t11)

260 = 30 s (t12)

28.1 Entry of password



Note

The **OEM's** password must consist of **5** characters, the **heating engineer's** of **4** characters.

		<p>Press button combination to display CodeE.</p>
		<p>When releasing the buttons, 7 bars appear the first of which flashes.</p>
		<p>Press or to select a number or letter.</p>
<p>i/reset</p>		
		<p>Press to confirm the value.</p> <p>The value entered changes to a minus sign (-).</p> <p>The next bar starts flashing.</p>
<p>i/reset</p>		
		<p>Press or to select a number or letter.</p>
<p>i/reset</p>		<p>After entry of the last character, the password must be confirmed by pressing .</p> <p>Press again to end the password entry.</p> <p>Example: Password consisting of 4 characters.</p>

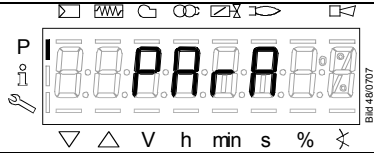

As a confirmation of correct entry, **PArA** appears for a maximum of 2 seconds.













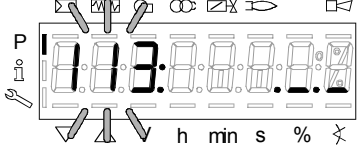



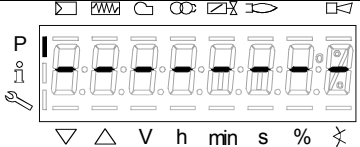
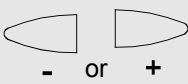
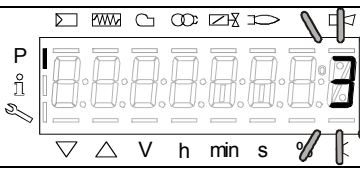

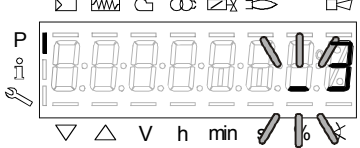

Note

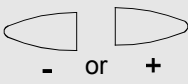
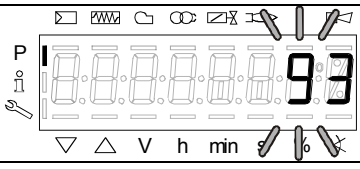
For entry of passwords or burner IDs, the following numbers and letters can be used:

	= 1		= A		= L
	= 2		= b		= n
	= 3		= C		= o
	= 4		= d		= P
	= 5		= E		= r
	= 6		= F		= S
	= 7		= G		= t
	= 8		= H		= u
	= 9		= I		= Y
	= 0		= J		

28.2 Entry of burner identification

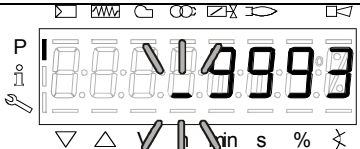
The burner's identification is entered like a password (character by character), but from right to left and ending with «_».

		<p>Parameter 113: flashes.</p> <p>Press /reset to go to editing mode.</p>
	  /reset	
		<p>You are on the display for undefined burner identification. 8 bars appear.</p>
		<p>Press  or  to select a number. Example: Number 3 flashes.</p>
	  /reset	
		<p>Press /reset to confirm the value.</p> <p>Make the entry number by number.</p>
		<p>Press  or  to select the next number. Example: Number 9 flashes.</p>
	  /reset	
  /reset	<p style="text-align: center;">• • •</p> 	<p>After entry of the last number, burner identification must be confirmed by pressing /reset.</p>

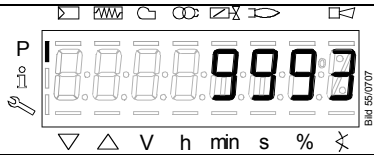

The display no longer flashes.
Example: Burner identification **9993**

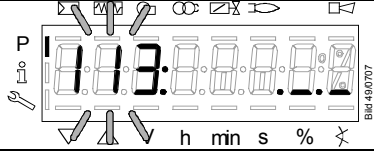
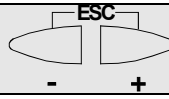

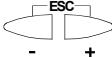
Press  to return to the parameter level.

PArAmeter 113: for burner identification.

28.3 Change of heating engineer's password



Note!

For the OEM to change the heating engineer's password, c: requires entry of the OEM password!

		<p>Press button combination to display 000: Int.</p> <p>Pressing the button takes you to parameter 041 heating engineer's password.</p>
		<p>Parameter 041: flashes.</p> <p>Press to go to level c: for password changes.</p>
		<p>Letter n: for new appears flashing.</p> <p>Proceed as described in chapter <i>Entry of password</i> and enter the new password (4 characters).</p> <p>After entry of the last character, the password must be confirmed by pressing .</p>
		<p>Letter r: for repeat appears flashing.</p> <p>Proceed as described in chapter <i>Entry of password</i> and repeat entry of the new password.</p> <p>After entry of the last character, the password must be confirmed by pressing .</p>
		<p>SEt confirms that the new password has been saved.</p>
		<p>Pressing the button takes you to parameter 041 heating engineer's password.</p>
<p>Continue in the parameter level to the next parameter group 100:</p>		<p>End of the parameter level -End-</p>

28.4 Change of OEM's password

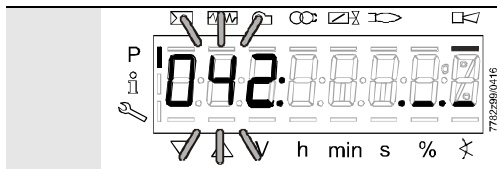

Parameter **042**: flashes.



Press  to go to level **c**: for password changes.

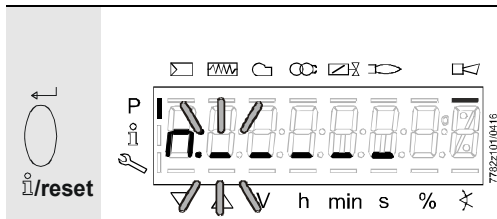

Letter **n**: for new appears flashing.

Proceed as described in chapter *Entry of password* and enter the new password (5 characters).

After entry of the last character, the password must be

confirmed by pressing .

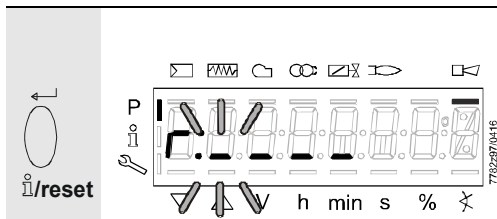

Letter **r**: for repeat appears flashing.

Proceed as described in chapter *Entry of password* and repeat entry of the new password.

After entry of the last character, the password must be

confirmed by pressing .

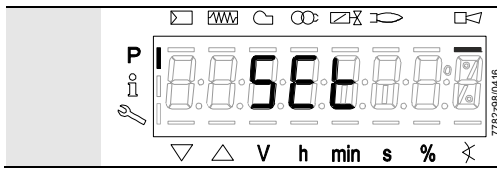

SEt confirms that the new password has been saved.

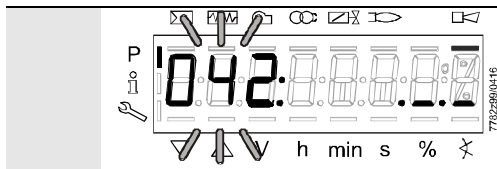







Parameter **042**: flashes again.

28.5 Use of parameter level

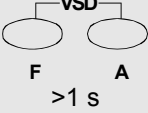
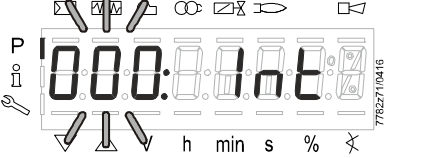
The parameters stored in the LMV36 can be displayed and changed on the parameter level.



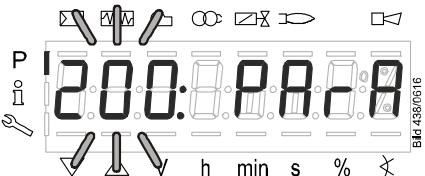





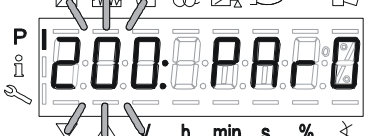

Normally, all parameters have been set by the burner manufacturer – with the exception of those for the fuel train and for fuel-air ratio control.

A description of parameter level **400**, which is used for setting the fuel train and the fuel-air ratio curve, is given in chapter *Fuel-air ratio curves – settings and commissioning*.

 <p>VSD F A >1 s</p>	 <p>776271/0416</p>	<p>Press button combination  to display 000: Int.</p> <p>With  + , select the parameter group 100: PArA.</p>
 <p>+</p>	 <p>BM 438/0516</p>	<p>With  + , select the parameter group 200: PArA.</p> <p>Pressing the  /reset button takes you to parameter 201: Burner operating mode.</p>

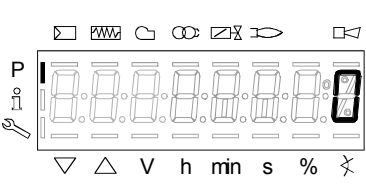
28.7 Parameters without index, with direct display

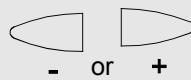
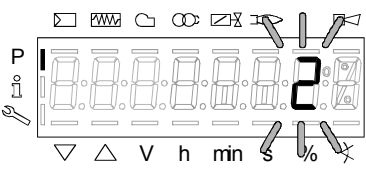
28.7.1 Using the example of parameter 208: Program stop

		<p>PArAmeter level 200: for LMV36.</p>
		<p>Press /reset to go to menu level 200:</p>
		<p>Press  + to select <i>Program stop</i>. Display: Parameter 208: flashes, value 0 does not.</p>
		
		<p>Press /reset to go to editing mode. Display: Program stop time set Here: Value 0 → corresponding to program stop deactivated.</p>
		<p>Press  - or  + to select the required program stop time.</p> <ul style="list-style-type: none"> 0 = deactivated 1 = prepurge position (phase 24) 2 = ignition position (phase 36) 3 = interval 1 (phase 44) 4 = interval 2 (phase 52) <p>Example: 2 ignition position (phase 36)</p>

Adopt the value!

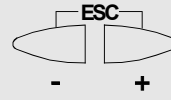
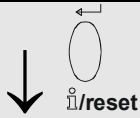

Discard the change!

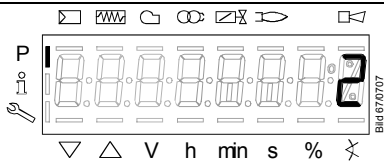

Press  to return to editing mode.

The value set is adopted.



Note

To detect potential display errors, the value is displayed 1 place shifted to the right.

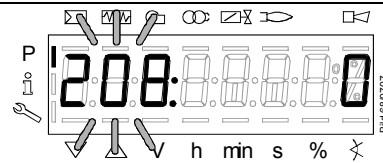

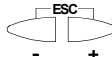
Press  - + to return to the parameter level.

Display: Parameter 208: flashes, value 0 does not.

Display: Value 2

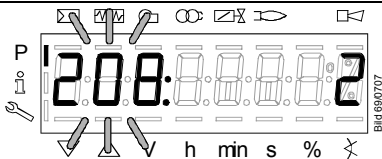
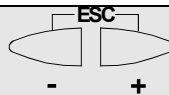

Press  - + to return to the parameter level.

PARAmeter 208: flashes, value 2 does not.

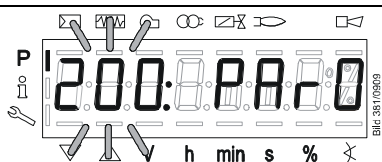
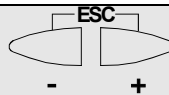

Press  - + to return to the parameter level.

PARAmeter 200: for LMV36.









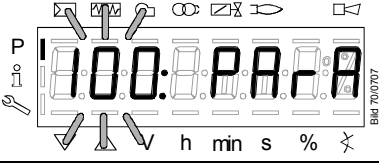

To the next parameter level

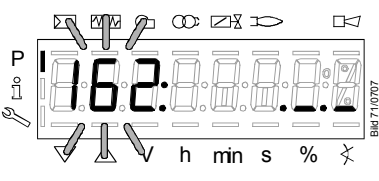

Back to the previous parameter level

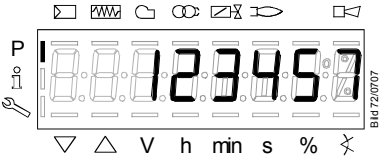
28.8 Parameters without index, with no direct display (with parameters having a value range >5 digits)

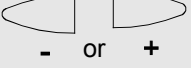
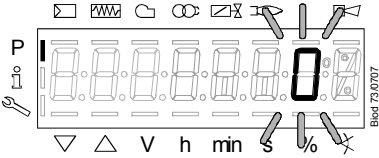
28.8.1 Using the example of parameter 162: Operating hours resettable

		<p>PArAmeter level 100: for general.</p>
		<p>Press  to go to menu level 100.</p>
		<p>Press  to select <i>Operating hours resettable</i>.</p> <p>Display: Parameter 162: flashes, characters --- do not.</p>
		
		<p>Press  to go to editing mode.</p> <p>Display: 123457</p>
		<p>You can press  or  to set the number of operating hours to 0.</p> <p>Display: Operating hours 0 flashes.</p>

Adopt the value!

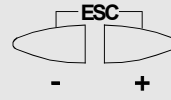
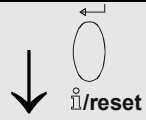

Discard the change!

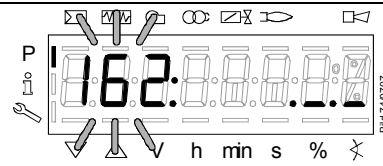
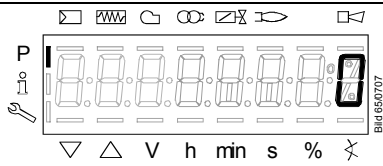



Press  to return to editing mode.

The value set will be adopted.



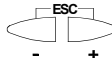



Note
To detect potential display errors, the value is displayed 1 place shifted to the right.

Press  -  +  to return to the parameter level.

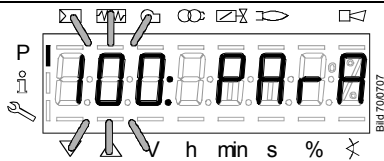
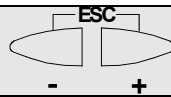
Display: Parameter **162**: flashes, characters **---** do not.

Display: Value **0**



Press  -  +  to return to the parameter level.

PARAmeter **100**: for general.

28.9 Parameter with index, with direct display

28.9.1 Using the example of parameter 501: No-flame positions fuel actuator

		<p>PARAmeter level 500: for fuel-air ratio control.</p>
		<p>Press to go to menu level 500:</p> <p>Display: Parameter 501. flashes, index 00: and value 0.0 do not.</p>
		<p>Press to go to the index.</p> <p>Display: Parameter 501. does not flash, index 00: flashes, value 0.0 does not.</p>
		<p>Press or to select the required index.</p> <ul style="list-style-type: none"> .00 = home position .01 = prepurge position .02 = postpurge position <p>Display: Index 01: for prepurge position flashes, value 0.0 does not.</p>
		<p>Press to go to editing mode.</p> <p>Display: Value 0.0</p>
		<p>Press or to select the required prepurge position.</p> <p>Example: 1.0</p>

Adopt the value!

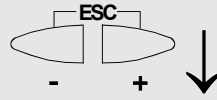
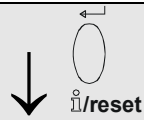

Discard the change!

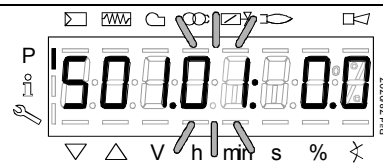
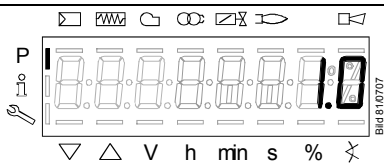

Press  to return to editing mode.

The value set will be adopted.



Note
To detect potential display errors, the value is displayed 1 place shifted to the right.

Press  to return to the index.

Display: Parameter **501**. does not flash, index **01**: flashes, value **0.0** has not changed and does not flash.

Display: Value **1.0**

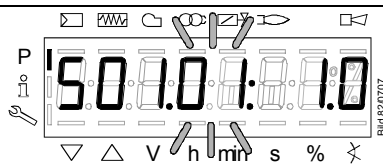
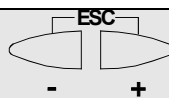

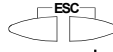
Press  to return to the index.

PARAmeter **501**: does not flash, index **01**: flashes, value **1.0** does not.

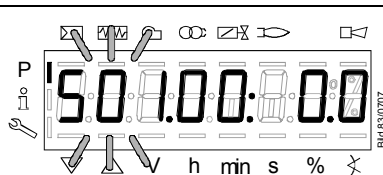
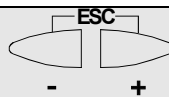

Press  to return to the parameter level.

Display: Parameter **501**. flashes, index **00**: and value **0.0** do not.

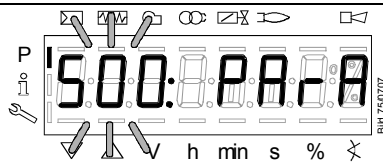
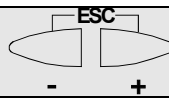

Press  to return to the parameter level.

PARAmeter **500**: for fuel-air ratio control.

28.10 Parameters with index, with no direct display

28.10.1 Using the example of parameter 701: Errors

Refer to chapter *Error code list!*



Note

Can be deleted for service, refer to chapter *Parameter list!*

HIStory 700: for error history.

Press to go to the parameter level.

Press to select parameter **701**.

Display: Parameter **701**. flashes, index **01**: and value **201** do not.

Press to go to index **01**:

Press to go to index **01**:

Display: Parameter **701**. does not flash, index **01**: flashes, value **201** does not.

To the next index Back to the previous index

Press to select the index:

- .01 = error code
- .02 = diagnostic code
- .03 = error class
- .04 = error phase
- .05 = startup counter
- .06 = output

Example:
Parameter **701**., index **05**: for startup counter, diagnostic code **1:20**

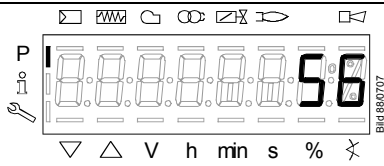

Press /reset to go to display mode.

Display: Value **56**

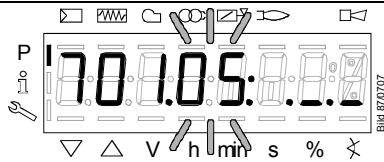
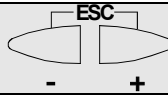

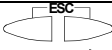
Press  - + to return to the index.

Display: Parameter **701.** does not flash, index **05:** flashes, characters **-.-** do not.

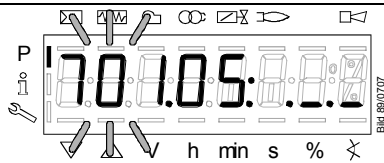
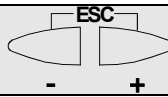

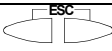
Press  - + to return to the parameter level.

Display: Parameter **701.** flashes index **05:** does not, characters **-.-** do not.

To the next older error

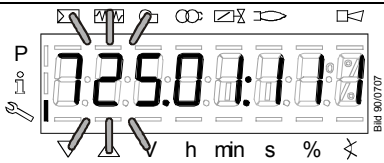

Parameters cover the period of time back to the last error since history was deleted (max. to parameter **725.**)

Example:
Parameter **725.**, index **01:**, error code **111**

To the next parameter



Back to the previous parameter

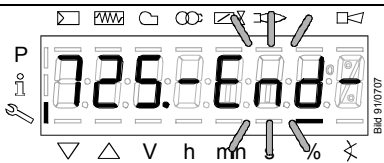

When this display appears, you have reached the end of the error history index.

Display **- End -** appears flashing.

To the next parameter

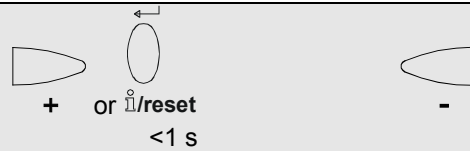

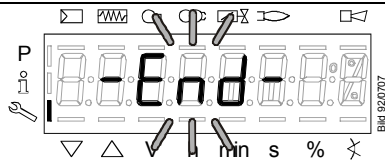

Back to the previous parameter

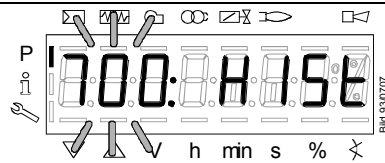
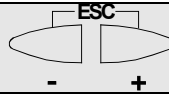

When this display appears, you have reached the end of the error history.

Display **– End –** appears flashing.



Press  to return to the parameter level.

HISt 700: for error history

To the next parameter

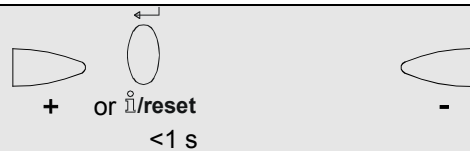

Back to the previous parameter



Note

If you wish, you can delete the error history via parameter **130**.

To delete the display, set the parameter to **1** and then to **2**.

The error history is deleted when the parameter returns to **0**.

28.11 Fuel-air ratio curves – settings and commissioning

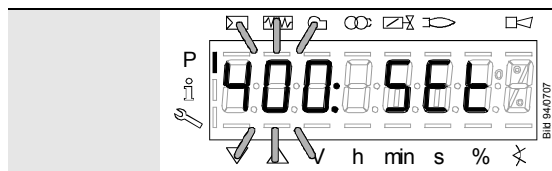

The display shows **400**: flashing on the left, **SEt** appears on the right.

28.11.1 Initial commissioning

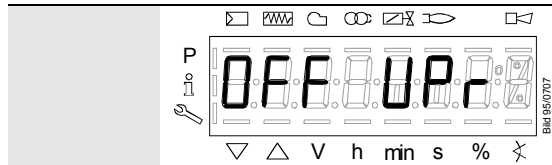

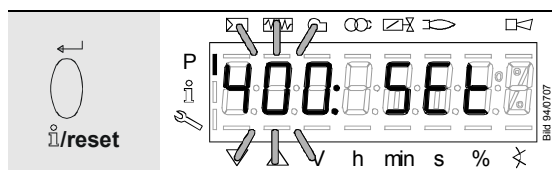

An unprogrammed LMV36 or a LMV36 whose operating mode has been reset or changed displays **OFF UPPr** or **OFF UPPr1**.

For initial commissioning, change to the parameter level (refer to chapter *Operation*).
The settings can then be made on parameter level **400**.

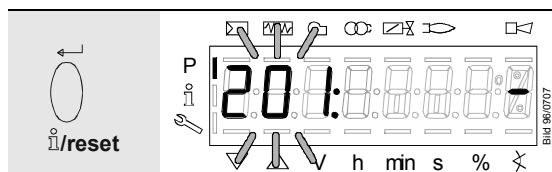

Press  to select parameter **400** for initial commissioning and for setting fuel-air ratio control.



Press  to go to the settings for fuel-air ratio control and parameter **201** for selecting the operating mode.

201: appears flashing.



Note

Ensure that the fuel train is correctly set in compliance with the type of burner used.

No.	Parameter	Actuator controlled	
		Air	Fuel
201	Burner operating mode (fuel train, modulating / multistage, actuators, etc.)	●	●
	-- = undefined (delete curves)	●	●
	1 = gas modulating (G mod)	●	●
	2 = gas modulating with pilot valve 1 (Gp1 mod)	●	●
	3 = gas modulating with pilot valve 2 (Gp2 mod)	●	●
	4 = oil modulating (Lo mod)	●	●
	5 = oil 2-stage (Lo 2 stage)	●	---
	6 = oil 3-stage (Lo 3 stage)	●	---
	7 = gas modulating pneumatic (G mod pneu)	●	---
	8 = gas modulating pneumatic with pilot valve 1 (Gp1 mod pneu)	●	---
	9 = gas modulating pneumatic with pilot valve 2 (Gp2 mod pneu)	●	---
	10 = oil modulating with pilot valve (LoGp mod)	●	●
	11 = oil 2-stage with pilot valve 2 (LoGp 2-stage)	●	---
	12 = oil modulating with 2 fuel valves (Lo mod 2 fuel valves)	●	●
	13 = oil modulating with pilot valve and 2 fuel valves (LoGp mod 2 fuel valves)	●	●
	14 = gas modulating pneumatic without actuator (G mod pneu without actuator, 0 active)	---	---
	15 = gas modulating pneumatic with pilot valve 1 without actuator (Gp1 mod pneu without actuator, 0 active)	---	---
	16 = gas modulating pneumatic with pilot valve 2 without actuator (Gp2 mod pneu without actuator, 0 active)	---	---
	17 = oil 2-stage without actuator (Lo 2-stage without actuator, 0 active)	---	---
	18 = oil 3-stage without actuator (Lo 3-stage without actuator, 0 active)	---	---
	19 = gas modulating only gas actuator (G mod only gas actuator, fuel active)	---	●
	20 = gas modulating with pilot valve 1 only gas actuator (Gp1 mod only gas actuator, fuel active)	---	●
	21 = gas modulating with pilot valve 2 only gas actuator (Gp2 mod only gas actuator, fuel active)	---	●
	22 = oil modulating only oil actuator (Lo mod only oil actuator, fuel active)	---	●
	23 = heavy oil modulating with circulation control (Ho mod separate circulation control)	●	●
	24 = heavy oil 2-stage with circulation control (Ho 2 stage separate circulation control)	●	---
	25 = heavy oil modulation without circulation control (Ho mod without circulation control)	●	●
	26 = heavy oil 2-stage without circulation control (Ho 2 stage without circulation control)	●	---
	27 = heavy oil 3-stage without circulation control (Ho 3 stage without circulation control)	●	---
28 = gas modulating mechanical only air actuator (G mod mech only fuel active, fuel active)	●	---	
29 = gas modulating mechanical with pilot valve 2 only air actuator (Gp2 mod mech only air actuator, fuel active)	●	---	

1) Selected operating mode is not released for the LMV36.

With select: Error code 210 diagnostic code 0

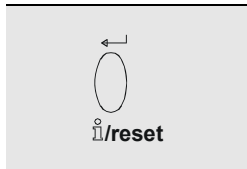

0/reset

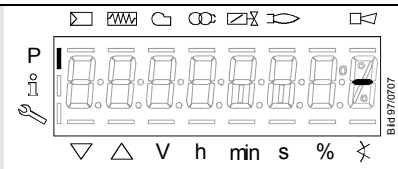

Press **0/reset** to go to editing mode.

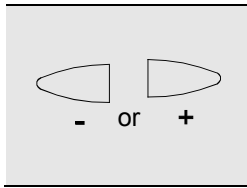

- or +

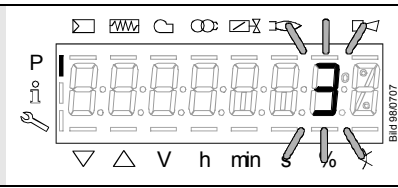

Press **-** or **+** to select the required setting.

Example: **3** for gas modulating with pilot valve (Gp2 mod)

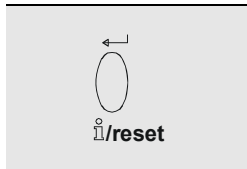

0/reset

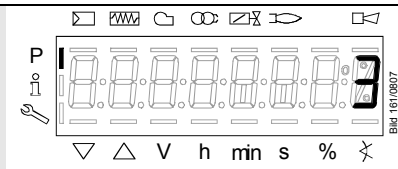

Press **0/reset** to save the selected setting.

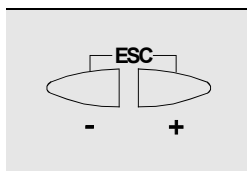

ESC

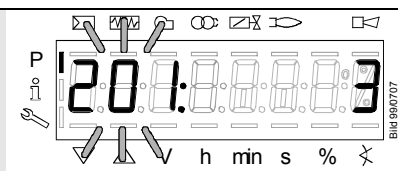

Press **- +** to return to the parameter level.

To the next parameter 

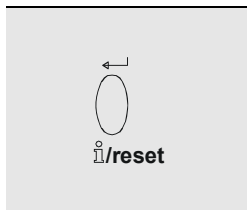

0/reset

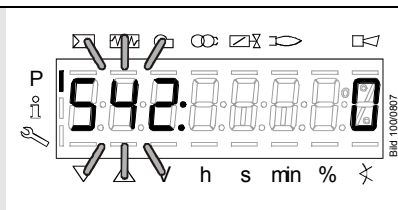

Press **0/reset** to change to parameter **542**: to activate the VSD / PWM fan.

You can choose:

- 0 = VSD / PWM fan OFF
- 1 = VSD / PWM fan ON

To the next parameter   Back to the previous parameter

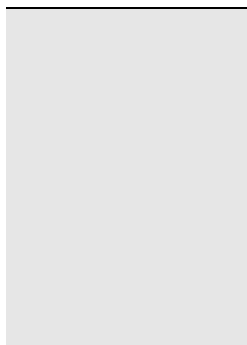

+

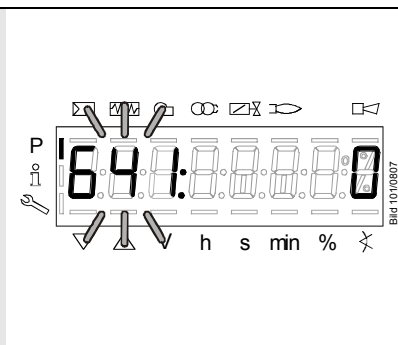

Press **+** to change to parameter **641**: to control speed standardization of the VSD.

You can choose:

- 0 = speed standardization of VSD OFF
- 1 = speed standardization of VSD ON

After setting speed standardization to **1**, standardization of the VSD commences. If successful, the parameter is reset to **0**. Negative values indicate errors (refer to chapter *Automatic speed standardization*).

To the next parameter 

- For operating modes 1...4, 7...10, 12...16 and 19...22, refer to chapter *Setting curvepoints P0 and P9 for modulating mode* («G mod», «Gp1 mod», «Gp2 mod» and «Lo mod»)
- For operating modes 5, 6, 11, 17 and 18, refer to chapter *Setting the curvepoints for multistage mode* («Lo 2-stage» and «Lo 3-stage»)

28.11.2 Setting curvepoints P0 and P9 for modulating operation («G mod», «Gp1 mod», «Gp2 mod» and «Lo mod»)



Note

Not all actuators used in the following example can be set, depending on the selected operating mode.

Example of «G mod»

		<p>Display P0 appears blinking.</p> <p>Curvepoint for ignition load.</p>
		<p>Keep F depressed.</p> <p>You are now in setting P0 of fuel setting F for ignition position P0.</p>
		<p>Press simultaneously F and - or + to set ignition position P0 of the fuel damper.</p> <p>Example: 30.0</p>
		<p>Release F.</p> <p>The selected value is adopted.</p> <p>Example: 30.0</p>
		<p>Keep A depressed.</p> <p>You are now in setting P0 of air actuator A for ignition position P0.</p>
		<p>Press simultaneously A and - or + to set ignition position P0 of the air actuator.</p> <p>Example: 22.0</p>
		<p>Release A.</p> <p>The selected value is adopted.</p> <p>Example: 22.0</p>
		<p>Keep F and A depressed.</p> <p>You are now in setting n0, speed n is for ignition position n0</p>

F and A
and
- or +

Press simultaneously **F** and **A** and **-** or **+** to adjust speed **n0** of the VSD.
Example: **20.0**

Release **F** and **A**.
The selected value is adopted.
Example: **20.0**

To the next curvepoint



Press **+**.

P9 appears blinking.
Curvepoint for high-fire.
Same procedure as with **P0**

Note!
If **-** is pressed first, the display jumps to 90!

To the next curvepoint



Back to the previous curvepoint

Press **+**.

The display shows **run** (identification of start for setting the curve parameters).
The display shows **run Gas0** or **run Gas1** or **run Oil0** or **run Oil1**, depending on the type of fuel currently burnt or the type of fuel train.

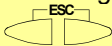

Note!

You now have the option of pressing  to proceed with the warm settings (see section *Warm settings for modulating operation* «G mod», «Gp1 mod», «Gp2 mod» and «Lo mod») or pressing  to proceed with the cold settings (see section *Cold settings for* «G mod», «Gp1 mod», «Gp2 mod» and «Lo mod») of the LMV36.

28.11.3 Setting curvepoints P0 and P9 for «G mod pneu», «Gp1 mod pneu» and «Gp2 mod pneu»



Note!

Refer to chapter *Setting curvepoints P0 and P9 for modulating operation* («G mod», «Gp1 mod», «Gp2 mod» and «Lo mod»)! Here, only the air requires adjustment with **A**.

28.11.4 Warm settings for modulating operation («G mod», «Gp1 mod», «Gp2 mod» and «Lo mod»)



Note

With the *warm settings*, the burner is started up after pressing the Info button. Air-fuel ratio control can now be accurately set while the flame is present. When traveling along the precalculated curve to high-fire point P9, all intermediate curvepoints (P2...P8) must be set. Automatic operation is released when – after reaching P9 – the curve settings are quit by pressing ESC. If the curve settings are aborted earlier (ESC or shutdown due to fault), prevention of startup OFF UPr continues to be active until all points are set. If required, the gas pressure can be set at the high-fire point. In case the gas pressure is changed, all points must be checked by traveling along the curve downward and – if required – readjusted.

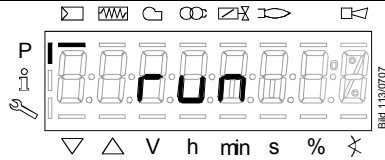

Identification of start for setting the curve parameters. The display shows **run Gas0** or **run Gas1** or **run Oil0** or **run Oil1**, depending on the type of fuel currently burnt or the type of fuel train.

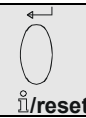

When there is a request for heat.



Note

If, during the time the curve is parameterized, an error occurs which leads to safety shutdown, parameterization of the curve is quit.

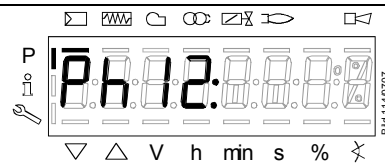

Phase *Standby* (stationary)

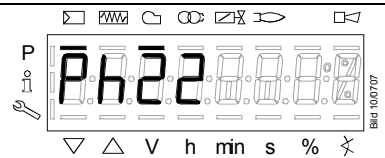

Phase *Fan ramp up*
(fan motor = ON, safety valve = ON)

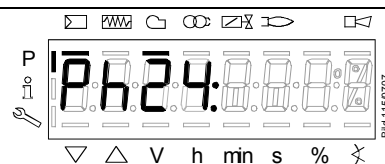

Phase *Traveling to prepurge position*

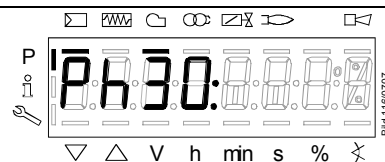

Phase *Prepurging*

Phase *Traveling to ignition position*

Wait until the burner is operating and symbol ▲ or ▼ is no longer highlighted!
 The startup sequence stops in phase 36 *Traveling to ignition position*.
 The ignition point can be adjusted under cold conditions.

Ignition position **P0** can only be set after symbol ▲ or ▼ is no longer highlighted.

For fuel, keep **F** depressed, for air **A**, as well as for VSD **F** and **A**

Press **-** or **+** to adjust the value.

When symbol ▲ or ▼ is no longer highlighted, the next curvepoint **P1** can be selected with **+**.

Phase *Traveling to ignition position*

Phase *Preignition*

Phase *1st safety time (ignition transformer ON)*

Phase *1st safety time (ignition transformer OFF), preignition time OFF*

Phase *Interval 1*

Starting the warm settings

○ or ○
F or A
and

◀ or ▶
- or +
as well as

○ and ○
F and A
and

◀ or ▶
- or +

Bild 118/0707

Ignition position **P0** can only be set when symbol ▲ or ▼ is no longer highlighted.

For fuel, keep **F** depressed, for air **A**, as well as for VSD **F** and **A**

Press **-** or **+** to adjust the value.

When symbol ▲ or ▼ is no longer highlighted, the next curvepoint **P1** can be selected with **▶**.

▶

+

▶

+

○ or ○
F or A
and

◀ or ▶
- or +
as well as

○ and ○
F and A
and

◀ or ▶
- or +

Bild 123/0707

Low-fire position **P1** can only be set when symbol ▲ or ▼ is no longer highlighted.

The value is adopted from **P0**.

For fuel, keep **F** depressed, for air **A**, as well as for VSD **F** and **A**

Press **-** or **+** to adjust the value.

When symbol ▲ or ▼ is no longer highlighted, the next curvepoint **P2** can be selected with **▶**.

To the next curvepoint

▶

+

▶

-

Back to the previous curvepoint

Bild 124/0707

When changing from **P1** to **P2** for the first time, curvepoints **P2...P8** automatically calculated and saved.

CALC appears for a short moment.

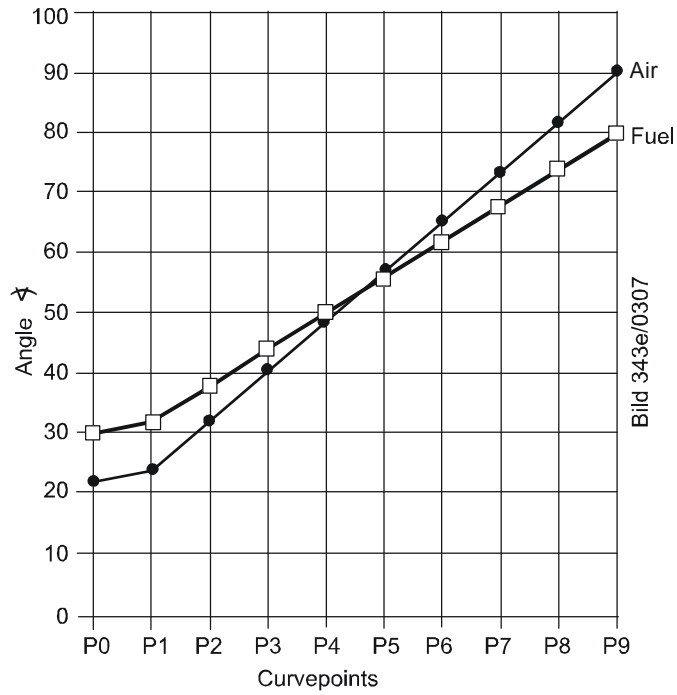

Figure 114: Setting the curvepoints



Note

Curvepoints **P2 to P8** are automatically computed as a straight line between **P1** and **P9**.

Example 1 = gas modulating

P0, P1 and **P9** are set as described:

Curvepoint	Value 1 fuel	Value 2 air
P0	30.0	22.0
P1	32.0	24.0
P9	80.0	90.0

P2 through P8 have automatically been calculated:

Curvepoint	Value 1 fuel	Value 2 air
P2	38.0	32.3
P3	44.0	40.5
P4	50.0	48.8
P5	56.0	57
P6	62.0	65.3
P7	68.0	73.5
P8	74.0	81.8

Continue the same way with P2 through P9!

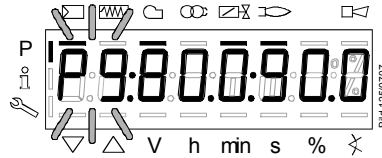
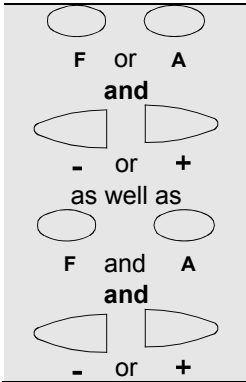

High-fire position **P9** can only be set when symbol ▲ or ▼ is no longer highlighted. If required, readjust the gas pressure.

For fuel, keep **F** depressed, for air **A**, as well as for VSD **F** and **A**

Press **-** or **+** to adjust the value. When symbol ▲ or ▼ is no longer highlighted, the next curvepoint **P8** can be selected with **-**.

After setting the high-fire (P9), either a change to parameter 546 (automatic operation) can be made (ESC) or all curvepoints can be run through in the reverse order. If the gas pressure is changed, all points must be checked and – if required – readjusted.

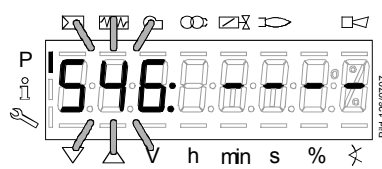
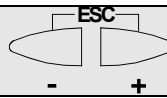

The maximum capacity is displayed. If the display shows ---, the maximum capacity has not yet been specified. The LMV36 can be run up to 100%.

You can press **reset** to go to editing mode, enabling you to change the maximum capacity.

To the next parameter

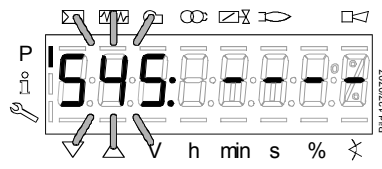

The minimum capacity is displayed. If the display shows ---, the minimum capacity has not yet been entered. The LMV36 can be run down to 20%.

You can press **reset** to go to editing mode, enabling you to change the minimum capacity.

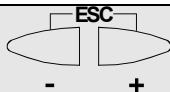

Completing parameterization of the curve



Back to the previous parameter

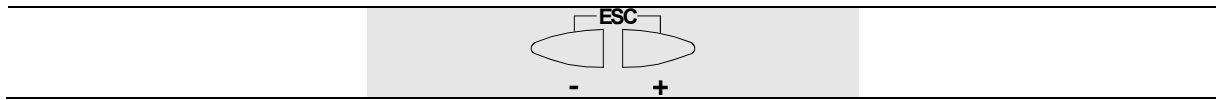
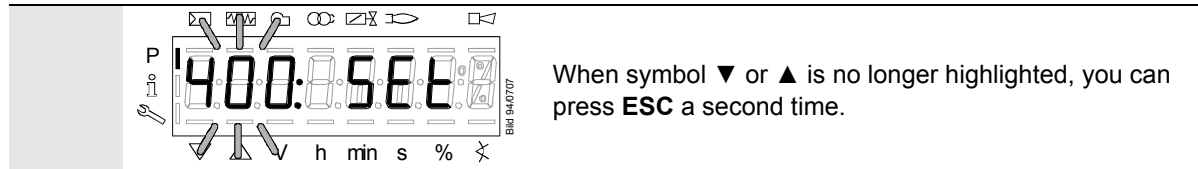

The warm settings for fuel-air ratio control by the LMV36 are now completed.

28.11.5 Warm settings for modulating mode («G mod pneu», «Gp1 mod pneu» and «Gp2 mod pneu»)

Note
 Refer to chapter *Warm settings for modulating mode («G mod», «Gp1 mod», «Gp2 mod» and «Lo mod»!* Here, only the air requires adjustment with **A**.

28.11.6 Cold settings for «G mod», «Gp1 mod», «Gp2 mod» and «Lo mod»

Note
 Refer to chapter *Warm settings for modulating mode («G mod», «Gp1 mod», «Gp2 mod» and «Lo mod»!*
 With no flame, however, no actuator travel and no automatic operation after the settings have been made.

If **run** is shown in the display, the following must be observed:

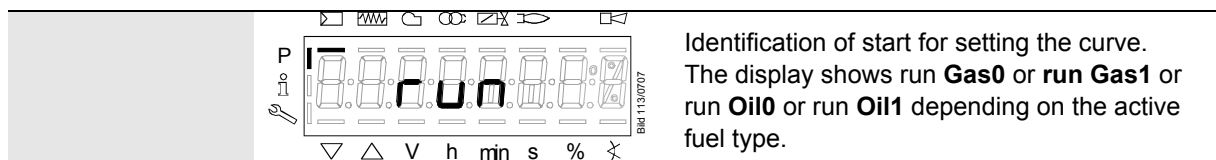

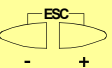
Note!
 You now have the option of pressing  to continue with the cold setting for the LMV36.

28.11.7 Cold settings for «G mod pneu», «Gp1 mod pneu» and «Gp2 mod pneu»

Note



Refer to chapter *Warm settings for modulating mode («G mod», «Gp1 mod», «Gp2 mod» and «Lo mod»!*

With no flame, however, no actuator travel and no automatic operation after the settings have been made. Here, only the air requires adjustment with .

If **run** is shown in the display, the following must be observed:

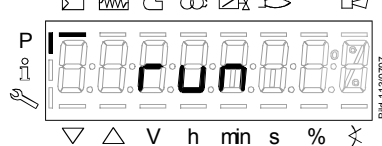

The screenshot shows a control panel display with a graph area on the left and a row of icons on the right. The graph area has a vertical axis labeled 'P' and a horizontal axis with labels 'V', 'h', 'min', 's', and '%'. The graph shows a curve that starts at a low point, rises to a peak, and then falls. The peak is labeled 'run Gas0' or 'run Gas1'. The icons on the right include a hand, a flame, a fan, a gear, a plus sign, a minus sign, and a percentage sign. The text 'BIM 1130707' is visible on the right side of the graph area.

Identification of start for setting the curve.
The display shows **run Gas0** or **run Gas1** depending on the active fuel type.

Note!



You now have the option of pressing  -  to continue with the cold setting for the LMV36.

28.11.8 Interpolation of curvepoints



Note

Changing a curvepoint in the cold position requires a new approach to all curvepoints in the warm position to verify the change on the burner itself. After changing the curvepoint, the normal display of the AZL2 shows **OFF UPr0 / OFF UPr1**.

To the next curvepoint



or



to select the curvepoint

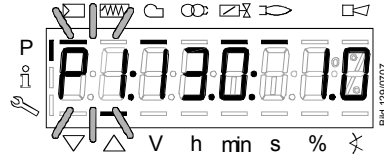

The selected curvepoint is displayed.

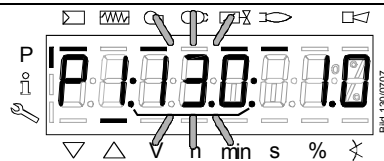

Keep **F** depressed.

The fuel actuator has been selected for changing.

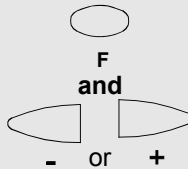

Keep **F** depressed and press **-** or **+** to adjust the fuel actuator.

In the case of warm settings, the actuator follows directly the adjustments made.

The changes are saved.

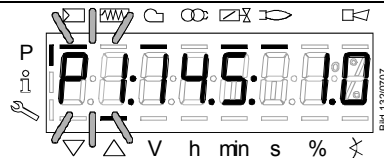

After releasing **F**, the point is selected again.



Keep **A** depressed.

The air actuator has been selected for editing.

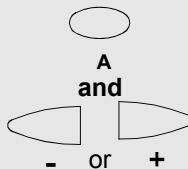

Keep **A** depressed and press **-** or **+** to adjust the air actuator.

In the case of warm settings, the actuator follows directly the adjustments made.

The changes are saved.



After releasing **A**, the point is selected again.

To the next curvepoint



Back to the previous curvepoint

28.11.9 Interpolating the curvepoints

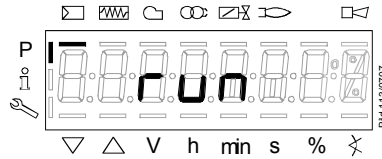
Identification of start for setting the curve parameters.

Example 1 = gas modulating

P0, P1 and P9 are set as described:	Curvepoint	Value 1 fuel	Value 2 air
	P0	30.0	22.0
	P1	32.0	24.0
	P9	80.0	90.0

P2 through P8 have automatically been calculated:	Curvepoint	Value 1 fuel	Value 2 air
	P2	38.0	32.3
	P3	44.0	40.5
	P4	50.0	48.8
	P5	56.0	57
	P6	62.0	65.3
	P7	68.0	73.5
	P8	74.0	81.8

P5 shall now be changed:

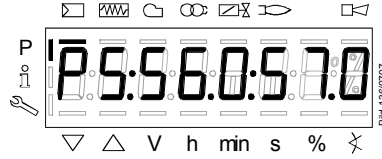
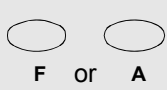
Keep **F** or **A** depressed.

Example: **F**

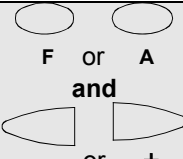

Press **-** or **+** to change the value as required.

Example: 50.0

F and A and - or +

Press - or + to change the value as required.
Example: **00.0**

F OR A

Release F OR A .
The required value is adopted.
Example: **P5:50.0:46.0**

+ >3 s

Keep + depressed for >3 s.
CALC appears.

The display jumps to **P6**.

All curvepoints from **P5 to P9** have now been automatically recalculated (linear interpolation):

Curvepoint	Value 1 fuel	Value 2 air
P5	50.0	46.0
P6	57.5	57.0
P7	65.0	68.0
P8	72.0	79.0
P9	80.0	90.0

- >3 s





Keep - depressed for >3 s.
CALC appears.

The display jumps to **P4**.

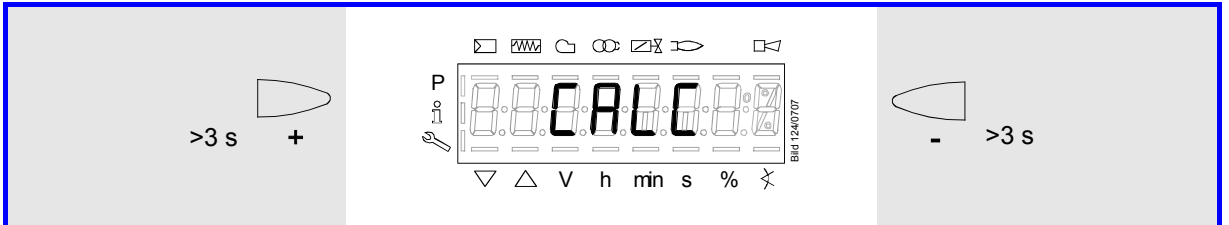
All curvepoints from **P1 to P5** have now been automatically recalculated (linear interpolation):

Curvepoint	Value 1 fuel	Value 2 air
P5	50.0	46.0
P4	45.5	40.0
P3	41.0	35.0
P2	36.5	29.5
P1	32.0	24.0



If it is not only the current curvepoint that shall be changed, but all other points in the direction of travel as well, a new straight line from the current point to **P9** (press ) or **P1** (press ) can be calculated by a long push on  or .

Display **CALC**

Example of presentation

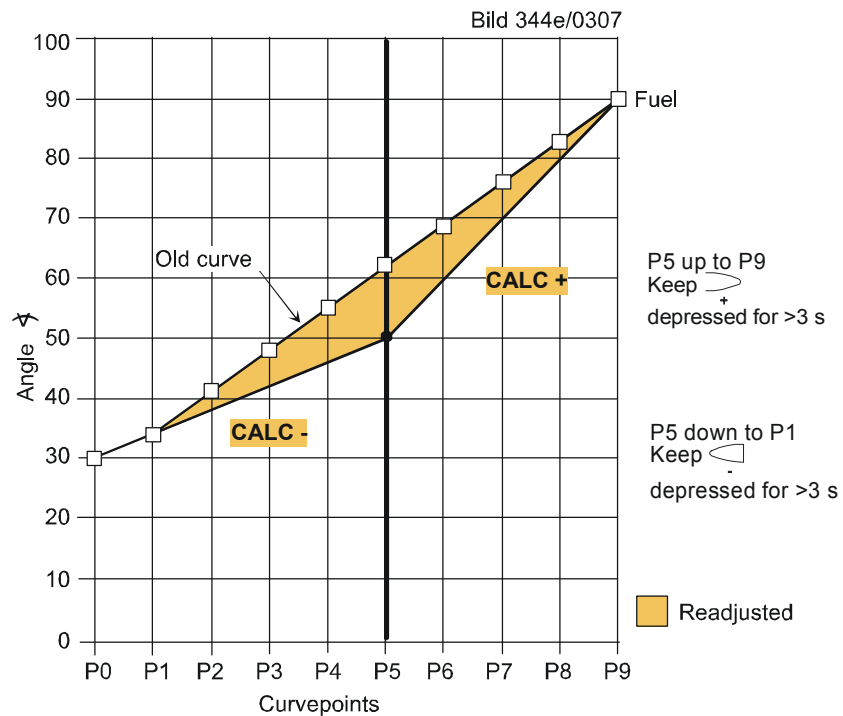

Figure 115: Changing several curvepoints



Note

Due to interpolation, a number of curvepoints change. The curvepoints changed must be approached while using the warm settings to be able to make a check on the burner. If these points have not yet been completely approached, the normal display of the AZL2 shows **OFF UPr 0 / OFF UPr1**.

28.11.10 Setting of curvepoints for multistage mode («Lo 2-stage» and «Lo 3-stage»)

Example of «Lo 2-stage»

		<p>P0 appears blinking. Curvepoint for ignition load.</p>
		<p>Keep A depressed. You are now at P0 of air actuator A.</p>
		<p>Press simultaneously A and - or + to adjust ignition position P0 of the air actuator. Example: 20.0</p>
		<p>Keep F and A depressed. You are now at n0 of the VSD.</p>
		<p>Press simultaneously F and A and - or + to adjust speed n0 of the VSD. Example: 20.0</p>
		<p>Now, release A. The selected value is adopted. Example: 20.0</p>
		<p>Identification of start for setting the curve parameters. The display shows run Oil0 or run Oil1, depending on the type of fuel currently burnt.</p>



Note!

You now have the option of pressing  to proceed with the warm settings (see section *Warm settings for modulating operation* «G mod», «Gp1 mod», «Gp2 mod»

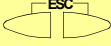
and «Lo mod») or pressing  **-** **+** to proceed with the cold settings (see section *Cold settings for* «G mod», «Gp1 mod», «Gp2 mod» and «Lo mod») of the LMV36.

28.11.11 Warm settings for «Lo 2-stage» and «Lo 3-stage»

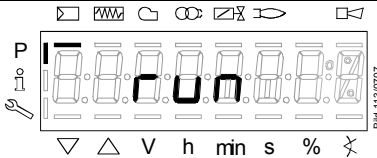

Identification of start for setting the curve parameters.
The display shows **run Oil0** or **run Oil1**, depending on the type of fuel currently burnt.



Provided the load controller is enabled!

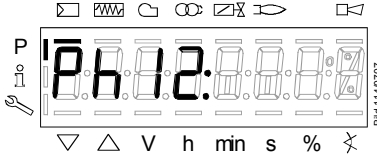

Phase *Standby* (stationary)

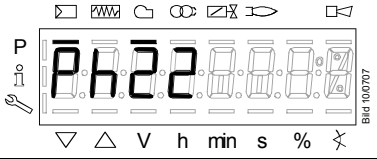

Phase *Fan ramp up*
(fan motor = ON, safety valve = ON)



Phase *Traveling to prepurge position*

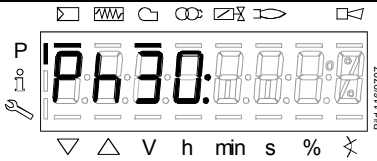

Phase *Prepurging*

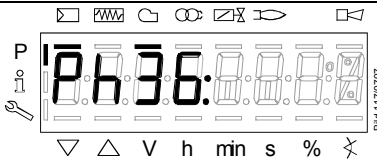

Phase *Traveling to ignition position*

Wait until the burner is operating and symbol ▲ or ▼ is no longer highlighted! The startup sequence stops in phase 36 *Traveling to ignition position*. The ignition point can be adjusted under cold conditions.

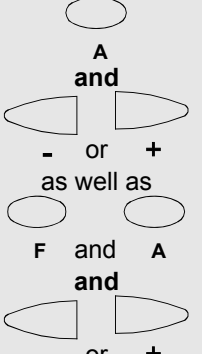
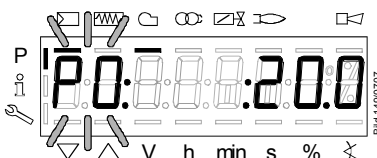



Ignition position **P0** can be set only when symbol ▲ or ▼ is no longer highlighted.

Keep **A** depressed and, for VSD **F** and **A**.

Press **-** or **+** to adjust the value.

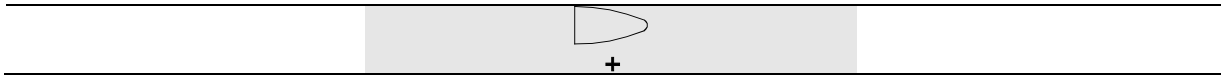
When symbol ▲ or ▼ is no longer highlighted, the next curvepoint **P1** can be selected with **+**.



Phase *Traveling to ignition position*

Phase *Preignition*

Phase *1st safety time (ignition transformer ON)*

Phase *Interval 1*

A
and

- or +
as well as

F and A
and

- or +

Ignition position **P0** can be set only when symbol ▲ or ▼ is no longer highlighted.

Keep **A** depressed and, for VSD **F** and **A**.

Press **-** or **+** to adjust the value.

When symbol ▲ or ▼ is no longer highlighted, the next curvepoint **P1** can be selected with **+**.

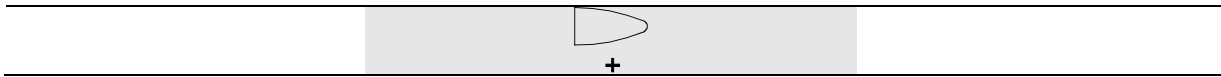

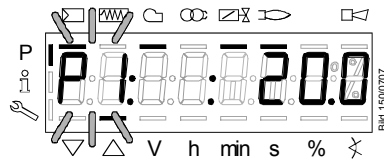
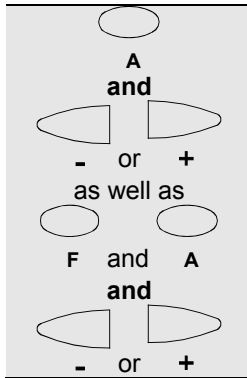

Low-fire position **P1** can be set only when symbol ▲ or ▼ is no longer highlighted. Set stage 1 **P1**. Fuel valve **V1** is switched on.

Keep **A** depressed and, for VSD **F** and **A**. Press - or + to adjust the value. When symbol ▲ or ▼ is no longer highlighted, the next curvepoint **P2on** can be selected with +.

To the next curvepoint

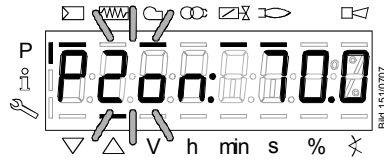
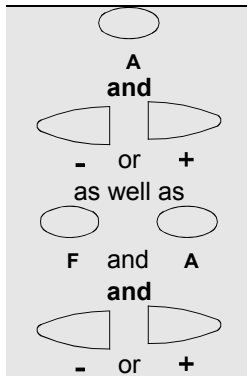

Curvepoint **P2on** can be set only when symbol ▲ or ▼ is no longer highlighted. Set switch-on point stage 2 **P2**. Fuel valve **V2** is still off.

Keep **A** depressed and, for VSD **F** and **A**. Adjust the value with - or +. When symbol ▲ or ▼ is no longer highlighted, the next curvepoint **P2_d** can be selected with +.

To the next curvepoint



Back to the previous curvepoint

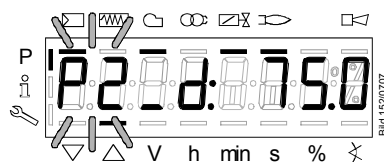
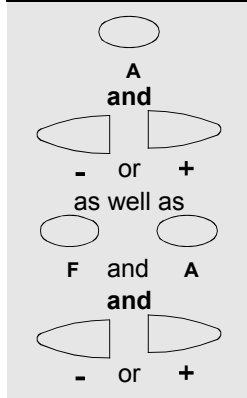

Curvepoint **P2_d** can be set only when symbol ▲ or ▼ is no longer highlighted. Fuel valve **V2** is still off and the LMV36 remains at curvepoint **P2on**. Presetting of operating stage **P2** with no travel, aimed at cutting the operating time if there is shortage of air.

Keep **A** depressed and, for VSD **F** and **A**. Press - or + to adjust the value. When symbol ▲ or ▼ is no longer highlighted, the next curvepoint **P2** can be selected with -.

To the next curvepoint



Back to the previous curvepoint

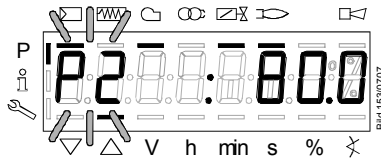
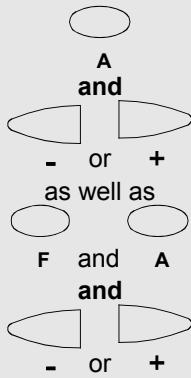

Curvepoint **P2** can only be adjusted when symbol ▲ or ▼ is no longer highlighted.

Fuel valve **V2** is switched on.

Keep **A** depressed and, for VSD **F** and **A**. Press **-** or **+** to adjust the value.

When symbol ▲ or ▼ is no longer highlighted, the next curvepoint **P2of** can be selected with **-**.

Back to the previous curvepoint

Curvepoint **P2of** is now adjusted.

The LMV36 remains at P2.

Adjust the switch-off point with no travel.

Now, the point is approached dynamically when traveling from **P2** to **P1**.

When symbol ▲ or ▼ is no longer highlighted, the next curvepoint **P1** can be selected with **-**.

To the next curvepoint



Back to the previous curvepoint

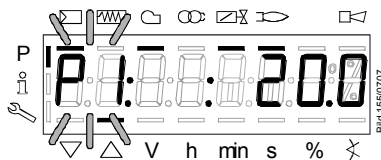

Automatic mode is released when, after reaching **P1**, the curve settings are quit with **ESC**.

If the settings are aborted earlier (**ESC** or shutdown due to fault), start prevention **OFF UPr0** or **OFF UPr1** is still active until all points are set.

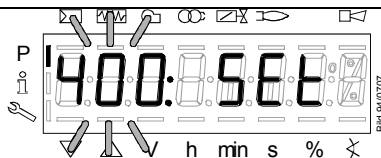
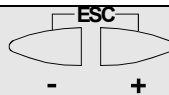

When symbol ▲ or ▼ is no longer highlighted, **ESC** can be pressed a second time.

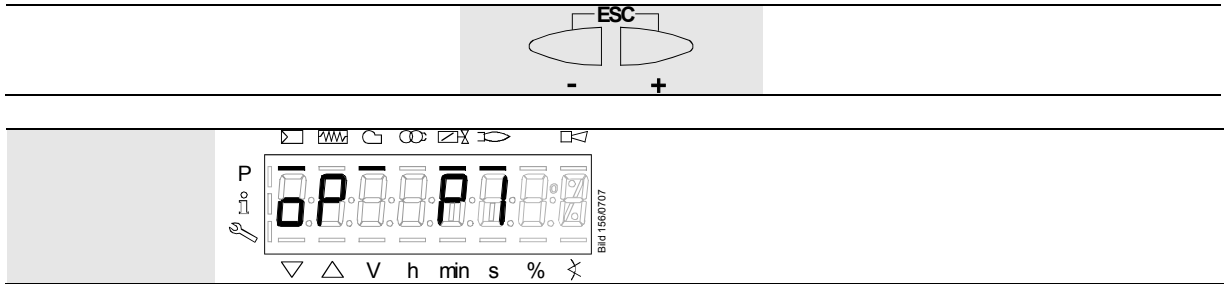

The warm settings for fuel-air ratio control of the LMV36 have now been configured.

28.11.12 Cold settings for multistage mode («Lo 2-stage» and «Lo 3-stage»)

Note
 Refer to chapters *Warm settings for «Lo 2-stage» and «Lo 3-stage»!*
 But with no flame, no actuator travel and no automatic operation after the settings have been made.

If **run** is shown in the display, the following must be observed:

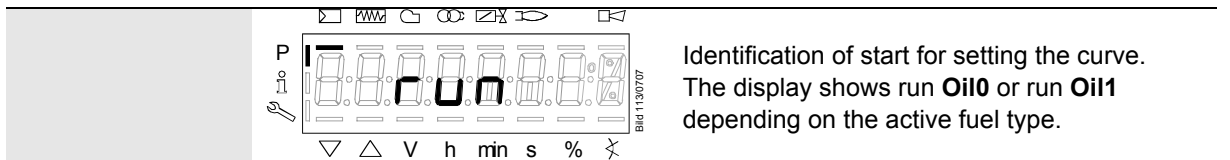

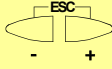
Note!
 You now have the option of pressing  to continue with the cold setting for the LMV36.

28.11.13 Intensity of flame during curve settings

When setting the curve and the curvepoint is displayed, you can press  to show the intensity of flame. When pressing the button for >1 s, a change to parameter 954 is made; when releasing the button, you return to the curvepoint.

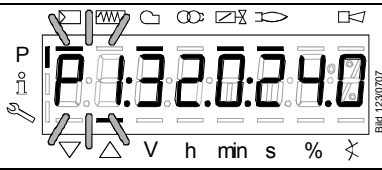

Example: Curvepoint *Low-flame position P1*.



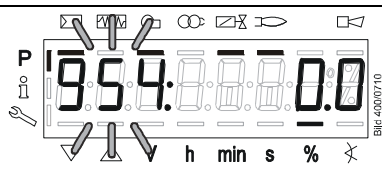

Change to parameter **954**

 >1 s



Parameter **954**: flashes.
The intensity of flame in % is shown on the right.
Example: **954: 0.0**

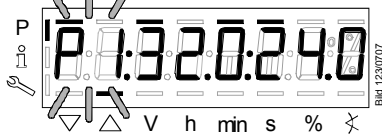

 Release  to return to curvepoint *Low-fire position P1*.

29 Parameter list for LMV36.520A1

Abbreviations for password level:

GA	Building automation
HF	Heating engineer
HF (GA)	Heating engineer (building automation)
IS	Info / service
OEM	Manufacturer of the individual product

Par. no.	Parameter	Number of elements	Type	Edit	Value range		Increment	Default setting	Password level	
					Min	Max			write	read
000	Internal parameters									
041	Password heating engineer (HF) (4 characters)	1	Std_u16	Edit	0	65535	1		OEM	OEM
042	OEM password (5 characters)	1	Std_u16	Edit	0	65535	1		OEM	OEM
050	Backup / Restore via AZL2 / PC software ACS410 starting (parameterizing on 1) Index 0 = store backup Index 1 = start restore Error diagnostic via negative value (refer to error code 137)	2	Std_s8	Edit	-99	50	1	0; 0	HF	HF
055	Burner ID of AZL2 backup data record	1	Std_s32	Read only	0	99999999	1	0	---	HF
056	ASN summary of AZL2 backup data record	8	Std_u8	Read only	0	127	1	0	---	HF
057	Software version when setting the AZL2 backup data record	1	Hex_16	Read only	0x100	0xFFFF9	1	0	---	HF
100	General									
102	Identification date	1	Date	Read only	0	255	1		---	IS
103	Identification number	1	Std_u16	Read only	0	65535	1		---	IS
104	Preselected parameter set: Customer code	1	Std_u8	Read only	0	255	1	9	---	IS
105	Preselected parameter set: Version	1	Hex_16	Read only	0	0xFFFF	1	V 01.07	---	IS
107	Software version	1	Hex_16	Read only	0x100	0xFFFF9	1	V 03.70	---	IS
108	Software variant	1	Std_u8	Read only	0	255	1	2	---	IS
111	ASN summary for verification with AZL2 backup data restore	8	Std_u8	Read only	0	127	1	0	---	HF
113	Burner identification	1	Std_s32	Edit	0	99999999	1	undefined	HF	IS
121	Manual output Undefined = automatic mode	1	Output	Edit / clear	0%	100%	0.1%	undefined	IS	IS

235/283

Par. no.	Parameter	Number of elements	Type	Edit	Value range		Increment	Default setting		Password level	
					Min	Max		Index	Value	write	read
123	Minimum output positioning step Index 0 = output building automation Index 1 = output external load controller analog Index 2 = Power of external load controller contacts	3	Output	Edit	0 %	100 %	0.1 %	Index 0 1 2	Value 0% 1% 0%	HF	HF
124	Loss of flame test (TÜV test) starting (parameterized on 1) (switch off the fuel valves → loss of flame) Error diagnostic via negative value (refer to error code 150)	1	Std_s8	Edit	-6	1	1	0		HF	HF
125	Mains frequency 0 = 50 Hz 1 = 60 Hz	1	Selection	Edit	0	1	1	0		HF	HF
126	Display brightness	1	Std_u8	Edit	0%	100%	1%	100 %		HF	HF
127	Timeout for menu operation	1	Std_u8	Edit	10 min	120 min	1 min	60 min		OEM	OEM
128	Fuel meter: Pulse valency [pulses / volume unit]	1	Std_u16	Edit	0	400	0.01	0		HF	HF
129	Fuel meter 1: Pulse valency [pulse / unit of volume]	1	Std_u16	Edit	0	400	0.01	0		HF	HF
130	Delete display of error history To delete the display: Set parameter to 1, then to 2 Return value 0: Job successfully completed Return value -1: Timeout of 1_2 sequence	1	Std_s8	Edit	-5	2	1	0		HF	HF
133	Default output at TÜV test Invalid = TÜV test at active output 20...100 = low-fire...high-fire or stage 1 / stage 2 / stage 3 P1...P3 = stage 1...stage 3	1	Output	Edit / clear	20 %	100 %	0.1 %	Undefined		HF	HF
134	Fuel 1: Default output at TÜV test Invalid = TÜV test at active output 20...100 = low-fire...high-fire or stage 1 / stage 2 / stage 3 P1...P3 = stage 1...stage 3	1	Output	Edit / clear	20 %	100 %	0.1 %	Undefined		HF	HF
141	Operating mode building automation 0 = off 1 = Modbus 2 = reserved	1	Selection	Edit	0	2	1	0		HF	HF
142	Setback time in the event of communication breakdown Setting value: 0 = deactivated 1...7200 s	1	Std_u16	Edit	0 s	7200 s	1 s	120 s		HF (GA)	HF (GA)

Par. no.	Parameter	Number of elements	Type	Edit	Value range		Increment	Default setting	Password level	
					Min	Max			write	read
143	Reserved	1	Std_u8	Edit	1	8	1	1	HF	IS
144	Reserved	1	Std_u16	Edit	10 s	60 s	1 s	30 s	HF	HF
145	Device address for Modbus of LMV36 Setting value: 1...247	1	Std_u8	Edit	1	247	1	1	HF	HF
146	Setting of Baud rate for Modbus communication 0 = 9600 1 = 19200	1	Selection	Edit	0	1	1	1	HF	HF
147	Setting of parity for Modbus communication 0 = none 1 = odd 2 = even	1	Selection	Edit	0	2	1	0	HF	HF
148	Default output if communication with building automation is interrupted Setting values For modulation operation the setting range is as follows: 0...19.9 = burner off 20...100 = 20...100% burner rating (20 = low-fire position) For multistage operation apply to setting range: 0 = burner OFF P1...P3 = stage 1...stage 3 Default setting: <i>Invalid</i>	1	Output	Edit / clear	0%	100%	0.1%	undefined	HF (GA)	HF (GA)
149	Fuel 1: Default output if communication with building automation is interrupted Setting values For modulation operation the setting range is as follows: 0...19.9 = burner off 20...100 = 20...100% burner rating (20 = low-fire position) For multistage operation apply to setting range: 0 = burner OFF P1...P3 = stage 1...stage 3	1	Output	Edit / clear	0%	100%	0.1%	undefined	HF (GA)	HF (GA)

Par. no.	Parameter	Number of elements	Type	Edit	Value range		Increment	Default setting	Password level	
					Min	Max			write	read
	Default setting: <i>Invalid</i>									
161	Number of faults	1	Std_u16	Read only	0	65535	1	0	---	IS
162	Operating hours resettable	1	Std_s32	Reset	0 h	9999999 h	1 h	0 h	IS	IS
163	Operating hours when LMV36 is live	1	Std_s32	Read only	0 h	9999999 h	1 h	0 h	---	IS
164	Number of startups resettable	1	Std_s32	Reset	0	9999999	1	0	IS	IS
165	Fuel 0: Number of startups	1	Std_s32	Read only	0	9999999	1	0	---	IS
166	Total number of startups	1	Std_s32	Read only	0	9999999	1	0	---	IS
167	Fuel volume resettable [m³, l, ft³, gal]	1	Std_s32	Reset	0	99999999	1	0	IS	IS
172	Fuel 1: Operation hours resettable	1	Std_s32	Reset	0 h	9999999 h	1 h	0 h	IS	IS
174	Fuel 1: Number of startups resettable	1	Std_s32	Reset	0	9999999	1	0	IS	IS
175	Fuel 1: Number of startups	1	Std_s32	Read only	0	9999999	1	0	---	IS
177	Fuel 1: Fuel volume resettable (m³, l, ft³, gal)	1	Std_s32	Reset	0	99999999	1	0	IS	IS
186	Software drop out delay time of flame signal (100 ms) Index 0 = QRB / QRC (0 = deactivated, >1 = activated) Index 1 = ION / QRA (0 = deactivated, >3 = activated) (only 200 ms-steps)	2	Std_u8	Edit	0	30	1	0; 0	OEM	OEM
187	Fuel 1: Software drop out delay time of flame signal (100 ms) Index 0 = QRB / QRC (0 = deactivated, >1 = activated) Index 1 = ION / QRA (0 = deactivated, >3 = activated) (only 200 ms-steps)	2	Std_u8	Edit	0	30	1	0; 0	OEM	OEM
190	Postpurging in lockout position 0 = deactivate (no-load position) 1 = active (postpurge position) When active, the <i>Alarm in the event of start prevention</i> function is only possible to a limited extent!	1	Selection	Edit	0	1	1	0	HF	HF
194	Repetition limit no flame at the end of safety time 1 = no repetition 2...4 = 1...3 repetitions Recharging time: Entering into operation	3	Std_u8	Edit	1	4	1	1	OEM	OEM
196	Repetition limit air pressure failure	1	Std_u8	Edit	1	2	1	1	OEM	OEM

Par. no.	Parameter	Number of elements	Type	Edit	Value range		Increment	Default setting	Password level	
					Min	Max			write	read
	1 = no repetition 2 = 1 repetition 3 = 2 repetitions Recharging time: End of <i>Shutdown</i> phase / 24 hours continuous operation									
197	Flame signal sensitivity setting ionization probe / QRA in operation (\geq phase 60) 0 = standard 1 = sensitivity approx. twice as high	1	Std_u8	Edit	0	1	1	0	OEM	HF
198	Maximum output for high flame sensitivity 2 = no maximum output 3...9 = P3...P9	1	Std_u8	Edit	2	9	1	4	OEM	HF
199	Repetition limit value actuators 1 = no repetition 2 = 1 repetition 3 = 2 repetitions	1	Std_u8	Edit	1	3	1	3	OEM	OEM
200	Basic unit LMV36									
201	Burner operating mode (fuel train, modulating / multistage, actuators, etc.) -- = undefined (delete curves) 1 = G mod 2 = Gp1 mod 3 = Gp2 mod 4 = Lo mod 5 = Lo 2-stage 6 = Lo 3-stage 7 = G mod pneu 8 = Gp1 mod pneu 9 = Gp2 mod pneu 10 = LoGp mod 11 = LoGp 2-stage 12 = Lo mod 2 fuel valves 13 = LoGp mod 2 fuel valves 14 = G mod pneu without actuator 15 = Gp1 mod pneu without actuator	1	Selection	Edit / clear	1	29	1	undefined	HF	HF (GA)

Par. no.	Parameter	Number of elements	Type	Edit	Value range		Increment	Default setting	Password level	
					Min	Max			write	read
	16 = Gp2 mod pneu without actuator 17 = Lo 2-stage without actuator 18 = Lo 3-stage without actuator 19 = G mod gas actuator only 20 = Gp1 mod gas actuator only 21 = Gp2 mod gas actuator only 22 = Lo mod oil actuator only 23 = Ho mod separate circulation control ¹⁾ 24 = Ho 2-stage separate circulation control ¹⁾ 25 = Ho mod. without circulation control ¹⁾ 26 = Ho 2-stage without circulation control ¹⁾ 27 = Ho 3-stage without circulation control ¹⁾ 28 = G mod mech air actuator only 29 = Gp2 mod mech air actuator only ¹⁾ Selected operating mode is not released for the LMV36: With select: Error code 210 diagnostic code 0									
204	Behavior if analog input is invalid (4...20 mA) 0 = deactivate default output low-fire / trim function (with warning message) 1 = safety shutdown + startup prevention 2 = deactivate default output low-fire / trim function (without warning message)	1	Std_u8	Edit	0	2	1	1	HF	HF
208	Program stop 0 = deactivated 1 = prepurge position (phase 24) 2 = ignition position (phase 36) 3 = interval 1 (phase 44) 4 = interval 2 (phase 52)	1	Selection	Edit	0	4	1	0	HF (GA)	HF (GA)
210	Alarm in the event of start prevention 0 = deactivated 1 = activated	1	Selection	Edit	0	1	1	1	HF	HF
211	Fan ramp up time	1	Time	Edit	2 s	60 s	0.2 s	2 s	HF	HF
212	Maximum time down to low-fire	1	Time	Edit	0.2 s	10 min	0.2 s	45 s	HF	HF
213	Waiting time home run	1	Time	Edit	2 s	60 s	0.2 s	2 s	OEM	OEM
214	Maximum time start release	1	Time	Edit	0.2 s	10 min	0.2 s	35 s	OEM	OEM

Par. no.	Parameter	Number of elements	Type	Edit	Value range		Increment	Default setting	Password level	
					Min	Max			write	read
215	Repetition limit safety loop 1 = no repetition 2...15 = 1...14 number of repetitions 16 = constant repetition Recharging time: Every 24 hours	1	Std_u8	Edit	1	16	1	1	HF	HF
217	Maximum waiting time for detection of detector or pressure switch signal (e.g. home run, preignition)	1	Time	Edit	5 s	10 min	0.2 s	30 s	OEM	OEM
221	Gas: Active detector flame evaluation 0 = QRB / QRC 1 = ION / QRA	1	Selection	Edit	0	1	1	1	HF	HF
222	Gas: Prepurging 0 = inactive 1 = active	1	Selection	Edit	0	1	1	1	HF	HF
223	Repetition limit gas pressure switch-min 1 = no repetition 2...15 = 1...14 number of repetitions 16 = constant repetition Recharging time: After the <i>Operation</i> phase  Note! Parameters 223 and 323 refer to the same value. This means that no separate setting is possible for oil / gas or fuel 0 / fuel 1.	1	Std_u8	Edit	1	16	1	1	HF	HF
225	Gas: Prepurge time	1	Time	Edit	5 s	60 min	0,2 s	30 s	HF	HF
226	Gas: Preignition time	1	Time	Edit	0.4 s	60 min	0,2 s	3 s	HF	HF
227	Gas: First safety time	1	Time	Edit	1 s	10 s	0,2 s	5 s	OEM	OEM
229	Gas: Time to respond to pressure faults within first and second safety time	1	Time	Edit	0.4 s	9.6 s	0,2 s	1,8 s	OEM	OEM
230	Gas: Interval 1	1	Time	Edit	0.4 s	60 s	0,2 s	2 s	HF	HF
231	Gas: Second safety time	1	Time	Edit	1 s	10 s	0,2 s	7 s	OEM	OEM
232	Gas: Interval 2	1	Time	Edit	0.4 s	60 s	0,2 s	2 s	HF	HF

Par. no.	Parameter	Number of elements	Type	Edit	Value range		Increment	Default setting	Password level	
					Min	Max			write	read
233	Gas: Afterburn time	1	Time	Edit	0.2 s	60 s	0.2 s	8 s	HF	HF
234	Gas: Postpurge time (no extraneous light test)	1	Time	Edit	0.2 s	108 min	0.2 s	15 s	HF	HF
235	Gas: Air pressure switch 1 = active 2 = active, except phase 60...66 / 70...72 (pneumatic operation only)	1	Selection	Edit	1	2	1	1	OEM	HF
236	Gas: Input pressure switch-min 1 = pressure switch-min before fuel valve V1 (default setting) 2 = valve proving via pressure switch-min (between fuel valve V1 and fuel valve V2) 3 = pressure switch-min after fuel valve V2	1	Selection	Edit	1	3	1	1	HF	HF
237	Gas: Input pressure switch-max / POC 1 = pressure switch-max 2 = POC 3 = pressure switch valve proving 4 = additional speed-dependent air pressure switch	1	Selection	Edit	1	4	1	1	HF	HF
239	Gas. Forced intermittent operation 0 = inactive 1 = active	1	Selection	Edit	0	1	1	1	OEM	HF
240	Repetition limit loss of flame 1 = no repetition 2 = 1 repetition Recharging time: After the <i>Operation</i> phase  Note! Parameters 240 and 280 refer to the same value. This means that no separate setting is possible for oil / gas or fuel 0 / fuel 1.	1	Std_u8	Edit	1	2	1	1	OEM	OEM
241	Gas: Execution valve proving 0 = no valve proving 1 = valve proving on startup 2 = valve proving on shutdown 3 = valve proving on startup and shutdown	1	Selection	Edit	0	3	1	0	HF	HF
242	Gas: Valve proving - test space evacuating	1	Time	Edit	0.2 s	10 s	0.2 s	3 s	OEM	OEM
243	Gas: Valve proving - test time atmospheric pressure	1	Time	Edit	0.2 s	60 s	0.2 s	10 s	OEM	OEM

242/283

Par. no.	Parameter	Number of elements	Type	Edit	Value range		Increment	Default setting	Password level	
					Min	Max			write	read
244	Gas: Valve proving - test space filling	1	Time	Edit	0.2 s	10 s	0.2 s	3 s	OEM	OEM
245	Gas: Valve proving - test time gas pressure	1	Time	Edit	0.2 s	60 s	0.2 s	10 s	OEM	OEM
246	Gas: Waiting time gas shortage	1	Time	Edit	0.2 s	60 s	0.2 s	10 s	OEM	OEM
248	Gas: Postpurge time (abortion if load controller On)	1	Time	Edit	1 s	108 min	0.2 s	1 s	HF	HF
261	Oil: Active detector of flame evaluation 0 = QRB / QRC 1 = ION / QRA	1	Selection	Edit	0	1	1	0	HF	HF
262	Oil: Prepurging 0 = inactive 1 = active	1	Selection	Edit	0	1	1	1	OEM	OEM
265	Oil: Prepurge time	1	Time	Edit	5 s	60 min	0.2 s	30 s	HF	HF
266	Oil: Preignition time	1	Time	Edit	0.6 s	60 min	0,2 s	2 s	HF	HF
267	Oil: First safety time	1	Time	Edit	1 s	15 s	0,2 s	5 s	OEM	OEM
269	Oil: Time to respond to pressure faults within first and second safety time	1	Time	Edit	0.4 s	14.6 s	0,2 s	1,8 s	OEM	OEM
270	Oil: Interval 1	1	Time	Edit	0.4 s	60 min	0,2 s	2 s	HF	HF
271	Oil: Second safety time	1	Time	Edit	1 s	15 s	0,2 s	10 s	OEM	OEM
272	Oil: Interval 2	1	Time	Edit	0.4 s	60 min	0,2 s	2 s	HF	HF
273	Oil: Afterburn time	1	Time	Edit	0.2 s	60 s	0.2 s	8 s	HF	HF
274	Oil: Postpurge time (no extraneous light test)	1	Time	Edit	0.2 s	108 min	0.2 s	15 s	HF	HF
276	Oil: Input pressure switch-min 1 = active from phase 38 2 = active from safety time	1	Selection	Edit	1	2	1	1	HF	HF
277	Oil: Input pressure switch-max/POC 1 = pressure switch-max 2 = POC 3 = not used 4 = additional speed-dependent air pressure switch	1	Selection	Edit	1	4	1	1	HF	HF
279	Oil: Forced intermittent operation 0 = inactive 1 = active	1	Selection	Edit	0	1	1	1	OEM	HF
280	Repetition limit value loss of flame 1 = no repetition 2 = 1 repetition	1	Std_u8	Edit	1	2	1	2	OEM	OEM

Par. no.	Parameter	Number of elements	Type	Edit	Value range		Increment	Default setting	Password level	
					Min	Max			write	read
	Recharging time: After the <i>Operation</i> phase  Note! Parameters 280 and 380 refer to the same value. This means that no separate setting is possible for oil / gas or fuel 0 / fuel 1.									
281	Oil: Point in time oil is ignited 0 = short preignition (phase 38) 1 = long preignition (with fan) (phase 22)	1	Selection	Edit	0	1	1	0	HF	HF
284	Oil: Postpurge time (abortion if load controller ON)	1	Time	Edit	1 s	108 min	0.2 s	1 s	HF	HF
285	Oil: gas pressure switch-min with «LoGp» 0 = inactive 1 = active	1	Selection	Edit	0	1	1	0	HF	HF
300	Basic unit LMV36									
301	Fuel 1: Burner operating mode (fuel train, modulating / multistage, actuators, etc.) -- = undefined (delete curves) 1 = G mod 2 = Gp1 mod 3 = Gp2 mod 4 = Lo mod 5 = Lo 2-stage 6 = Lo 3-stage 7 = G mod pneu 8 = Gp1 mod pneu 9 = Gp2 mod pneu 10 = LoGp mod 11 = LoGp 2-stage 12 = Lo mod 2 fuel valves 13 = LoGp mod 2 fuel valves 14 = G mod pneu without actuator 15 = Gp1 mod pneu without actuator 16 = Gp2 mod pneu without actuator	1	Selection	Edit / clear	1	29	1	Undefined	HF	HF (GA)

Par. no.	Parameter	Number of elements	Type	Edit	Value range		Increment	Default setting	Password level	
					Min	Max			write	read
	17 = Lo 2-stage without actuator 18 = Lo 3-stage without actuator 19 = G mod gas actuator only 20 = Gp1 mod gas actuator only 21 = Gp2 mod gas actuator only 22 = Lo mod oil actuator only 23 = Ho mod separate circulation control ¹⁾ 24 = Ho 2-stage separate circulation control ¹⁾ 25 = Ho mod. without circulation control ¹⁾ 26 = Ho 2-stage without circulation control ¹⁾ 27 = Ho 3-stage without circulation control ¹⁾ 28 = G mod mech air actuator only 29 = Gp2 mod mech air actuator only ¹⁾ Selected operating mode is not released for the LMV36: With select: Error code 210 diagnostic code 0									
321	Fuel 1 gas: Active detector of flame evaluation 0 = QRB / QRC 1 = ION / QRA	1	Selection	Edit	0	1	1	1	HF	HF
322	Fuel 1 gas: Prepurging 0 = inactive 1 = active	1	Selection	Edit	0	1	1	1	HF	HF
323	Repetition limit value gas pressure switch-min 1 = no repetition 2...15 = 1...14 number of repetitions 16 = constant repetition Recharging time: After the <i>Operation</i> phase  Note! Parameters 323 and 223 refer to the same value. This means that no separate setting is possible for oil / gas or fuel 0 / fuel 1.	1	Std_u8	Edit	1	16	1	1	HF	HF
325	Fuel 1 gas: Prepurge time	1	Time	Edit	5 s	60 min	0.2 s	30 s	HF	HF
326	Fuel 1 gas: Preignition time	1	Time	Edit	0.4 s	60 min	0.2 s	3 s	HF	HF

Par. no.	Parameter	Number of elements	Type	Edit	Value range		Increment	Default setting	Password level	
					Min	Max			write	read
327	Fuel 1 gas: First safety time	1	Time	Edit	1 s	10 s	0.2 s	5 s	OEM	OEM
329	Fuel 1 gas: Time to respond to pressure faults within first and second safety time	1	Time	Edit	0.4 s	9.6 s	0.2 s	1.8 s	OEM	OEM
330	Fuel 1 gas: Interval 1	1	Time	Edit	0.4 s	60 s	0.2 s	2 s	HF	HF
331	Fuel 1 gas: Second safety time	1	Time	Edit	1 s	10 s	0.2 s	7 s	OEM	OEM
332	Fuel 1 gas: Interval 2	1	Time	Edit	0.4 s	60 s	0.2 s	2 s	HF	HF
333	Fuel 1 gas: Afterburn time	1	Time	Edit	0.2 s	60 s	0.2 s	8 s	HF	HF
334	Fuel 1 gas: Postpurge time (no extraneous light test)	1	Time	Edit	0.2 s	108 min	0.2 s	15 s	HF	HF
335	Fuel 1 gas: Air pressure switch 1 = active 2 = active, except phase 60...66 / 70...72 (pneumatic operation only)	1	Selection	Edit	1	2	1	1	HF	HF
336	Fuel 1 gas: Input pressure switch-min 1 = pressure switch-min before fuel valve V1 (default setting) 2 = valve proving via pressure switch-min (between fuel valve V1 and fuel valve V2) 3 = pressure switch-min after fuel valve V2	1	Selection	Edit	1	3	1	1	HF	HF
337	Fuel 1 gas: Input pressure switch-max / POC 1 = pressure switch-max 2 = POC 3 = valve proving pressure switch 4 = additional speed-dependent air pressure switch	1	Selection	Edit	1	4	1	2	HF	HF
339	Fuel 1 gas. Forced intermittent operation 0 = inactive 1 = active	1	Selection	Edit	0	1	1	1	OEM	HF
340	Repetition limit value loss of flame 1 = no repetition 2 = 1 repetition Recharging time: After the <i>Operation</i> phase  Note! Parameters 340 and 240 refer to the same value. This means that no separate setting is possible for oil / gas or fuel 0 / fuel 1.	1	Std_u8	Edit	1	2	1	1	OEM	OEM

Par. no.	Parameter	Number of elements	Type	Edit	Value range		Increment	Default setting	Password level	
					Min	Max			write	read
341	Fuel 1 gas: Execution valve proving 0 = no valve proving 1 = valve proving on startup 2 = valve proving on shutdown 3 = valve proving on startup and shutdown	1	Selection	Edit	0	3	1	0	HF	HF
342	Fuel 1 gas: Valve proving - test space evacuating	1	Time	Edit	0.2 s	10 s	0.2 s	3 s	OEM	OEM
343	Fuel 1 gas: Valve proving - test time atmospheric pressure	1	Time	Edit	0.2 s	60 s	0.2 s	10 s	OEM	OEM
344	Fuel 1 gas: Valve proving - test space filling	1	Time	Edit	0.2 s	10 s	0.2 s	3 s	OEM	OEM
345	Fuel 1 gas: Valve proving - test time gas pressure	1	Time	Edit	0.2 s	60 s	0.2 s	10 s	OEM	OEM
346	Fuel 1 gas: Waiting time gas shortage	1	Time	Edit	0.2 s	60 s	0.2 s	10 s	OEM	OEM
348	Fuel 1 gas: Postpurge time (abortion if load controller ON)	1	Time	Edit	1 s	108 min	0.2 s	1 s	HF	HF
361	Fuel 1 oil: Active detector of flame evaluation 0 = QRB / QRC 1 = ION / QRA	1	Selection	Edit	0	1	1	1	HF	HF
362	Fuel 1 oil: Prepurging 0 = inactive 1 = active	1	Selection	Edit	0	1	1	1	OEM	OEM
365	Fuel 1 oil: Prepurge time	1	Time	Edit	5 s	60 min	0.2 s	30 s	HF	HF
366	Fuel 1 oil: Preignition time	1	Time	Edit	0.6 s	60 min	0.2 s	2 s	HF	HF
367	Fuel 1 oil: First safety time	1	Time	Edit	1 s	15 s	0.2 s	5 s	OEM	OEM
369	Fuel 1 oil: Time to respond to pressure faults within first and second safety time	1	Time	Edit	0.4 s	14.6 s	0.2 s	1.8 s	OEM	OEM
370	Fuel 1 oil: Interval 1	1	Time	Edit	0.4 s	60 min	0.2 s	2 s	HF	HF
371	Fuel 1 oil: Second safety time	1	Time	Edit	1 s	15 s	0.2 s	10 s	OEM	OEM
372	Fuel 1 oil: Interval 2	1	Time	Edit	0.4 s	60 min	0.2 s	2 s	HF	HF
373	Fuel 1 oil: Afterburn time	1	Time	Edit	0.2 s	60 s	0.2 s	8 s	HF	HF
374	Fuel 1 oil: Postpurge time (no extraneous light test)	1	Time	Edit	0.2 s	108 min	0.2 s	15 s	HF	HF
376	Fuel 1 oil: Input pressure switch-min 1 = active from phase 38 2 = active from safety time	1	Selection	Edit	1	2	1	1	HF	HF
377	Fuel 1 oil: Input pressure switch-max / POC 1 = pressure switch-max 2 = POC 3 = not used	1	Selection	Edit	1	4	1	1	HF	HF

Par. no.	Parameter	Number of elements	Type	Edit	Value range		Increment	Default setting	Password level	
					Min	Max			write	read
	4 = additional speed-dependent air pressure switch									
379	Fuel 1 oil: Forced intermittent operation 0 = inactive 1 = active	1	Selection	Edit	0	1	1	1	OEM	HF
380	Repetition limit value loss of flame 1 = no repetition 2 = 1 repetition Recharging time: After the <i>Operation</i> phase  Note! Parameters 380 and 280 refer to the same value. This means that no separate setting is possible for oil / gas or fuel 0 / fuel 1.	1	Std_u8	Edit	1	2	1	1	OEM	OEM
381	Fuel 1 oil: Point in time oil is ignited 0 = short preignition (phase 38) 1 = long preignition (with fan) (phase 22)	1	Selection	Edit	0	1	1	0	HF	HF
384	Fuel 1 oil: Postpurge time (abortion if load controller ON)	1	Time	Edit	1 s	108 min	0.2 s	1 s	HF	HF
385	Gas pressure switch-min with «LoGp» 0 = inactive 1 = active	1	Selection	Edit	0	1	1	0	HF	HF
400	Ratio curves									
401	Ratio control curves fuel actuator (curve setting only)	13	Std_s16	Edit	0 °	90 °	0.1 °	0 °; 0 °; 15 °; undefined	HF	HF
402	Ratio control curves air actuator (curve setting only)	13	Std_s16	Edit	0 °	90 °	0.1 °	0 °; 90 °; 45 °; undefined	HF	HF
403	Ratio control curves VSD (curve setting only)	13	Std_s16	Edit	10%	100%	0.1%	0%; 100%; 50%; undefined	HF	HF
404	Fuel 1: Ratio control curves fuel actuator (curve setting only)	13	Std_s16	Edit	0°	90°	0.1°	0°, 0°, 15°, undefined	HF	HF
405	Fuel 1: Ratio control curves air actuator (curve setting only)	13	Std_s16	Edit	0°	90°	0.1°	0°, 90°, 45°, undefined	HF	HF
406	Fuel 1: Ratio control curves VSD (curve setting only)	13	Std_s16	Edit	10%	100 %	0.1 %	0 %, 100 %, 50 %, undefined	HF	HF
500	Ratio control									

Par. no.	Parameter	Number of elements	Type	Edit	Value range		Increment	Default setting		Password level	
					Min	Max		Index	Value	write	read
501	No-flame positions fuel actuator Index 0 = home position Index 1 = prepurge position Index 2 = postpurge position	3	Std_s16	Edit	0 °	90 °	0.1 °	Index 0 1 2	Value 0° 0° 15°	HF	HF
502	No-flame positions air actuator Index 0 = home position Index 1 = prepurge position Index 2 = postpurge position	3	Std_s16	Edit	0 °	90 °	0.1 °	Index 0 1 2	Value 0° 90° 45°	HF	HF
503	No-flame speeds VSD Index 0 = no-load speed Index 1 = prepurge speed Index 2 = postpurge speed	3	Std_s16	Edit	0%	100%	0.1%	Index 0 1 2	Value 0% 100% 50%	HF	HF
504	Fuel 1: No-flame position fuel actuator Index 0 = home position Index 1 = prepurge position Index 2 = postpurge position	3	Std_s16	Edit	0°	90°	0.1°	0°, 0°, 15°		HF	HF
505	Fuel 1: No-flame position air actuator Index 0 = home position Index 1 = prepurge position Index 2 = postpurge position	3	Std_s16	Edit	0°	90°	0.1°	0°, 90°, 45°		HF	HF
506	Fuel 1: No-flame speed VSD Index 0 = no-load speed Index 1 = prepurge speed Index 2 = postpurge speed	3	Std_s16	Edit	0 %	100 %	0.1 %	0 %, 100 %, 50 %		HF	HF
522	Ramp up	1	Std_u8	Edit	5 s	40 s	1 s	10 s		HF	HF
523	Ramp down	1	Std_u8	Edit	5 s	40 s	1 s	10 s		HF	HF
529	Separate movement of the PWM fan (ignition speed / postpurge speed) 0 = inactive 1 = active 2 = active (50% tolerance increase outside operation)	1	Std_u8	Edit	0	2	1	0		OEM	HF
530	Activation trim function 0 = inactive 1 = active 2 = active (including test function for analog input) 3 = active (including ignition speed)	1	Std_u8	Edit	0	4	1	0		OEM	HF

Par. no.	Parameter	Number of elements	Type	Edit	Value range		Increment	Default setting	Password level	
					Min	Max			write	read
	4 = active (including ignition speed and analog input test)									
542	Activation of VSD / PWM fan 0 = deactivated 1 = activated 2 = activated (no repetition)	1	Selection	Edit	0	2	1	0	HF	HF
544	Ramp modulating	1	Std_u8	Edit	32 s	80 s	1 s	32 s	HF	HF
545	Lower output limit undefined = 20%	1	Output	Edit	20%	100%	0.1%	undefined	HF	HF (GA)
546	Upper output limit undefined = 100%	1	Output	Edit	20%	100%	0.1%	undefined	HF	HF (GA)
547	Lower trim limit	1	Std_s16	Edit	-15%	0%	0.1%	-4%	OEM	HF (GA)
548	Upper trim limit	1	Std_s16	Edit	0%	25%	0.1%	4%	OEM	HF (GA)
549	Trim damping (based on low-fire)	1	Std_u8	Edit	0%	100%	1%	88%	OEM	HF
550	Trim delay time (after entering phase 60)	1	Std_u8	Edit	0 s	255 s	1 s	25 s	OEM	HF
551	Wait time until warning with active trim limit	1	Time	Edit	0 s	60 min	0.2 s	0 s	OEM	HF
552	Behavior if maximum trim limitation time is exceeded 0 = Warning message only (trim impact remains active) 1 = Warning and deactivation of the trim function 2 = Shutdown	1	Std_u8	Edit	0	2	1	0	OEM	HF
565	Fuel 1: Lower output limit undefined = 20%	1	Output	Edit	20 %	100 %	0.1 %	Undefined	HF	HF (GA)
566	Fuel 1: Upper output limit undefined = 100%	1	Output	Edit	20 %	100 %	0.1 %	Undefined	HF	HF (GA)
567	Lower trim limit	1	Std_s16	Edit	-15%	0%	0.1%	-4%	OEM	HF (GA)
568	Upper trim limit	1	Std_s16	Edit	0%	25%	0.1%	4%	OEM	HF (GA)
569	Trim damping (based on low-fire)	1	Std_u8	Edit	0%	100%	1%	88%	OEM	HF
570	Trim delay time (after entering phase 60)	1	Std_u8	Edit	0 s	255 s	1 s	25 s	OEM	HF
571	Wait time until warning with active trim limit	1	Time	Edit	0 s	60 min	0.2 s	0 s	OEM	HF
572	Behavior if maximum trim limitation time is exceeded 0 = Warning message only (trim impact remains active) 1 = Warning and deactivation of the trim function 2 = Shutdown	1	Std_u8	Edit	0	2	1	0	OEM	HF
600	Actuators									

250/283

Par. no.	Parameter	Number of elements	Type	Edit	Value range		Increment	Default setting		Password level	
					Min	Max		Index	Value	write	read
601	Selection of reference point Index 0 = fuel Index 1 = air Setting values: 0 = CLOSED (<0°) 1 = OPEN (>90°)	2	Selection	Edit	0	1	1	Index 0 1	Value 1 0	OEM	HF
602	Actuator's direction of rotation Index 0 = fuel Index 1 = air Setting values: 0 = counterclockwise 1 = clockwise (exclusively for SQM3)	2	Selection	Edit	0	1	1	Index 0 1	Wert 0 0	OEM	HF
606	Tolerance limit of position monitoring [0.1°] Index 0 = fuel Index 1 = air Greatest position error where a fault is securely detected → error detection band: (parameter 606-0.6°) to parameter 606	2	Std_u8	Edit	0.5 °	4°	0,1°	Index 0 1	Value 1.7° 1.7°	OEM	HF
608	Fuel 1: Selection of reference point for fuel actuator 0 = CLOSED (<0°) 1 = OPEN (>90°)	1	Std_u8	Edit	0	1	1	1		OEM	HF
609	Fuel 1: Actuator's direction of rotation 0 = counterclockwise 1 = clockwise (exclusively for SQM3)	1	Std_u8	Edit	0	1	1	0		OEM	HF
610	Fuel 1: Tolerance limit of position monitoring (0.1°) for fuel actuator Greatest position error where an error is securely detected → Error detection band: (parameter 606 -0.6°) up to parameter 606	1	Std_u8	Edit	0°	4°	0.1°	1.7°		OEM	HF
611	Type of reference Index 0 = fuel Index 1 = air Setting values: 0 = standard 1 = range stop in the usable range	2	Std_u8	Edit	0	3	1	Index 0 1	Value 0 0	OEM	HF

Par. no.	Parameter	Number of elements	Type	Edit	Value range		Increment	Default setting	Password level	
					Min	Max			write	read
	2 = internal range stop (SQN1) 3 = both									
612	Fuel 1: Type of reference for fuel actuator 0 = standard 1 = range stop in the usable range 2 = internal range stop (SQN1) 3 = both	1	Std_u8	Edit	0	3	1	0	OEM	HF
613	Type of actuator Index 0 = fuel Index 1 = air Setting values: 0 = 5 s / 90° (1 Nm, 1,2 Nm, 3 Nm) 1 = 10 s / 90° (6 Nm) 2 = 17 s / 90° (10 Nm)	2	Std_u8	Edit	0	2	1	0; 0	OEM	HF
614	Fuel 1: Actuator type of the fuel 0 = 5 s / 90° (1 Nm, 1,2 Nm, 3 Nm) 1 = 10 s / 90° (6 Nm) 2 = 17 s / 90° (10 Nm)	2	Std_u8	Edit	0	2	1	0	OEM	HF
641	Activation of the speed standardization of VSD Error diagnostics of negative values (refer to error code 82) 0 = no speed standardization 1 = speed standardization active	1	Std_s8	Edit	-25	1	1	0	HF	HF
642	Standardized speed Index 0 = speed 1 Index 1 = speed 2 (internal monitoring) Fuel 1: Index 2 = speed 3 Index 3 = speed 4 (internal monitoring)	2	Std_u16	Read only	650	14000	0.1	undefined	---	HF
643	Setting the speed signal 0 = asymmetrical 1 = symmetrical	1	Selection	Edit	0	1	1	0	OEM	HF
644	Setting pulses per revolution	1	Std_u8	Edit	1	6	1	3	OEM	HF
645	Configuration of analog output 0 = DC 0...10 V 1 = DC 2...10 V	1	Std_u8	Edit	0	2	1	0	HF	HF

252/283

Par. no.	Parameter	Number of elements	Type	Edit	Value range		Increment	Default setting	Password level	
					Min	Max			write	read
	2 = DC 0/2...10 V									
647	No-load time for speed measurement in modulating operation [25 ms]	1	Std_u8	Edit	4	8	1	8	OEM	HF
652	VSD behavior when safety loop / burner flange is open 0 = no VSD control when safety loop / burner flange is open 1 = VSD control independent of safety loop / burner flange	1	Std_u8	Edit	0	1	1	1	HF	HF
653	VSD standstill supervision in standby mode 0 = deactivate 1 = active	1	Std_u8	Edit	0	1	1	1	HF	HF
661	Internal speed control of LMV36 0 = deactivated (controlled PWM fan) 1 = activated (VSD)	1	Std_u8	Edit	0	1	1	1	OEM	HF
662	Speed supervision neutral zone	1	Std_u8	Edit	0.5%	3.5%	0.1%	0.5%	OEM	HF
663	Speed supervision low deviation zone	1	Std_u8	Edit	2%	5.5%	0.1%	2%	OEM	HF
664	Speed supervision: Maximum time outside low deviation zone	1	Time	Edit	8 s	16 s	0.2 s	8 s	OEM	HF
665	Speed supervision: Maximum time outside medium deviation zone	1	Time	Edit	3 s	7 s	0.2 s	3 s	OEM	HF
667	Minimum prepurge speed	1	Std_s16	Edit / erasable	40%	100%	0.1%	undefined	OEM	HF
668	Maximum ignition speed	1	Std_s16	Edit / erasable	20%	75%	0.1%	undefined	OEM	HF
669	Minimum / maximum speed limitation in operation Index 0 = minimum speed Index 1 = maximum speed	1	Std_s16	Edit / erasable	10%	100%	0.1%	undefined	OEM	HF
670	Speed air pressure switch OFF	2	Std_s16	Edit	20%	90%	0.1%	50%	OEM	HF
671	Speed air pressure switch ON	1	Std_s16	Edit	45%	100%	0.1%	80%	OEM	HF
700	Error history									
701	Current error state									
701.01	Error code	25	Std_u8	Read only	0	255	1	0	---	IS
701.02	Diagnostic code	25	Std_u8	Read only	0	255	1	0	---	IS
701.03	Error class	25	Std_u8	Read only	0	6	1	0	---	IS
701.04	Error phase	25	Std_u8	Read only	0	255	1	0	---	IS
701.05	Startup counter	25	Std_s32	Read only	0	99999999	1	0	---	IS

Par. no.	Parameter	Number of elements	Type	Edit	Value range		Increment	Default setting	Password level	
					Min	Max			write	read
701.06	Output	25	Output	Read only	0%	100%	0.1%	0%	---	IS
701.07	Fuel	25	Std_u8	Read only	0	255	1	0	---	IS
702	Latest error in the history									
725	Oldest error in the history								---	IS
900	Process data									
903	Current output Index 0 = fuel Index 1 = air	2	Output	Read only	0%	100%	0.1%	0%	---	IS For query via ACS410
916	Input value analog input 4 mA = 15% 10 mA = 0% 20 mA = 25%	1	Std_s16	Read only	-20%	30%	0.1%	0%	---	HF (GA)
917	Target value trim function (with limitation and damping)	1	Std_s16	Read only	-17.5%	27.5%	0.1%	0%	---	HF
918	Current trim correction	1	Std_s16	Read only	-17.5%	27.5%	0.1%	0%	---	HF (GA)
922	Incremental position of actuators Index 0 = fuel Index 1 = air	2	Std_s16	Read only	-50°	150°	0.01°	0°	---	IS
932	Speed specification of the frequency converter / fan	1	Std_s16	Read only	0%	3276.7%	0.1%	0%	---	HF
933	Offset from the VSD speed control	1	Std_s16	Read only	-10%	15%	0.1%	0%	---	HF
935	Absolute speed	1	Std_u16	Read only	0	65535	1	0	---	HF (GA)
936	Standardized speed	1	Std_s16	Read only	-200%	200%	0.1%	0%	---	IS
942	Active load controller source 1 = output during curve settings 2 = manual output 3 = default output via building automation 4 = default output via analog input 5 = external load controller via contacts	1	Selection	Read only	0	255	1	0	---	HF
945	Actual fuel 0 = fuel 0 1 = fuel 1	1	Std_u8	Read only	0	255	1	0	---	IS
947	Results of contact release (bit-coded) Bit 0.0 = 1: Pressure switch-min	2	Std_u8	Read only	0	255	1	0	---	IS For query

Par. no.	Parameter	Number of elements	Type	Edit	Value range		Increment	Default setting	Password level	
					Min	Max			write	read
	Bit 0.1 = 2: Pressure switch-max Bit 0.2 = 4: Pressure switch valve proving Bit 0.3 = 8: Air pressure switch Bit 0.4 = 16: Internal fuel selection 1 Bit 0.5 = 32: Load controller ON Bit 0.6 = 64: Internal fuel selection 0 Bit 0.7 = 128: Safety loop Bit 1.0 = 1: Safety valve Bit 1.1 = 2: Ignition transformer Bit 1.2 = 4: Fuel valve V1 Bit 1.3 = 8: Fuel valve V2 Bit 1.4 = 16: Fuel valve V3 / pilot valve Bit 1.5 = 32: Reset									via ACS410
948	Contact feedback network counter register	14	Std_u8	Read only	0	255	1	0	---	HF
950	Required relay state (bit-coded) Bit 0 = 1: Alarm Bit 1 = 2: Safety valve Bit 2 = 4: Ignition Bit 3 = 8: Fuel valve V1 Bit 4 = 16: Fuel valve V2 Bit 5 = 32: Fuel valve V3 / pilot valve	1	Std_u8	Read only	0	255	1	0	---	IS For query via ACS410
951	Mains voltage (normalized) AC 230 V: Voltage = value x 1.710 AC 120 V: Voltage = value x 0.866	1	Std_u8	Read only	0 V	255 V	1 V	0 V	---	HF (GA)
954	Intensity of flame	1	Std_u8	Read only	0%	100%	1%	0%	---	IS
960	Actual flow rate (m³/h, l/h, ft³/h, gal/h)	1	Std_u16	Read only	0	6553.5	0.1	0	---	IS
961	Phase (state for external module and display)	1	Std_u8	Read only	0	255	1	0	---	IS For query via ACS410
981	Error memory: Code	1	Std_u8	Read only	0	255	1	0	---	IS For query via ACS410
982	Error memory: Diagnostic code	1	Std_u8	Read only	0	255	1	0	---	IS For query

Par. no.	Parameter	Number of elements	Type	Edit	Value range		Increment	Default setting	Password level	
					Min	Max			write	read
992	Error flags	10	Hex_32	Reset	0	0xFFFFFFFF	1	0	---	via ACS410 HF

Legend

Std_u8 8 bit integer, not signed
Std_u16 16 bit integer, not signed
Std_u32 32 bit integer, not signed
Std_s8 8 bit integer, signed



Note
This data type is also used to mark an invalid or signed values by using the value «-1».

Std_s16 16 Bit integer, signed



Note
This data type is also used to mark an invalid or signed values by using the value «-1».

Std_s32 32 Bit integer, signed





Note
This data type is also used to mark an invalid or signed values by using the value «-1».

30 Error code list (all LMV2 types / LMV3 types)

Error code	Diagnostic code	Meaning for the LMV36	Recommended measures or causes
no Comm		No communication between LMV36 and AZL2	Check wiring for line interruption/loose contact
2	#	No flame at the end of first safety time	
	1	<i>No flame at the end of first safety time</i>	
	2	<i>No flame at the end of second safety time</i>	
	4	<i>No flame at the end of first safety time (software version \leq V02.00)</i>	
3	#	Air pressure failure	
	0	<i>Air pressure off</i>	
	1	<i>Air pressure on</i>	
	2	<i>Evaluation of air pressure</i>	Correct the setting of parameter 235 or 335 (Deactivation of the air pressure check in operation only allowed in pneumatic operation!)
	4	<i>Air pressure on – prevention of startup</i>	
	20	<i>Air pressure, combustion pressure – start prevention</i>	
	68	<i>Air pressure, POC – start prevention</i>	
	84	<i>Air pressure, combustion pressure, POC – start prevention</i>	
4	#	Extraneous light	
	0	<i>Extraneous light during startup</i>	
	1	<i>Extraneous light during shutdown</i>	
	2	<i>Extraneous light during startup – prevention of startup</i>	
	6	<i>Extraneous light during startup, air pressure – start prevention</i>	
	18	<i>Extraneous light during startup, combustion pressure – start prevention</i>	
	24	<i>Extraneous light during startup, air pressure, combustion pressure – start prevention</i>	
	66	<i>Extraneous light during startup, POC – start prevention</i>	
	70	<i>Extraneous light during startup, air pressure, POC – start prevention</i>	
	82	<i>Extraneous light during startup, combustion pressure, POC – start prevention</i>	
	86	<i>Extraneous light during startup, air pressure, combustion pressure, POC – start prevention</i>	
7	#	Loss of flame	
	0	<i>Loss of flame</i>	
	3	<i>Loss of flame (software version \leq V02.00)</i>	

Error code	Diagnostic code	Meaning for the LMV36	Recommended measures or causes
	3...255	<i>Loss of flame due to TÜV test (loss-of-flame test)</i>	Diagnostics corresponds to the period of time from shutdown of fuel valves to the detection of loss of flame (increment 0.2 s → Value 5 = 1 s)
12	#	Valve proving	
	0	<i>Fuel valve V1 leaking (fuel valve V2 with valve proving via X5-01)</i>	For valve proving via X5-01 (gas pressure switch-min) - Check to see if the valve on the burner side is leaking - Check to see if the pressure switch for the valve proving is closed when gas pressure is present - Check wiring to see if there is a short-circuit
	1	<i>Fuel valve V2 leaking (fuel valve V1 with valve proving via X5-01)</i>	For valve proving via X5-01 (gas pressure switch-min) - Check to see if the valve on the gas side is leaking - Check wiring to see if there is a short-circuit
	2	<i>Valve proving not possible</i>	Valve proving activated, but pressure switch-min selected as input function for X9-04 (check parameters 238 and 241)
	3	<i>Valve proving not possible</i>	Valve proving activated, but no input assigned (check parameters 236 and 237)
	4	<i>Valve proving not possible</i>	Valve proving activated, but 2 inputs assigned (set parameter 237 to pressure switch-max or POC)
	5	<i>Valve proving not possible</i>	Valve proving activated, but 2 inputs assigned (check parameters 236 and 237)
	81	<i>V1 leaking</i>	Check to see if the valve on the gas side is leaking Check wiring to see if there is an open-circuit
	83	<i>V2 leaking</i>	Check to see if the valve on the burner side is leaking Check to see if the pressure switch for the leakage test is closed when gas pressure is present Check wiring for short-circuit. Check whether the gas pressure is present if the gas pressure switch-min was mounted after the fuel valves.
14	#	POC	
	0	<i>POC open</i>	Check to see if the valve's closing contact is closed
	1	<i>POC closed</i>	Check wiring Check to see if the valve's closing contact opens when valve is controlled
	64	<i>POC open – prevention of startup</i>	Check wiring to see if there is a line interruption. Check to see if the valve's closing contact is closed
18	#	Air pressure fault (speed-dependent air pressure switch)	
	0	<i>Air pressure off</i>	Check the setting for parameter 671. Air pressure switch (X5-02) must report an ON signal above the configured ON threshold.
	1	<i>Air pressure on</i>	Check the setting for parameter 670. Air pressure switch (X5-02) must report an OFF signal below the configured OFF threshold.
	128	<i>Invalid parameterization</i>	Check the setting of the speed thresholds (parameter 671 > 670).
19	80	<i>Combustion pressure, POC – start prevention</i>	Check to see if pressure switch has closed with no combustion pressure present Check wiring for short-circuit
20	#	Pressure switch-min	

Error code	Diagnostic code	Meaning for the LMV36	Recommended measures or causes
	0	No minimum gas / oil pressure	Check wiring for line interruption
	1	Gas shortage / prevention of startup	Check wiring for line interruption
21	#	Pressure switch-max / POC	
	0	Pressure switch-max: Max. gas / oil pressure exceeded POC: POC open (software version \leq V02.00)	Check wiring to see if there is a line interruption. POC: Check to see if the valve's closing contact is closed
	1	POC closed (software version \leq V02.00)	Check wiring. Check if the valve closure contact opens when valve is controlled.
	64	POC open –prevention of startup (software version \leq V02.00)	Check wiring. Check if the valve closure contact opens when valve is controlled.
22 OFF S	#	Safety loop / burner flange	
	0	Safety loop / burner flange open	
	1	Safety loop / burner flange open / prevention of startup	
	3	Safety loop/burner flange, extraneous light – start prevention	
	5	Safety loop/burner flange, air pressure – start prevention	
	17	Safety loop/burner flange, combustion pressure – start prevention	
	19	Safety loop/burner flange, extraneous light, combustion pressure – start prevention	
	21	Safety loop/burner flange, air pressure, combustion pressure – start prevention	
	23	Safety loop/burner flange, extraneous light, air pressure, combustion pressure – start prevention	
	65	Safety loop/burner flange, POC – start prevention	
	67	Safety loop/burner flange, extraneous light, POC – start prevention	
	69	Safety loop/burner flange, air pressure, POC – start prevention	
	71	Safety loop/burner flange, extraneous light, air pressure, POC – start prevention	
	81	Safety loop/burner flange, combustion pressure, POC – start prevention	
	83	Safety loop/burner flange, extraneous light, combustion pressure, POC – start prevention	
	85	Safety loop/burner flange, air pressure, combustion pressure, POC – start prevention	
	87	Safety loop/burner flange, extraneous light, air pressure, combustion pressure, POC – start prevention	
23	#	Gas pressure switch-min / heavy oil direct start	
	0	No minimum gas pressure	Check wiring to see if there is an open-circuit (X5-01)

Error code	Diagnostic code	Meaning for the LMV36	Recommended measures or causes
	1	<i>Gas shortage – start prevention</i>	Check wiring to see if there is an open-circuit (X5-01)
	2	<i>Heavy oil direct start</i>	Check wiring to see if there is an open-circuit (X9-04) Check that the oil is preheated correctly
50	#	Internal error	Make a reset; if error occurs repeatedly, replace the LMV36
51	#	Internal error	Make a reset; if error occurs repeatedly, replace the LMV36
55	#	Internal error	Make a reset; if error occurs repeatedly, replace the LMV36
56	#	Internal error	Make a reset; if error occurs repeatedly, replace the LMV36
57	#	Internal error	Make a reset; if error occurs repeatedly, replace the LMV36
58	#	Internal error	Make a reset; if error occurs repeatedly, replace the LMV36
60	#	Internal error: No valid load controller source	
	0	<i>Internal fault: No valid load controller source</i>	Reset; if error occurs repeatedly, replace the LMV36.
	1	<i>Analog output preset valid – prevention of startup</i>	1. Check wiring of analog predefined output to see if there is an open-circuit / loose contact. 2. LMV36.520A1: When the trim function is activated (parameter 530), the default output must not be on invalid if the Modbus communication (parameter 148 / 149) is interrupted.
	2	<i>Analog output preset valid – default output low-fire</i>	1. Check wiring of analog predefined output to see if there is an open-circuit / loose contact. 2. LMV36.520A1: When the trim function is activated (parameter 530), the default output must not be on invalid if the Modbus communication (parameter 148 / 149) is interrupted.  Note! This information is provided in connection with the thermal shock protection function (manual interruption of 4...20 mA analog input)
61 Fuel Chg	#	Fuel changeover	
<i>Fuel Chg</i>	0	<i>Fuel 0</i>	No error - change to Fuel 0
<i>Fuel Chg</i>	1	<i>Fuel 1</i>	No error - change to Fuel 1
62 Fuel Err	#	Invalid fuel signals / fuel information	
<i>Fuel Err</i>	0	<i>Invalid fuel selection (Fuel 0 + 1 = 0)</i>	Check wiring to see if there is an open-circuit  Note Curves cannot be set
<i>Fuel Err</i>	1	<i>Different fuel selection between the μCs</i>	Make a reset; if error occurs repeatedly, replace the LMV36
<i>Fuel Err</i>	2	<i>Different fuel signals between the μCs</i>	Make a reset; if error occurs repeatedly, replace the LMV36
<i>Fuel Err</i>	3	<i>Invalid fuel selection (Fuel 0 + 1 = 1)</i>	Check wiring for short-circuit  Note Curves cannot be set. LMV36: Optional press reset button >3 seconds.
65	#	Internal error	Make a reset; if error occurs repeatedly, replace the LMV36
66	#	Internal error	Make a reset; if error occurs repeatedly, replace the LMV36
67	#	Internal error	Make a reset; if error occurs repeatedly, replace the LMV36

Error code	Diagnostic code	Meaning for the LMV36	Recommended measures or causes
70	#	Internal error fuel-air ratio control: Position calculation modulating	
	23	<i>Output invalid</i>	No valid output
	26	<i>Curvepoints undefined</i>	Adjust the curvepoints for all actuators
71	#	Special position undefined	
	0	<i>Home position</i>	Parameterize the home position for all actuators used
	1	<i>Prepurge position</i>	Parameterize the prepurge position for all actuators used
	2	<i>Postpurge position</i>	Parameterize the postpurge position for all actuators used
	3	<i>Ignition position</i>	Parameterize the ignition position for all actuators used
72	#	Internal error fuel-air ratio control	Make a reset; if error occurs repeatedly, replace the LMV36
73	#	Internal error fuel-air ratio control: Position calculation multistep	
	23	<i>Output invalid</i>	No valid output
	26	<i>Curvepoints undefined</i>	Adjust the curvepoints for all actuators
75	#	Internal error fuel-air ratio control: Data clocking check	
	1	<i>Current output different</i>	Check the external load controller, including the connection. Parameters 123.1 and 123.2 must be identical (example: set to 1).
	2	<i>Target output different</i>	Check the external load controller, including the connection. Parameters 123.1 and 123.2 must be identical (example: set to 1).
	4	<i>Target positions different</i>	Check the external load controller, including the connection. Parameters 123.1 and 123.2 must be identical (example: set to 1).
	6	<i>Target output and target position different</i>	Check the external load controller, including the connection. Parameters 123.1 and 123.2 must be identical (example: set to 1).
	16	<i>Different positions reached</i>	Can be caused by different standardized speeds (e.g. after restore of data set) when the VSD is activated → standardize again and check adjustment of the fuel-air ratio control system
76	#	Internal error fuel-air control	Make a reset; if error occurs repeatedly, replace the LMV36
80	#	Control range limitation of VSD	LMV36 could not correct the difference in speed and reached a control range limit. 1. LMV36 is not standardized for this motor → repeat standardization.
			 Caution! Settings of fuel-air ratio control must be checked! 2. Ramp time settings of the VSD are not shorter than those of the LMV36 (parameters 522, 523) or the setting for the modulating operating ramp is incorrect (parameter 544) 3. Characteristic of the VSD is not linear. Configuration of the voltage input at the VSD must accord with that of the LMV36 (parameter 645). 4. VSD does not follow quickly enough the changes of the LMV36. Check settings of the VSD (input filter, slippage compensation, hiding different speeds)
	1	<i>Control range limitation at the bottom</i>	VSD speed was too high

Error code	Diagnostic code	Meaning for the LMV36	Recommended measures or causes
	2	<i>Control range limitation at the top</i>	VSD speed was too low
81	1	<i>Interrupt limitation speed input</i>	Too much electromagnetic interference on the sensor line → improve EMC
82	#	Error during VSD's speed standardization	
	1	<i>Timeout of standardization (VSD ramp down time too long)</i>	Timeout at the end of standardization during ramp down of the VSD → Ramp time settings of the VSD are not shorter than those of the LMV36 (parameter: 523)
	2	<i>Storage of standardized speed not successful</i>	Error during storage of the standardized speed → lock the LMV36, then reset it and repeat the standardization
	3	<i>Line interruption speed sensor</i>	LMV36 receives no pulses from the speed sensor: 1. Motor does not turn. 2. Speed sensor is not connected. 3. Speed sensor is not activated by the sensor disk (check distance)
	4	<i>Speed variation / VSD ramp up time too long / speed below minimum limit for standardization</i>	Motor has not reached a stable speed after ramp up. 1. Ramp time settings of the VSD are not shorter than those of the LMV36 (parameters 522, 523). 2. Characteristic of the VSD is not linear. Configuration of the voltage input at the VSD must accord with that of the LMV36 (parameter 645). 3. VSD does not follow quickly enough the changes of the LMV36. Check settings of the VSD (input filter, slippage compensation, hiding different speeds) 4. Speed of VSD lies below the minimum for standardization (650 1/min)
	5	<i>Wrong direction of rotation</i>	Motor's direction of rotation is wrong. 1. Motor turns indeed in the wrong direction → change parameterization of the direction of rotation or interchange 2 live conductors. 2. Sensor disk is fitted the wrong way → turn the sensor disk.
	6	<i>Unplausible sensor signals</i>	The required pulse pattern (60°, 120°, 180°) has not been correctly identified. 1. Speed sensor does not detect all tappets of the sensor disk → check distance 2. As the motor turns, other metal parts are detected also, in addition to the tappets → improve mounting. 3. Electromagnetic interference on the sensor lines → check cable routing, improve EMC 4. Checking the settings for parameters 643 (symmetry) and 644 (number of pulses per revolution)
	7	<i>Invalid standardized speed</i>	The standardized speed measured does not lie in the permissible range. → Motor turns too slowly or too fast.
	15	<i>Speed deviation $\mu C1 + \mu C2$</i>	The speeds of microcomputer 1 and 2 deviated too much. This can be caused by wrong standardized speeds (e.g. after restoring a data set to a new LMV36) → repeat standardization and check the fuel-air ratio

Error code	Diagnostic code	Meaning for the LMV36	Recommended measures or causes
	20	<i>Wrong phase of phase manager</i>	Standardization was made in a wrong phase. Permitted are only phases ≤ 12 → load controller OFF, start standardization again
	21	<i>Safety loop / burner flange open</i>	Safety loop or burner flange is open → repeat standardization with safety loop closed
	22	<i>Air actuator not referenced</i>	Air actuator has not been referenced or has lost its referencing. 1. Check if the reference position can be approached. 2. Check if actuators have been mixed up. 3. If error only occurs after the start of standardization, the actuator might be overloaded and cannot reach its destination.
	23	<i>VSD deactivated</i>	Standardization was started with VSD deactivated → activate the VSD and repeat standardization
	24	<i>No valid operation mode</i>	Standardization was started without valid operation mode → activate valid operation mode and repeat standardization
	25	<i>Pneumatic air-fuel ratio control</i>	Standardization was started with pneumatic air-fuel ratio control → standardization with pneumatic air-fuel ratio control not possible  Attention! If speed supervision is required in the pneumatic ratio control, the relevant parameters must be set (parameters 667 / 668 / 669) before standardization.
	128	<i>Running command with no preceding standardization</i>	VSD is controlled but not standardized → make standardization
	255	<i>No standardized speed available</i>	Motor turns but is not standardized → make standardization
83	#	Speed error VSD	Required speed has not been reached
	0	<i>Speed error when trim function is active</i>	Increase parameter 662 (neutral zone in speed supervision) and parameter 663 (close range in speed supervision)
	Bit 0 Valency 1	<i>Lower control range limitation of control</i>	Speed has not been reached because control range limitation has become active → for measures, refer to error code 80
	Bit 1 Valency 2...3	<i>Upper control range limitation of control</i>	Speed has not been reached because control range limitation has become active → for measures, refer to error code 80
	Bit 2 Valency 4...7	<i>Interruption via disturbance pulses</i>	Speed has not been reached due to too much electromagnetic interference on the sensor line → for measures, refer to error code 81
	Bit 3 Valency ≥ 8	<i>Curve too steep in terms of ramp speed</i>	Check speed differential between the curvepoints and the modulating operating ramp setting (parameter 544). 1. Modulating operating ramp 32 seconds Curve slope max. 10% for LMV36 ramp of 20 seconds (20% for 10 seconds or 40% for 5 seconds) 2. Modulating operating ramp 48 seconds Curve slope max. 10% for LMV36 ramp of 30 seconds (20% for 15 seconds or 30% for 10 seconds)

Error code	Diagnostic code	Meaning for the LMV36	Recommended measures or causes
			<p>3. Modulating operating ramp 64 seconds Curve slope max. 10% for LMV36 ramp of 40 seconds (20% for 20 seconds or 40% for 10 seconds) → Between the ignition point (P0) and the low-fire point (P1), the speed change in modulating mode may be a maximum of 40%, independent of the LMV36 ramp.</p> <p>4. The setting of the VSD ramp must be about 20% faster than the ramps in the LMV36 (parameters 522, 523).</p>
	<p>Bit 4 Valency ≥ 16</p>	<p><i>Interruption of speed signal</i></p>	<p>No speed detected in spite of control.</p> <ol style="list-style-type: none"> 1. Check if the motor turns. 2. Check if the speed sensor delivers a signal (LED / check distance from the sensor disk). 3. Check wiring of the VSD.
	<p>Bit 5 Valency ≥ 32</p>	<p><i>Quick shutdown due to excessive speed deviation</i></p>	<p>Speed deviation was for about 1 s >10% outside the anticipated range.</p> <ol style="list-style-type: none"> 1. Check ramp times of the LMV36 and VSD. 2. Check wiring of the VSD.
	<p>Bit 6 Valency ≥ 64</p>	<p><i>Minimum speed fall below (phase-dependent)</i></p>	<ol style="list-style-type: none"> 1. Standby (phase 12): Check the setting for the minimum speed and maximum speed during operation (parameter 669.0 / 669.1; MAX > MIN). 2. Check the speed recording (absolute speed parameter 935, standardized speed parameter 936). 3. Prepurge phase (phase 30): Read-in speed or prepurge speed (parameter 503.1 / 506.1) below the minimum speed for prepurging (parameter 667). 4. Operating phases (phase 40...64): Read-in speed or setting of the speed curve below the minimum speed in operation (parameter 669.0).
	<p>Bit 7 Valency ≥ 128</p>	<p><i>Maximum speed exceeded (phase-dependent)</i></p>	<ol style="list-style-type: none"> 1. Standby (phase 12): Setting preignition time (parameter gas 226 / 336 or oil 266 / 366) at least 3 seconds (or \geq parameter 665) 2. Standby (phase 12): Check the setting for the minimum speed and maximum speed during operation (parameter 669.0 / 669.1; MAX > MIN). 3. Check the speed recording (absolute speed parameter 935, standardized speed parameter 936). 4. Preignition time (phase 38): Read-in speed or setting of the ignition speed (P0) above the maximum speed for ignition (parameter 668). 5. Operating phases (phase 40...64): Read-in speed or setting of the speed curve above the maximum speed in operation (parameter 669.1).
84	#	Curve slope actuators	
	<p>Bit 0 Valency 1</p>	<p>VSD: <i>Curve too steep in terms of ramp speed</i></p>	<p>Check speed differential between the curvepoints and the modulating operating ramp setting (parameter 544).</p> <ol style="list-style-type: none"> 1. Modulating operating ramp 32 seconds Curve slope max. 10% for LMV36 ramp of 20 seconds (20% for 10 seconds or 40% for 5 seconds) 2. Modulating operating ramp 48 seconds Curve slope max. 10% for LMV36 ramp of 30 seconds (20% for 15 seconds or 30% for 10 seconds)

Error code	Diagnostic code	Meaning for the LMV36	Recommended measures or causes
			<p>3. Modulating operating ramp 64 seconds Curve slope max. 10% for LMV36 ramp of 40 seconds (20% for 20 seconds or 40% for 10 seconds) → Between the ignition point (P0) and the low-fire point (P1), the speed change in modulating mode may be a maximum of 40%, independent of the LMV36 ramp.</p> <p>4. Setting of the VSD ramp must be about 20% shorter than the ramps in the LMV36 (parameters 522 and 523)</p>
	<p>Bit 1 Valency 2..3</p>	<p>Fuel actuator: Curve too steep in terms of ramp rate</p>	<p>Check position differential between the curvepoints and the modulating operating ramp setting (parameter 544).</p> <p>1. Modulating operating ramp 32 seconds The slope of the curve may be a maximum position change of 31° (15° for SQM33.6 and 9° for SQM33.7) between 2 curve points in modulating mode.</p> <p>2. Modulating operating ramp 64 seconds The slope of the curve may be a maximum position change of 62° (30° for SQM33.6 and 18° for SQM33.7) between 2 curve points in modulating mode.</p>
	<p>Bit 2 Valency 4..7</p>	<p>Air actuator: Curve too steep in terms of ramp rate</p>	<p>Check position differential between the curvepoints and the modulating operating ramp setting (parameter 544).</p> <p>1. Modulating operating ramp 32 seconds The slope of the curve may be a maximum position change of 31° (15° for SQM33.6 and 9° for SQM33.7) between 2 curve points in modulating mode.</p> <p>2. Modulating operating ramp 64 seconds The slope of the curve may be a maximum position change of 62° (30° for SQM33.6 and 18° for SQM33.7) between 2 curve points in modulating mode.</p>
85	#	Referencing error ones actuators	
	0	Referencing error of fuel actuator	<p>Referencing of fuel actuator not successful. Reference point could not be reached.</p> <p>1. Check the setting of the actuator type (parameter 613.0 or 614) 2. Check to see if actuators have been mixed up 3. Check to see if actuator is locked or overloaded</p>
	1	Referencing error of air actuator	<p>Referencing of air actuator not successful Reference point could not be reached.</p> <p>1. Check the setting of the actuator type (parameter 613.1) 2. Check to see if actuators have been mixed up 3. Check to see if actuator is locked or overloaded</p>
	<p>Bit 7 Valency ≥ 128</p>	Referencing error due to parameter change	<p>Parameterization of an actuator (e.g. the reference position) has been changed. To trigger new referencing, this error is set</p>
86	#	Error fuel actuator	
	0	Position error	Target position could not be reached within the required tolerance band.

Error code	Diagnostic code	Meaning for the LMV36	Recommended measures or causes
			→ Check to see if actuator is locked or overloaded.
	Bit 0 Valency 1	Line interruption	Line interruption detected at actuator's terminals. → Check wiring (voltage X54 across pin 5 or 6 and pin 2 >0.5 V).
	Bit 3 Valency ≥8	Curve too steep in terms of ramp rate	Check position differential between the curvepoints and the modulating operating ramp setting (parameter 544). 1. Modulating operating ramp 32 seconds The slope of the curve may be a maximum position change of 31° (15° for SQM33.6 and 9° for SQM33.7) between 2 curve points in modulating mode. 2. Modulating operating ramp 64 seconds The slope of the curve may be a maximum position change of 62° (30° for SQM33.6 and 18° for SQM33.7) between 2 curve points in modulating mode.
	Bit 4 Valency ≥ 16	Step deviation in comparison with last referencing	Actuator was overloaded or mechanically twisted. 1. Check the setting of the actuator type (parameter 613.0 or 614) 2. Check to see if the actuator is blocked somewhere along its working range. 3. Check to see if the torque is sufficient for the application.
87	#	Error air actuator	
	0	Position error	Target position could not be reached within the required tolerance band. → Check to see if actuator is locked or overloaded.
	Bit 0 Valency 1	Line interruption	Line interruption detected at actuator's terminals. → Check wiring (voltage X53 across pin 5 or 6 and pin 2 >0.5 V).
	Bit 3 Valency ≥ 8	Curve too steep in terms of ramp rate	Check position differential between the curvepoints and the modulating operating ramp setting (parameter 544). 1. Modulating operating ramp 32 seconds The slope of the curve may be a maximum position change of 31° (15° for SQM33.6 and 9° for SQM33.7) between 2 curve points in modulating mode. 2. Modulating operating ramp 64 seconds The slope of the curve may be a maximum position change of 62° (30° for SQM33.6 and 18° for SQM33.7) between 2 curve points in modulating mode.
	Bit 4 Valency ≥ 16	Sectional deviation in comparison with last referencing	Actuator was overloaded or mechanically twisted. 1. Check the setting of the actuator type (parameter 613.1) 2. Check to see if the actuator is blocked somewhere along its working range. 3. Check to see if the torque is sufficient for the application.
90	#	Internal error LMV36	
91	#	Internal error LMV36	
93	#	Error flame signal acquisition	
	3	Short-circuit of sensor	Short-circuit at QRB 1. Check wiring. 2. Flame detector possibly fault.

266/283

Error code	Diagnostic code	Meaning for the LMV36	Recommended measures or causes
95	#	Error relay supervision	
	3 Ignition transformer 4 Fuel valve V1 5 Fuel valve V2 6 Fuel valve V3	<i>External power supply NO contact</i>	Check wiring
96	#	Error relay supervision	
	3 Ignition transformer 4 Fuel valve V1 5 Fuel valve V2 6 Fuel valve V3	<i>Relay contacts have welded</i>	Test the contacts: 1. LMV36 connected to power: Fan output must be dead. 2. Disconnect power: Disconnect fan. No resistive connection between fan output and neutral conductor allowed. If one of the 2 tests fails, release the LMV36 since contact have definitively welded and safety can no longer be ensured.
97	#	Error relay supervision	
	0	<i>Safety relay contacts have welded or external power supply fed to safety relay</i>	Test the contacts: 1. LMV36 connected to power: Fan output must be dead. 2. Disconnect power: Disconnect fan. No resistive connection between fan output and neutral conductor allowed. If one of the 2 tests fails, release the LMV36 since contacts have definitively welded and safety can no longer be ensured.
98	#	Error relay supervision	
	2 Safety valve 3 Ignition transformer 4 Fuel valve V1 5 Fuel valve V2 6 Fuel valve V3	<i>Relay does not pull in</i>	Make a reset; if error occurs repeatedly, replace the LMV36
99	#	Internal error relay control	Make a reset; if error occurs repeatedly, replace the LMV36
	3	<i>Internal error relay control</i>	Make a reset. If error occurs repeatedly, replace the LMV36 Software version V03.10: If error C:99 D:3 occurs during standardization of the VSD, deactivate temporarily function <i>Alarm in case of start prevention</i> (parameter 210 = 0, when using a release contact) or <i>interrupt</i> the load controller-ON signal
100	#	Internal error relay control	Make a reset; if error occurs repeatedly, replace the LMV36
105	#	Internal error contact sampling	
	0 Pressure switch-min 1 Pressure switch-max / POC 2 Pressure switch valve proving / Fuel selection Fuel 0 / Reset 3 Air pressure switch 4 Fuel selection Fuel 1 / Load		Can be caused by capacitive loads or supply of DC voltage to the mains voltage inputs. The diagnostic code indicates the input where the problem occurred

Error code	Diagnostic code	Meaning for the LMV36	Recommended measures or causes
	<i>controller OPEN 5 Load controller ON/OFF 6 Fuel selection Fuel 0 / Load controller CLOSED 7 Safety loop / Burner flange 8 Safety valve 9 Ignition transformer 10 Fuel valve V1 11 Fuel valve V2 12 Fuel valve V3 13 Fuel selection Fuel 1 / Reset</i>		
106	#	Internal error contact request	Make a reset; if error occurs repeatedly, replace the LMV36
	<i>0 Pressure switch-min 1 Pressure switch-max / POC 2 Pressure switch valve proving / Fuel selection Fuel 0 / Reset 3 Air pressure switch 4 Fuel selection Fuel 1 / Load controller OPEN 5 Load controller ON/OFF 6 Fuel selection Fuel 0 / Load controller CLOSED 7 Safety loop / Burner flange 8 Safety valve 9 Ignition transformer 10 Fuel valve V1 11 Fuel valve V2 12 Fuel valve V3 13 Fuel selection Fuel 1 / Reset</i>		
107	#	Internal error contact request	Make a reset; if error occurs repeatedly, replace the LMV36
	<i>0 Pressure switch-min 1 Pressure switch-max / POC 2 Pressure switch valve proving / Fuel selection Fuel 0 / Reset 3 Air pressure switch 4 Fuel selection Fuel 1 / Load controller OPEN 5 Load controller ON/OFF</i>		

Error code	Diagnostic code	Meaning for the LMV36	Recommended measures or causes
	6 Fuel selection Fuel 0 / Load controller CLOSED 7 Safety loop / Burner flange 8 Safety valve 9 Ignition transformer 10 Fuel valve V1 11 Fuel valve V2 12 Fuel valve V3 13 Fuel selection Fuel 1 / Reset		
108	#	Internal error contact request	Make a reset; if error occurs repeatedly, replace the LMV36
	0 Pressure switch-min 1 Pressure switch-max / POC 2 Pressure switch valve proving / Fuel selection Fuel 0 / Reset 3 Air pressure switch 4 Fuel selection Fuel 1 / Load controller OPEN 5 Load controller ON/OFF 6 Fuel selection Fuel 0 / Load controller CLOSED 7 Safety loop / Burner flange 8 Safety valve 9 Ignition transformer 10 Fuel valve V1 11 Fuel valve V2 12 Fuel valve V3 13 Fuel selection Fuel 1 / Reset		
110	#	Internal error voltage monitor test	Make a reset; if error occurs repeatedly, replace the LMV36
111	#	Power failure	Mains voltage to low Exchange ratio diagnostics code → voltage value (120 V: 0.843 / 230 V: 1,683)
112	0	<i>Mains voltage recovery</i>	Error code for triggering a reset on power restoration (no error)
113	#	Internal error mains voltage supervision	Make a reset; if error occurs repeatedly, replace the LMV36
115	#	Internal error system counter	
116	0	<i>Designed life time exceeded (250'000 startups)</i>	Warning threshold has been reached. The LMV36 should be replaced
117	0	<i>Life time exceeded Operation no longer allowed</i>	Switch-off threshold has been reached
120	0	<i>Interrupt limitation fuel meter input</i>	Too many disturbance pulses at the fuel meters input → Improve EMC

Error code	Diagnostic code	Meaning for the LMV36	Recommended measures or causes
121	#	Internal error EEPROM access	Make a reset, repeat last parameterization / check. Restore the parameter set, if error occurs repeatedly, replace the LMV36
122	#	Internal error EEPROM access	Make a reset, repeat last parameterization / check. Restore the parameter set, if error occurs repeatedly, replace the LMV36
123	#	Internal error EEPROM access	Make a reset, repeat last parameterization / check. Restore the parameter set, if error occurs repeatedly, replace the LMV36
124	#	Internal error EEPROM access	Make a reset, repeat last parameterization / check. Restore the parameter set, if error occurs repeatedly, replace the LMV36
125	#	Internal error EEPROM read access	Make a reset, repeat last parameterization / check. If error occurs repeatedly, replace the LMV36
126	#	Internal error EEPROM write access	Make a reset, repeat last parameterization / check. If error occurs repeatedly, replace the LMV36
127	#	Internal error EEPROM access	Make a reset, repeat last parameterization / check. Restore the parameter set, if error occurs repeatedly, replace the LMV36
128	0	Internal error EEPROM access - synchronization during initialization	Make a reset; if error occurs repeatedly, replace the LMV36
129	#	Internal error EEPROM access – command synchronization	Make a reset, repeat last parameterization / check. If error occurs repeatedly, replace the LMV36
130	#	Internal error EEPROM access - timeout	Make a reset, repeat last parameterization / check. If error occurs repeatedly, replace the LMV36
131	#	Internal error EEPROM access - page on abort	Make a reset, repeat last parameterization / check. If error occurs repeatedly, replace the LMV36
132	#	Internal error EEPROM register initialization	Make a reset; if error occurs repeatedly, replace the LMV36
133	#	Internal error EEPROM access – Request synchronization	Make a reset, repeat last parameterization / check. If error occurs repeatedly, replace the LMV36
134	#	Internal error EEPROM access – Request synchronization	Make a reset, repeat last parameterization / check. If error occurs repeatedly, replace the LMV36
135	#	Internal error EEPROM access – Request synchronization	Make a reset, repeat last parameterization / check. If error occurs repeatedly, replace the LMV36
136	#	Restore	
	1	Restore started	Restore of a backup has been started (no error) New LMV36 require resetting following restore!
		for further diagnostic codes for error code 136, refer to error code 137	For measures, refer to error code 137
137	#	Internal error – backup / restore	
	157 (-99)	Restore – ok, but backup < data set of current LMV36	Restore successful, but backup data record is smaller than in the current LMV36
	239 (-17)	Backup – storage of backup in AZL2 faulty	Reset and repeat backup
	240 (-16)	Restore – no backup in AZL2	No backup stored in AZL2
	241 (-15)	Restore – abortion due to unsuitable product no. (ASN)	Backup has an unsuitable product no. (ASN) and must not be loaded on the LMV36
	242 (-14)	Backup – backup made is inconsistent	Backup is faulty and cannot be transferred back
	243 (-13)	Backup – data comparison between μ Cs faulty	Reset and repeat backup
	244 (-12)	Backup data are incompatible	Backup data are incompatible with the current software version, restore not possible
	245 (-11)	Access error to parameter Restore_Complete	Reset and repeat backup
	246 (-10)	Restore – timeout when storing in EEPROM	Reset and repeat backup

Error code	Diagnostic code	Meaning for the LMV36	Recommended measures or causes
	247 (-9)	Data received are inconsistent	Backup data record invalid, restore not possible
	248 (-8)	Restore cannot at present be made	Reset and repeat backup
	249 (-7)	Restore – abortion due to unsuitable burner identification	Backup has an unsuitable burner identification and must not be transferred to the LMV36
	250 (-6)	Backup – CRC of one page is not correct	Backup data record invalid, restore not possible
	251 (-5)	Backup – burner identification is not defined	Define burner identification and repeat backup
	252 (-4)	After restore, pages still on ABORT	Reset and repeat backup
	253 (-3)	Restore cannot at present be made	Reset and repeat backup
	254 (-2)	Abortion due to transmission error	Reset and repeat backup
	255 (-1)	Abortion due to timeout during backup / restore	Make a reset, check the connections and repeat backup / restore In case of repeated backup timeout, the AZL2 does not yet support backup functionality
146	#	Timeout building automation interface	Refer to Modbus User Documentation (A7541)
	1	Modbus timeout	
	2	eBus timeout	
150	#	TÜV test	
	1 (-1)	Invalid phase	TÜV test may only be started in phase 60 (operation)
	2 (-2)	TÜV test default output too low	TÜV test default output must not be smaller than the lower output limit
	3 (-3)	TÜV test default output too high	TÜV test default output must not be greater than the upper output limit
	4 (-4)	Manual interruption	No error: Manual abortion of TÜV test by user
	5 (-5)	TÜV test timeout	No loss of flame after shutdown of fuel valves 1. Check to see if there is extraneous light 2. Check wiring to see if there is a short-circuit 3. Check to see if valve is leaking
154	#	Trim function: Invalid analog value	1. Check wiring of analog trim specification to see if there is an open-circuit / loose contact 2. Check the process date of the read-in trim specification (parameter 916; 4 mA = -15% / 12 mA = 0% / 20 mA = 15%)
	1	Start prevention	
	2	Warning message (trim function temporarily deactivated)	
155	#	Trim function: Invalid curve setting VSD / PWM fan	The curve setting of the VSD / PWM fan must include a reserve for the set trim range. ((Minimum value curve + negative trim range) ≤ curve point ≤ (maximum value curve - positive trim range))
	1..9	Minimum value VSD curve fall below	The curvepoint of the VSD curve is below the permissible minimum value (diagnostic code = curvepoint number; e.g. 1 = P1)
	21..29	Maximum value VSD curve exceeded	The curvepoint of the VSD curve is above the permissible maximum value (diagnostic code = curvepoint number; e.g. 21 = P1)
	41..49	Fuel 1: Minimum value VSD curve fall below	Fuel 1: The curvepoint of the VSD curve is below the permissible minimum value (diagnostic code = curvepoint number; e.g. 41 = P1)
	61..69	Fuel 1: Maximum value VSD curve exceeded	Fuel 1: The curvepoint of the VSD curve is above the permissible maximum value

Error code	Diagnostic code	Meaning for the LMV36	Recommended measures or causes
			(diagnostic code = curvepoint number; e.g. 61 = P1)
156	#	Trim function: Maximum time for range limit exceeded	 Warning message! Trim function is in limitation for too long (parameter 535; 916 < 531 or 916 > 532). This can be an indication that the trim function or the VSD curve is set incorrectly.
	0	Trim function at lower limit	
	1	Trim function at upper limit	
	10	Fuel 1: Trim function at lower limit	
	11	Fuel 1: Trim function at upper limit	
157	#	Trim function: Analog input test	Test value of the analog input is outside the tolerance range
	0	Analog value standby	1. Check whether a current setting of 12 mA is present in standby. 2. Check parameter 916 (permissible value range -1...+1%).
	1	Analog value prepurging	1. Check whether a current setting of 4 mA is present in prepurging. 2. Check parameter 916 (permissible value range -16...-14%).
165	#	Internal error	
166	0	Internal error watchdog reset	
167	#	Manual locking	LMV36 has been manually locked (no error)
	1	Manual locking by contact	
	2	Manual locking by AZL2	
	3	Manual locking by PC software ACS410	
	8	Manual locking by the AZL2 Timeout / communication breakdown	During a curve adjustment via the AZL2, the timeout for menu operation has elapsed (setting via parameter 127), or communication between the LMV36 and the AZL2 has broken down
	9	Manual locking by the PC software ACS410 Communication breakdown	During a curve adjustment via the ACS410, communication between the LMV36 and the ACS410 was interrupted for more than 30 seconds
	33	Manual locking by the PC software ACS410 Test of lockout	Via PC software ACS410, a reset attempt was made with an error-free LMV36.
168	#	Internal error management	Make a reset; if error occurs repeatedly, replace the LMV36
169	#	Internal error management	Make a reset; if error occurs repeatedly, replace the LMV36
170	#	Internal error management	Make a reset; if error occurs repeatedly, replace the LMV36
171	#	Internal error management	Make a reset; if error occurs repeatedly, replace the LMV36
200 OFF	#	LMV36 error-free	No error
201 OFF UPr0 or OFF UPr1	#	Prevention of startup	Start prevention due to unparameterized LMV36 Go to error history, entry 702, for initial cause of the error with shutdown in connection with the first curve settings
	Bit 0 Valency 1	No operating mode selected	
	Bit 1 Valency 2..3	No fuel train defined	

272/283

Error code	Diagnostic code	Meaning for the LMV36	Recommended measures or causes
	Bit 2 Valency 4..7	No curves defined	
	Bit 3 Valency 8..15	Standardized speed undefined	Carry out speed standardization. If no speed signal is present in pneumatic operation, the parameters 667, 668, 669.0 / 669.1 must be set to <i>invalid</i> to switch off the start prevention.
	Bit 4 Valency 16..31	Backup / restore was not possible	
202	#	Internal error operating mode selection	Redefine the operating mode (parameter 201)
203	#	Internal error	Redefine the operating mode (parameter 201). Make a reset; if error occurs repeatedly, replace the LMV36
204	Phase number	Program stop	Program stop is active (no error)
205	#	Internal error	Make a reset; if error occurs repeatedly, replace the LMV36
206	0	Inadmissible combination of units (LMV36 – AZL2)	
207	#	Version compatibility LMV36 – AZL2	
	0	LMV36 version too old	
	1	AZL2 version too old	
208	#	Internal error	Make a reset; if error occurs repeatedly, replace the LMV36
209	#	Internal error	Make a reset; if error occurs repeatedly, replace the LMV36
210	0	Selected operation mode is not released for the LMV36	Select a released operation mode for the LMV36
240	#	Internal error	Make a reset; if error occurs repeatedly, replace the LMV36
242	#	Invalid parameterization	
	0	Invalid setting parameter 277	Set parameter 277 to a valid value
	1	Invalid setting parameter 377	Set parameter 377 to a valid value
245	#	Internal error	Make a reset; if error occurs repeatedly, replace the LMV36
250	#	Internal error	Make a reset; if error occurs repeatedly, replace the LMV36

31 Revision history of LMV36

Software changes

Software version V03.00

- Optimization: Maximum time of safety phase reduced from 28 to 27 seconds
- Optimization: Correction of error diagnostics C:61 D:0 or 1 (Fuel Chg)
- Optimization: No error *Fuel Err* when pressing the reset button for a short moment after a reset / power-on
- Parameter 376: Deactivation of oil pressure switch-min for fuel 1

Software version V03.10

- Optimization: If power supply fails during the restore process, the data set can be repaired by starting a new restore process (since the backup / restore option is not yet available with V03.00 because there is no suitable AZL2, this effect cannot occur)
- Optimization: If the analog input is interrupted, error C:60 (no valid load controller source) is canceled or reset when *Default output low-fire* is parameterized (only with LMV36)
- Optimization: When making a reset via the AZL2, an *incomplete* reset occurred in very rare cases (display showed *RESEt*, but reset was not triggered)
- Optimization: The time of 0.2 seconds ascertained by the loss-of-flame test was too long
- Optimization: No continuous purging with the LMV36 (in prepurge / ignition position) during the gas shortage waiting time when using a VSD and valve proving via gas pressure switch-min
- Optimization: With fuel changeover, error codes C:85 / C:86 do not occur any more
- Optimization: Reduced detection of undervoltage when fan motor is started in phase 22 (when a single-phase motor and the LMV36 120 V were powered via the same phase, undervoltage detection could occur on startup; in that case, the LMV36 was not operated as specified)
- Optimization: Better overview through text changes of groups 200 = PAr0, 300 = PAr1 and 600 = ACtr on the parameter menu (initially PArA), and hiding of unused parameters after selection of fuel train / operating mode (no display of oil parameters in gas fuel train)
- Optimization: Control of the fan output during standardization (standby) for using a release contact via an external relay at the fan's output
- Optimization: Curve setting invalid (OFF UPr) after new / further standardization
- Optimization: To shorten the startup time, there is no referencing when postpurging is aborted via load controller ON (direct start)
- Automatic return travel of the SQN1 at the lower internal stop
- Parameter on Siemens level
Longer ignition off time during the first safety time (increased from 0.4 to 0.6 seconds) to prevent wrong error diagnostics in connection with QRA2 (C:7 in place of C:2)
- Parameter at the Siemens level:
Readjustment of threshold for detection of interruption based on operation with AGM60 and 2 fuel actuators
- Creation of new parameter sets for the burner output test based on V01.05 (otherwise, due to a restore process with old data sets during the burner output test, parameter changes at the safety limit thermostat level might be overwritten again)

Software version V03.30

- Extension: Display of intensity of flame when setting the curves
- Optimization: Display and diagnostics of changing start preventions
- Optimization: No unplausible relay setpoint (error C:99 D:3) when starting standardization, alarm in case of start prevention and load controller ON signal
- Optimization: No VSD standardization with pneumatic air-fuel ratio control
- Optimization: Referencing in connection with direction of rotation *Right* and home position 90°
- Extension: Separate pressure switch valve proving via X5-02 (pressure switch-max / POC)

Software version V03.40

- Extension: Supports SQM33.6 or SQM33.7
- Extension: Postpurging in the lockout position
- Optimization: Shutdown of VSD control when burner flange / safety loop is open
- Optimization: Minimum setting for prepurge time: 5 seconds
- Optimization: Standstill supervision of the VSD can be switched off in standby mode
- Extension: *No flame at the end of safety time* repetition counter, adjustable *air pressure failure* (OEM), heavy oil direct start (SO)
- Extension: Air pressure supervision in operation with pneumatic ratio control can be switched off (OEM)
- Extension: VSD ramp time increased to 40 seconds
- Extension: Modbus data points
 - 127 = Fuel 0 operating mode (parameter 201)
 - 128 = Fuel 1 operating mode (parameter 301)

Software version V03.70

- Optimization: No locking with C:75 via asynchronous load controller source
- Extension: Support of PWM fans and symmetrical feedback
- Extension: Increase in the maximum speed to 14000 rpm
- Extension: Additional monitoring of the minimum prepurge speed, maximum ignition speed and minimum speed / maximum speed during operation
- Extension: Increased flexibility when setting the curve (gradient VSD curve)
- Extension: Operating modes for G / Gp2 with mechanical ratio control (air actuator only)
- Extension: Trim function for e.g. O2 or temperature
- Extension: Separate phase for running the fan to ignition speed, postpurge speed or standby speed, as well as increased speed tolerance outside operation
- Extension: Speed-dependent air pressure switch
- Extension: Increase in the flame sensitivity
- Extension: Gas pressure switch-min positioned after the fuel valves (CSA 149.3)
- Extension: Immediate lockout in the event of inadequate air supply (UL 795 / EN 676)
- Optimization: No repetition during successive error messages
- Extension: At the end of the speed standardization, the speed must be <10%
- Extension: Modbus data points
 - 140 = fuel 0 operating mode (parameter 201)
 - 141 = fuel 1 operating mode (parameter 301)
 - 142 = meter for function *Revert to Pilot*
 - 144 = lower range limit trim function
 - 145 = upper range limit trim function
 - 146 = lower range limit trim function fuel 1
 - 147 = upper range limit trim function fuel 1
 - 148 = input value analog input trim function
 - 149 = current trim impact
 - 150 = absolute speed
 - 151 = standardized mains voltage (conversion required)

Index

A	
ACS410	167
Display / diagnostics	42
Actuators	124
Angles definition	124
Direction of rotation	129
Error detection band	132
Forced travel	132
Function principle	124
Line interruption detection	132
Mixup protection	133
Proposal - implementation	133
Position	130
Referencing	125
Reference run	127
AGM60	99
Cable lengths	40
Connecting cable to LMV36	100
Continuous operation	27
Cross-sectional areas	40
Digital inputs	
X5-01	54
Dimensions	42
Electrical connections	16
Electrical connections of	
actuators	40
Environmental conditions	40
Extra fuel selector	27
Fuel actuators - electrical	
connection	26
Fuel changeover	27
Function description	26
Installation notes	15
Technical data	38
Terminal output inputs	39
Terminal output outputs	39
Type summary	28
With LMV36 and 1 fuel actuator	99
With LMV36 and 2 fuel actuators	99
Aquisition of speed	
Fan forced travel	140
Speed extended supervision ..	142
AZL2	
Backup	175
Burner identification	188
Burner identification entry	197
Buttons description	171
Display / diagnostics	42
Display brightness	172
Display description	171
Display of info level	186
Error display	183
Error history	192
Error safety shutdown	184
Fault status messages	183
Faults number	192
Flame intensity	192
Fuel-air ratio curves	212, 225
Flame intensity	234
G mod	215, 217
G mod pneu	216, 223
Gp1 mod	215, 217
Gp1 mod pneu	216, 223
Gp2 mod	215, 217, 223
Gp2 mod pneu	216
Initial commissioning	212
Interpolation	224
Lo 2-stage	228, 229, 233
Lo 3-stage	228, 229, 233
Lo mod	215, 217
General information	184
Heating engineer's password	
change	199
Identification date	187
Identification number	187
Index parameter, direct display	
.....	207
Info / service mode	183
Info level	186
Info level end	190
Info value display	187
Level assignment	185
LMV36 operation	180
Manual control	174
Manual lockout	173
Meaning of symbol	172
Menu operation timeout	175
Menu-driven operation	185
No parameter index, no direct	
display	205
No parameters index / direct	
display	203
Normal display	180
OEM's password change	200
Operating	171
Operating position display	182
Parameter index, no direct	
display	209
Parameter level	194
Parameter level structure	202
Parameter level use	201
Password entry	195
Phase display list	181
Program phase display - running	
time	180

Program phases display.....	180	Multistage operation.....	120
Reset.....	183	Curve definition.....	120
Restore.....	175	Modulation range.....	122
Safety loop.....	184	Operating position.....	121
Safety notes.....	170	Output adjustment.....	121
Service level.....	191	Traveling speed.....	120
Service level end.....	193	Operating position.....	117
Service value display.....	192	Operating position end.....	122
Shutdown display.....	180	Outside - operating position...	112
Special functions.....	173	Postpurging.....	113
Standby mode display.....	180	Prepurging.....	113
Startup display.....	180	Running position.....	117
Startup number resettable.....	189	Setting notes.....	123
Startup number total.....	190	Traveling speed.....	112, 116
Startup prevention.....	184	Error history.....	168
B		Error classes.....	168
Burner Identification.....	164	Error history makeup.....	169
C		F	
Connection diagram.....	162	Fan control.....	134
D		Connection terminals.....	157
Digital inputs		PWM fan.....	157
Fuel selection.....	60	VSD.....	157
Setting time - pressure switch .	55	Control.....	147
X3-02.....	50	EMC.....	148
X3-03 pin 1 / 2.....	49	Function principle.....	134
X3-04 pin 1 / 2.....	48	Parameter settings.....	143
X5-01.....	52	PWM fan special conditions ...	148
X5-02.....	56	Ramp time.....	137
X5-03 pin 1.....	49	Safe separation.....	136
X8-04 pin 1.....	60	Speed acquisition.....	138
X9-04.....	51, 54	Hall generator.....	139
Digital outputs		Proximity switch.....	138
X3-05 pin 1.....	61	Speed control.....	140
X3-05 pin 2.....	61	Speed standardization.....	144
X3-05 pin 3.....	61	Speed supervision.....	141
X4-02.....	62	Trim function.....	151
X6-03.....	65	External tests.....	155
X7-01.....	63	VSD / PWM fan activation.....	134
X7-02.....	63	X64 pin 3.....	136
X8-02.....	63	X74 pin 3.....	135
X8-04 pin 2.....	65	Flame detector	
Dimensions.....	41	Flame detection sensitivity.....	47
Display / diagnostics.....	42	Flame detectors	
E		Extraneous light.....	46
Electronic fuel-air ratio control ...	112	Flame intensity.....	46
Curves definition.....	115	Loss of flame.....	45
General.....	112	No flame at the end of safety time	
Home position.....	112	Supervision.....	46
Ignition.....	113	Fuel meter input.....	160
Max. curve slope.....	116	Configuration.....	160
Min. / Max. output.....	119	Pulses per volume unit.....	160
Modulating operation.....	114	Reading.....	160
Modulation range.....	118	Resetting.....	160
		Types.....	160
		Fuel throughput.....	161

Configuration	161	M	
Reading out	161	Make of structure	24
Fuel selector		O	
Type summary	28	Operating mode selection	101
Function description	24	Deleting curves	104
General information.....	25	P	
North America.....	24	Program sequence	
I		Alarm	73
Internal diagram	162	Continuous fan.....	79
Ionization probe		Forced intermittent operation ..	78
Technical data.....	33	Gas shortage program.....	77
L		Low-fire shutdown	79
Lifecycle function	170	Manual lockout.....	72
LMV36	43	Phase 00	71
Cable lengths	31	Phase 02	71
Connections of actuators	31	Postpurging.....	81
Cross-sectional areas	31	Program stop.....	78
Digital inputs	48	Repetition counter	74
Digital outputs.....	61	Reset	72
Dimensions	41	Special functions	72
Electrical connections	15	Start without prepurging	76
Error code list	257	Startup.....	73
Flame detectors	44	Time parameters	66
Fuel trains	82	TÜV test.....	80
Function description	24	Valve proving	68
Inputs / outputs.....	43	X5-01.....	70
Parameter list.....	235	X9-04.....	69
Program sequence	66	PWM fan	
Sequence diagrams.....	90	Acquisition of speed.....	150
Technical data.....	29	Characteristics	149
Terminal loading inputs	29	Q	
Terminal loading outputs.....	30	QRA	
Type summary	28	Technical data	35
X74 pin 3	31	QRB	
Load controller connection.....	105	Technical data.....	36
Load controller sources	110	QRB4	
Manual output.....	107	Technical data.....	37
Output - curve settings	107	S	
Threshold - modulating operation		Safety notes	10
.....	108	AGM60	
Threshold - multistage operation		Electrical connections	15
.....	109	Mounting notes.....	13
X5-03 pin 1	105	Commissioning notes.....	19
X64 pin 1	108	Disposal notes.....	23
X64 pin 2	108	Flame detectors	
X92	105	Electrical connection	18
Load controller sources		Installation notes.....	14
Emergency operation	111	Life cycle.....	23
Load output	158	LMV36	
2-stage operation.....	159	Electrical connections	15
3-stage operation.....	159	Mounting notes.....	12
Modulating operation	159	Mounting notes	12
Safe separation.....	158	Service notes	23

Setting notes.....	21	LoGp mod.....	95
Standards and certificates	22	Superposed system connection..	164
Warning notes	10	Building automation functions	
X56		164
Connection BC interface via		General information.....	164
integrated RJ jack.....	17	Modbus	166
Sequence diagrams		T	
G.....	91	Technical data	29
G mod	91	AGV50 from AZL2 to BC interface	
G mod pneu	91	32
Gp1	92	Environmental conditions.....	32
Gp1 mod.....	92	Flame detectors	33
Gp1 mod pneu	92	Trim function	
Gp2	93	Internal check optional.....	153
Gp2 mod.....	93	Settings / mode of operation ..	152
Gp2 mod pneu	93	Type summary	28
Legend.....	96	X	
Lo	94	X53 / X54	124
Lo 2-stage	94	X74 pin 3	158
Lo 3-stage	94	X75 pin 1	160
Lo mod	94	X75 pin 2	160
LoGp.....	95		
LoGp 2 stage.....	95		

31.1 List of figures

Figure 1: LMV36 note on mounting.....	12
Figure 2: AGM60 note for mounting.....	13
Figure 3: AGM60: Mounting method.....	13
Figure 4: LMV36 electrical connection	15
Figure 5: AGM60 electrical connection	16
Figure 6: AGM60 lateral connecting area	16
Figure 7: Connection interface OCI410 on the BC interface.....	17
Figure 8: Makeup of structure	24
Figure 9: Connections of fuel actuators	26
Figure 10: LMV36 with AGM60: Fuel changeover	27
Figure 11: AGM60 extra fuel selector	27
Figure 12: Ionization input at AC 120 V	34
Figure 13: Measuring circuit for ionization probe	34
Figure 14: Measuring circuit QRA.....	35
Figure 15: QRB1/QRB3 input at AC 230 V	36
Figure 16: Dimensions of the LMV36.....	41
Figure 17: Dimensions of the AGM60.....	42
Figure 18: Flame signal input X10-05	43
Figure 19: Flame signal input X10-06	43
Figure 20: Safety loop (optional pressure switch-max) X3-04	48
Figure 21: Burner flange X3-03.....	49
Figure 22: Inputs for external load controller ON / OFF X5-03	49
Figure 23: Air pressure switch X3-02.....	50
Figure 24: LMV36: Pressure switch valve proving gas X9-04	51
Figure 25: LMV36 with AGM60: Pressure switch valve proving gas X9-04	51
Figure 26: Gas pressure switch-min X5-01.....	52
Figure 27: LMV36: Oil pressure switch-valve proving X9-04	54
Figure 28: LMV36 with AGM60: Oil pressure switch-valve proving X5-01	54
Figure 29: LMV36: Gas / oil Pressure switch-max or POC X5-02	56
Figure 30: LMV36 with AGM60: Gas / oil pressure switch-max or POC X5-02	56
Figure 31: Additional speed-dependent air pressure switch	59
Figure 32: LMV36 with AGM60: Fuel selection.....	60
Figure 33: Reset X8-04.....	60
Figure 34: Output alarm X3-05	61
Figure 35: Fan motor contactor X3-05	61

Figure 36: Continuous fan operation X3-05.....	61
Figure 37: Output ignition X4-02.....	62
Figure 38: LMV36: Output fuel valve V1 X8-02	63
Figure 39: LMV36 with AGM60: Output fuel valve V1 X8-02	63
Figure 40: LMV36: Output fuel valve V2 X7-01	64
Figure 41: LMV36 with AGM60: Output fuel valve V2 X7-01	64
Figure 42: LMV36: Output fuel valve V3 / pilot valve X7-02	64
Figure 43: LMV36: Output safety valve / magnetic clutch X6-03.....	65
Figure 44: LMV36 with AGM60: Output safety valve / magnetic clutch X6-03	65
Figure 45: Output for indication of operation X8-04.....	65
Figure 46: Valve proving with separate	69
Figure 47: Valve proving via gas pressure switch-min	70
Figure 48: Without manual lockout	72
Figure 49: With manual lockout	72
Figure 50: Message in the case of program stop	78
Figure 51: Continuous fan	79
Figure 52: Application example of postpurging in the lockout position with fan but without VSD.....	81
Figure 53: Application example of postpurging in the lockout position with fan and VSD release contact	81
Figure 54: Gas direct ignition.....	82
Figure 55: Gas pilot ignition 1	82
Figure 56: Gas pilot ignition 2	82
Figure 57: Gas – fuel valve control	83
Figure 58: Light oil direct ignition, multistage	84
Figure 59: Light oil direct ignition, 2-stage	84
Figure 60: Light oil direct ignition, 3-stage	84
Figure 61: Light oil direct ignition, modulating	85
Figure 62: Light oil ignition, modulating	85
Figure 63: Light oil direct ignition - fuel valve control.....	85
Figure 64: Dual fuel burner gas / light oil with gas pilot ignition.....	86
Figure 65: Light oil – gas pilot ignition – fuel valve control	86
Figure 66: Light oil – direct ignition, modulating, without shutdown facility for adjustable head	87
Figure 67: Light oil – direct ignition, modulating, with shutdown facility for adjustable head	87
Figure 68: Light oil –direct ignition – fuel valve control.....	87
Figure 69: Dual fuel burner gas / light oil with gas pilot ignition, with 2 fuel valves	88
Figure 70: Light oil with gas pilot ignition – fuel valve control.....	88

Figure 71: Light oil with gas pilot ignition	89
Figure 72: Light oil with gas pilot ignition – fuel valve control	89
Figure 73: Light oil with gas pilot ignition	90
Figure 74: Light oil with gas pilot ignition – fuel valve control	90
Figure 75: Program for gas direct ignition (G), (G mod), (G mod pneu)	91
Figure 76: Program for gas pilot ignition (Gp1), (Gp1 mod), (Gp1 mod pneu)	92
Figure 77: Program for gas pilot ignition (Gp2), (Gp2 mod), (Gp2 mod pneu)	93
Figure 78: Program for light oil direct ignition (Lo), (Lo mod), (Lo 2-stage), (Lo 3-stage)	94
Figure 79: Program light pilot ignition «LoGp» «LoGp mod» «LoGp 2 stage»	95
Figure 80: LMV36 with AGM60 and one fuel actuator	99
Figure 81: LMV36 with AGM60 and two fuel actuator	99
Figure 82: External load controller via analog input X64 pin 1 / X64 pin 2	108
Figure 83: Definition of curves	115
Figure 84: Restriction of modulation range	118
Figure 85: Adjustment of output	121
Figure 86: Fuel actuator (X54)	124
Figure 87: Air actuator (X53)	124
Figure 88: Angle definitions with SQM33	128
Figure 89: Direction of rotation (example SQM3)	129
Figure 90: Function principle of fan control	134
Figure 91: Connection of VSD to the LMV36	135
Figure 92: Power output	136
Figure 93: Sensor disk	138
Figure 94: Speed sensor	139
Figure 95: Extended speed supervision	142
Figure 96: Setting range trim limits	152
Figure 97: Trim supervision with PLC	155
Figure 98: VSD connection X74	157
Figure 99: PWM fan X74	157
Figure 100: PWM fan X64	157
Figure 101: Power output	158
Figure 102: Fuel meter input X75	160
Figure 103: Inputs and outputs	162
Figure 104: Switching between 2 ration control curves	163
Figure 105: Connection via COM X92 to superposed systems	164
Figure 106: Communication with display / BC interface (RJ11 jack) (X56)	167
Figure 107: Display input / BC interface (RJ11 jack) X56	167

Figure 108: Description of unit/display and buttons.....	171
Figure 109: Meaning of display	172
Figure 110: Assignment of levels	185
Figure 111: Info level.....	186
Figure 112: Service level.....	191
Figure 113: Structure of parameter levels	202
Figure 114: Setting the curvepoints	220
Figure 115: Changing several curvepoints	227