

HYDAC

INTERNATIONAL

Cooling Product Catalogue



HYDAC Cooling – with Global Reach



Coolers and heat exchangers for industry ...



... and mobile applications.



HYDAC Heat Exchangers and Cooling Systems – a Cool Solution for Every Application

Hydraulic and lubrication systems play a major role in almost all stationary and mobile machines. The fluids used transmit power, provide lubrication, channel away heat and protect from corrosion.

The quality of the fluid is the fingerprint of the whole system. The temperature control and purity of the fluid, for example, are crucial factors for the state of the entire control equipment in mobile-hydraulic applications.

In all hydraulic systems, energy is converted and transported.

This involves some energy being lost, in the form of heat. The task of the cooling systems is to dissipate the heat.

Efficient cooling systems can help to lengthen the service life of the operating fluids and filters used and reduce life cycle costs.

HYDAC Cooling's product range includes coolers, heat exchangers and cooling systems for almost all industries and applications.

We can cool not only hydraulic systems but also electric drives and motors, generators, inverters and transformers.

Our cooling systems enable gearboxes to be cooled and lubricated and mobile working equipment and vehicles to keep going for longer.

Whether your cooling involves air or water, return flow or bypass flow, standard or customized solutions – we are always happy to help.

Close to Customers Worldwide

With over 7,500 employees worldwide, HYDAC is one of the leading suppliers of fluid technology, process technology and hydraulic and electronic equipment.

With 50 overseas companies and over 500 sales and service partners, HYDAC is your skilled and reliable partner – worldwide.

HYDAC Cooling operates the following production sites:

- HYDAC Cooling GmbH, Sulzbach/Germany
- HYDAC H.I.B. Systemtechnik GmbH, Augsburg/Germany
- HYDAC AG, Mezzovico/Switzerland
- HYDAC IBS Technology S.p.a., Tradate/Italy
- HYDAC Technology Corporation, Chicago (IL) and Denver (NC)/USA
- HYDAC Tecnologia LTDA, São Bernardo do Campo/Brazil
- HYDAC Pvt. Ltd., Coimbatore/India
- HYDAC Technology Ltd., Shanghai/China
- HYDAC Pty. Ltd., Melbourne/Australia

	Page
HYDAC Cooling – with Global Reach	2
Your Partner for Expertise in Sustainable Solutions	4
Research and Development for Intelligent Solutions	5
Industries and Applications	
... in Stationary Equipment	6
... in Mobile Technology	7
... for Machine Tools	8
... in Wind Energy	9
Overview of Cooling Products	10
Air Coolers, Industry/Mobile	17
● AC-LN 1-7, ACA-LN 2-7, ACAF-LN 2-7	29
● AC-LN 8-14, ACA-LN 8-11, ACAF-LN 8-11	43
● AC-LN 8-14 MI	55
● OSCA / OSCAF 0-3	65
● OK-ELC 0-7	73
● AC-MS	83
● AC-LN / ACA-LN / ACAF-LN / AC-LNH ATEX	89
● AC-LN / ACA-LN / ACAF-LN 2-14 Corrosion Protection Levels (CPL)	91
● OK-ELH 2-7	93
● AC-LNH 8-14	103
● OK-ELD 0-6	115
● CMS	125
● Accessories	127
Plate Heat Exchangers	145
● HYDAC HEX Sxxx	149
● Hxxx-LIQUID	155
Feed Pumps	
● FZP, MFZP	161
● VP, VPB, VPBM	171
Pump-Transfer Cooler Filtration Units	
● UF 2-3, UKF 1-3	181
● UKF for Gearboxes	199
Fluid/Air Cooling Systems	203
● FLKS	207
Fluid Cooling Systems	
● FWKS	281
● RFCS	287
● HCC	295
Customized Cooling Solutions	
● Gearbox Cooling Systems	301
● Water Glycol Circuits	305
Buyer's Guide	309

Note

The information in this brochure relates to the operating conditions and applications described.

For applications and operating conditions not described, please contact the relevant technical department.

Subject to technical modifications.

Your Partner for Expertise in Sustainable Solutions



Conserving Resources and Protecting the Environment with Intelligent Solutions

As resources are limited, sustainability is a global challenge. Energy efficiency is an important step towards greater sustainability in stationary and mobile technology. HYDAC has spent years developing intelligent and energy-efficient products and solutions to help you to make your operations sustainable. Alongside cooling systems that are particularly economical in their use of available resources, we offer systems and solutions that make use of the heat that is often inevitably lost in industrial processes, for example by returning it to the process water or the heating circuit. This allows you to save natural and financial resources in the long term.

Using energy efficiently is only one way to increase sustainability. Other important methods are increasing service life and optimizing new and existing plants in hydraulics, fluid technology and electronics.

The main features of energy-efficient components and systems are as follows:

- Lightweight and compact design
- Optimized drive power
- Speed-controlled fans
- Control based on ambient conditions
- Low noise level
- Energy-efficient refrigeration technology

Energy-efficient model series can be recognized by their green "HYDAC ENERGY SAVING" seal.

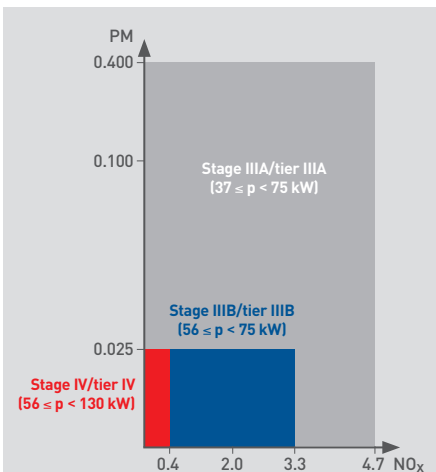

Up to 2010 > Level IIIA/tier III
NO_x reduction 30 – 40 %
From 2011 > Level IIIB/tier IV interim
Particle reduction >90 %
From 2014 > Level IV/tier IV final
NO_x reduction >90 %



Hydraulic oil cooler for concrete pump with integrated filter

HYDAC Cooling Modules for Engines of all Emission Levels

As a result of the increased requirements concerning energy efficiency and noise development in mobile machines, cooling systems for these vehicles have to be designed to the limits of physical possibility.

By combining multiple cooling circuits, integrating functions (such as tank and filter functions) and using electrical and hydraulic fan controls, HYDAC mobile coolers are well-equipped to deal with all requirements.

The advantages of energy-efficient engineering include:

- Noise reduction
- Reduced fuel consumption
- Reduction in emissions
- Saving space thanks to compact designs

Research and Development for Intelligent Solutions



Development Resources and Software Development

HYDAC provides support throughout, from risk analysis to certified machine function. HYDAC provides support and advice to the customer, as required, through the entire product development cycle – from design and simulation, right through to the application software, commissioning and series production.

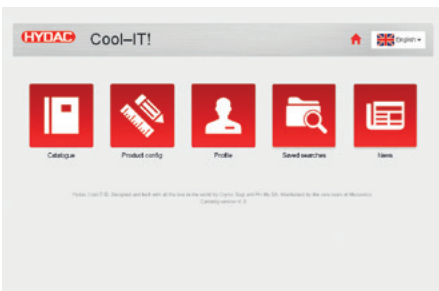

Design Programs and the KULI Simulation Software

To help you to find the perfect cooling solution for your particular requirements, you can make use of the design software “Cool-IT” or the design program for soldered plate heat exchangers. This is important because only correctly configured components can provide an efficient cooling that saves energy, reduces strain to your budget by minimizing “Life Cycle Costs” and extends the operational reliability of your systems.

We can gladly assign you a specific HYDAC contact to help you with optimizing your design to suit your needs.

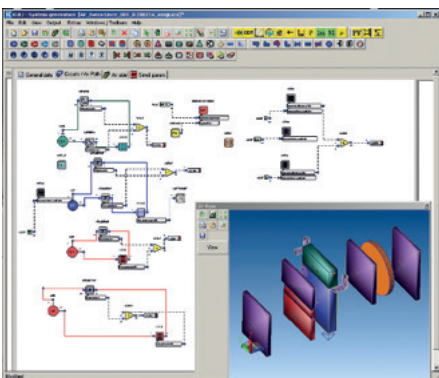

With the KULI software it is possible to scrutinize the thermal economy of a machine in its entirety. But KULI can also be used to design individual coolers or heat exchangers. Reliable design of coolers or cooling systems is made possible by the simulation of the various heat balances of the individual components based on the measurement data of a model heat exchanger in the wind tunnel. At HYDAC, a team of development engineers work with the above-mentioned simulation methods to optimize existing components and systems and to indicate new solution approaches, including customer-specific ones.

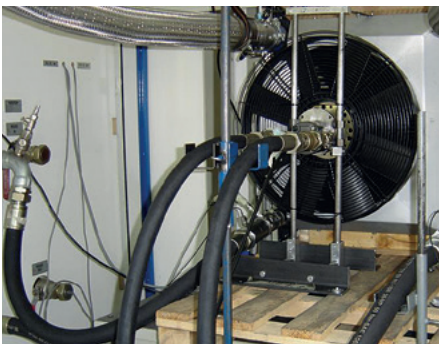

Test benches for cooling capacity measurements

We Check our Development Findings – to Protect your Operational Reliability

We make it our challenge to offer you the best and most economical solution.

Thanks to numerous test benches that test functional and operational reliability by means of the static and dynamic responses of components, assemblies and systems, we can guarantee powerful, optimized and energy-efficient cooling solutions for all kinds of requirements.



Test bench for pressure pulsation



Thermal shock test bench



Wind tunnel

Industries and Applications in Stationary Equipment

Industries

- Power plant technology
- Oil and gas industry
- Plastic injection moulding machines
- Forming machines
- Iron and steel
- Transformers
- Mining and tunnelling
- Paper industry
- Shipping
- Test benches
- Solar power
- Hydroelectric power

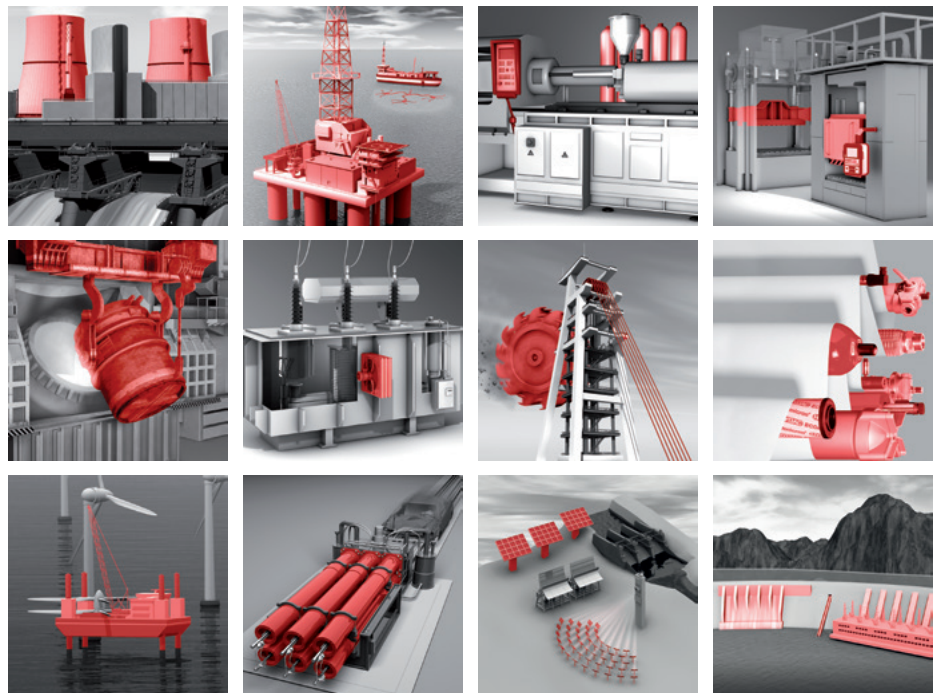

Applications

- Hydraulic cooling
- Gearbox cooling and lubrication
- Bearing cooling and lubrication
- Generator, inverter, transformer cooling
- Engine cooling
- Cooling electric drives
- Control cabinet cooling

with air coolers, plate heat exchangers or cooling systems

Industries and Applications in Mobile Technology

Industries

Construction machinery

- Wheel loaders
- Excavators
- Road construction machinery
- Telescopic cranes
- Telescopic loaders
- Materials handling

Municipal machines

Agricultural and forestry machines

- Tractors
- Field sprayers
- Combine harvesters
- Harvesters



Applications

Cooling of

- Hydraulic oil
- Gear oil
- Refrigerant
- Charge air
- Fuel

with air coolers or plate heat exchangers

Repumping of hydraulic oil or diesel fuel with filling pumps

Industries and Applications for Machine Tools

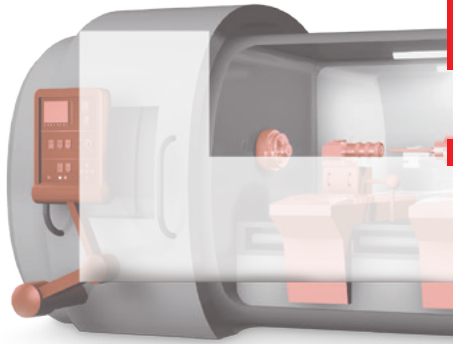

Applications

- Cooling of AC main drives
- Cooling of motor spindles in processing machines
- Fluid-cooled drives
- Inverter cooling
- Gearbox cooling
- Cooling lubricant cooling



FLKS with closed-loop speed control

- Fixed value control or control based on differential temperature (of surroundings or machine bed)
- Reduced noise and energy-efficient



FWKS with electronic control

- Fixed value control or control based on differential temperature (of surroundings or machine bed)
- Cooling below ambient temperature also possible
- Energy-efficient



Compressor cooling systems with mixer valve technology

- Stable cooling to ambient temperature or below
- Accuracy up to ± 0.2 K

see brochures no. 5.818 (FLKS)
5.618 (FLKS)
5.824 (RFCS)

Industries and Applications in Wind Energy

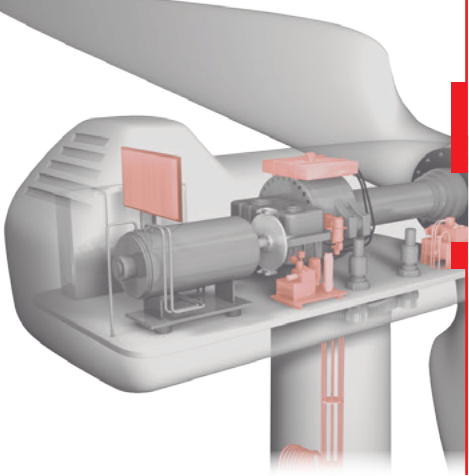

Applications

- System consultation and design (also for extreme climate zones CCV and HCV)
- Cooling and lubrication of gearboxes
- Generator cooling
- Combined cooling of the gearbox and generator
- Inverter cooling



Gearbox cooling and lubrication

- Motor pump group with filter
- Cooling with air cooler or plate heat exchanger

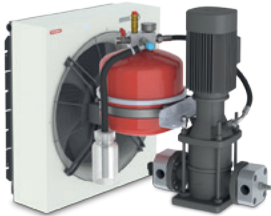

Generator cooling

- Water glycol circuit with air cooler or passive cooling element

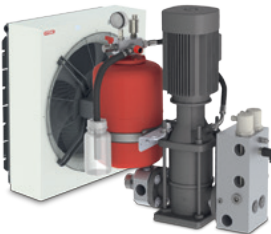

Inverter cooling

- Water glycol circuit with air cooler



Combined gearbox and generator cooling

Water glycol absorbs the heat of the generator and is then pumped through a plate heat exchanger, where it cools the gear oil. The water glycol is cooled by a cooling element that is exposed to the wind.

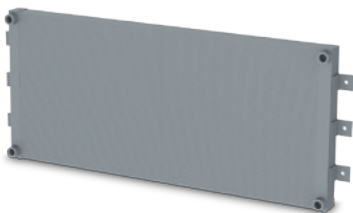



Passive cooling elements

When the cooling elements are positioned in the free air flow, the wind speed affects the level of fluid cooling.

see brochures no. 5.705 (Gearbox cooling systems)
5.706 (Water-Glycol circulation)

Air Coolers for Stationary Industrial Applications

	Model/description	Cooling capacity
	<p>AC-LN 1-7</p> <ul style="list-style-type: none"> ● Standard air cooler with axial fan <p>ACA-LN 2-7</p> <ul style="list-style-type: none"> ● Air cooler with pump <p>ACAF-LN 2-7</p> <ul style="list-style-type: none"> ● Air cooler with pump and filter <p>see brochure no. 5.816</p>	<p>1 – 50 kW</p>
	<p>AC-LN 8-14</p> <ul style="list-style-type: none"> ● Low-noise air cooler with axial fan <p>ACA-LN 8-11</p> <ul style="list-style-type: none"> ● Air cooler with pump <p>ACAF-LN 8-11</p> <ul style="list-style-type: none"> ● Air cooler with pump and filter <p>see brochure no. 5.814</p>	<p>50 – 200 kW</p>
	<p>AC-LN MI 8-14</p> <ul style="list-style-type: none"> ● Low-noise air cooler with axial fan ● With integrated frequency inverter ● Continuously adjustable speed-control in accordance with the fluid temperature in the cooling element ● Regulated cooling capacity <p>see brochure no. 5.817</p>	<p>50 – 230 kW</p>
	<p>OSCA/OSCAF 0-3</p> <ul style="list-style-type: none"> ● Optimized air cooler with radial fan ● OSCA: air cooler with pump ● OSCAF: air cooler with pump and filter <p>see brochure no. 5.811</p>	<p>1 – 16 kW</p>
	<p>OK-ELC 0-7</p> <ul style="list-style-type: none"> ● Oil/air cooler ● Compact motor-fan unit <p>see brochure no. 5.806</p>	<p>1 – 34 kW</p>
	<p>ATEX version</p> <ul style="list-style-type: none"> ● II 2G/D de IIC T4 ● For 50 Hz and 60 Hz ● Available for AC-LN, AC-LNH, OK-ELH <p>see brochure no. 5.819</p>	

Model/description

CPL – corrosion protection

- Three corrosion protection levels, CPL1/CPL2/CPLS, for various environmental conditions

see brochure no. 5.821

Accessories

- Integrated bypass valve with pressure or temperature function
- Thermostats
- Air filter grid/air filter mat
- Vibration damper
- Hydraulic and electric fan controllers

see brochure no. 5.822

Air Coolers for Mobile Applications

Model/description

Cooling capacity



OK-ELD 0-6

- Air cooler with DC motor (12 V and 24 V)
- Compact and performance-optimized
- Cooling of oils or coolants

see brochure no. 5.805

2 – 34 kW



OK-ELH 2-7 / AC-LNH 8-14

- Air cooler with hydraulic motor (6.3 – 22 cm³/U)
- Very low noise level
- Flexible use
- Cooling of oils or coolants

see brochures no. 5.808 (OK-ELH 2-7)
5.819 (AC-LNH 8-14)

2 – 140 kW





CMS – Cooling Mobile System

- Combination cooler for customized solutions
- Compact design
- Special cooling air fins or coating methods for use in dusty or aggressive environments
- Combination of several cooling circuits (coolant, charge air, hydraulic oil, gear oil, motor oil, fuel) possible in one cooler

see brochure no. 5.812



Plate Heat Exchanger

	Model/description
	<p>HYDAC HEX Sxxx</p> <ul style="list-style-type: none">● Brazed plate heat exchangers● Stainless steel plates vacuum-brazed with copper (standard) or nickel (for aggressive fluid) <p>see brochure no. 5.815</p>
	<p>Hxxx-LIQUID</p> <ul style="list-style-type: none">● Gasketed plate heat exchangers● Heat exchanger plates made from stainless steel or titanium● Gaskets: NBR, Viton, EPDM <p>see brochure no. 5.815</p>

Pump-Transfer Cooler Filtration Units

	Model/description	Cooling capacity
	<p>UF 2-3, UKF 1-3</p> <ul style="list-style-type: none">● UF = pump + filter● UKF = pump + heat exchanger + filter● Flow rate: up to 200 l/min <p>see brochure no. 5.405</p>	<p>up to 90 kW</p>
	<p>UKF 1-3 for gearbox applications</p> <ul style="list-style-type: none">● For cooling and lubrication of stationary gearboxes● With gear pump and filter● Flow rate up to 100 l/min <p>see brochure no. 5.423</p>	<p>up to 75 kW</p>

Feed Pumps

	Model/description	Pressure range
	FZP, MFZP <ul style="list-style-type: none">● (Motor) vane pump● In direct drive version● Output: 5 – 200 l/min see brochure no. 5.701	max. 6 bar
	VP, VPB, VPBM <ul style="list-style-type: none">● (Motor) vane pump● Low-noise series● Output: 30 – 200 l/min see brochure no. 5.702	max. 16 bar
 	Filling pumps <ul style="list-style-type: none">● For hydraulic oil or diesel fuel	

Cooling Systems

	Model/description	Cooling capacity
	<p>FLKS</p> <ul style="list-style-type: none"> ● Fluid/air cooling system ● Operating fluid water glycol or mineral oil ● Optionally with speed control <p>see brochure no. 5.818</p>	<p>up to 4.5 kW/K</p>
	<p>FWKS</p> <ul style="list-style-type: none"> ● Fluid/water cooling system ● Operating fluid water glycol or mineral oil ● Thermostatically or electronically controlled proportional valve or control ball valve available as an option <p>see brochure no. 5.618</p>	<p>up to 250 kW</p>
	<p>RFCS</p> <ul style="list-style-type: none"> ● Compressor cooling system ● To cool the fluid to ambient temperature or below <p>see brochure no. 5.824</p>	<p>up to 135 kW</p> <p>Higher cooling capacities possible as special design</p>
	<p>HCC</p> <ul style="list-style-type: none"> ● Control cabinet cooling system ● Passive or active cooling systems ● For roof installation or wall/door mounting <p>see brochure no. 5.825</p>	<p>up to 15 kW</p>

HYDAC Cooling Systems Provide Certainty Thanks to ...

Quality

In all the cooler components, priority is given to high quality standards. For this reason, our coolers undergo a series of tests before being released for market launch.

Reliability

As a high percentage of components are produced in-house for each product, high operational reliability is guaranteed. Our expertise in design, sales and service ensures that all functions are able to run smoothly.

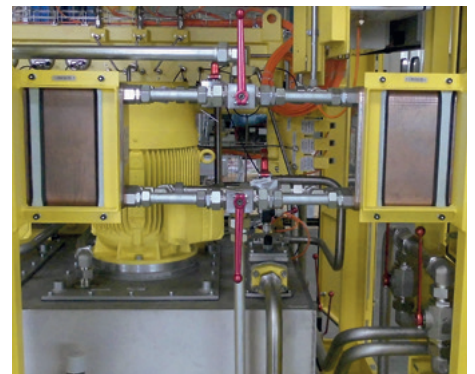

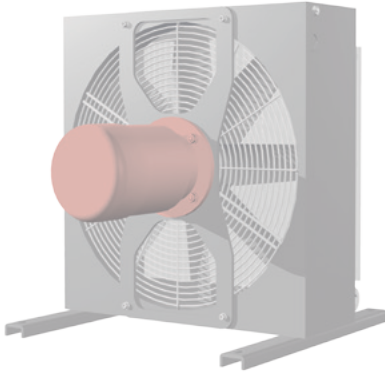

Air Coolers Industrial / Mobile

General

Air cooling is a simple means of dissipating heat, a by-product of the efficiency losses, within industrial and mobile machines.

The fluid – usually oil or water-glycol – flows through a cooler. A fan draws air and drives it through the cooling element. Thus, there is a temperature difference and heat exchange takes place resulting in an increase in air temperature which is then released in the environment.

This process reduces the average temperature of the fluid up to a few Celsius degrees over the actual environmental temperature.

It is possible to install an air cooler in almost every situation, with a minimum impact on the existing lay out.

The operating costs are correspondingly low and can be reduced further by using a speed-controlled fan. With new designs using special, low-noise fans and optimised air ducting we can also offer coolers with outstanding low noise emissions.

A wide range of coolers is available, with either axial and radial fan designs. AC, DC electric drives and hydraulic motors ensure versatility in catering to a variety of applications and ambient conditions.

Production, Test Rigs, Development

Cooling elements

The aluminium cooling elements are manufactured in our own HYDAC production plants. The cooling elements in 'plate and bar' construction demonstrate particularly impressive strength, design flexibility and optimal heat transfer.

We offer a large selection of air fin and fluid turbulator designs, ensuring radiators are tuned to provide maximum capacity in every situation – even in extremely contaminated environments.

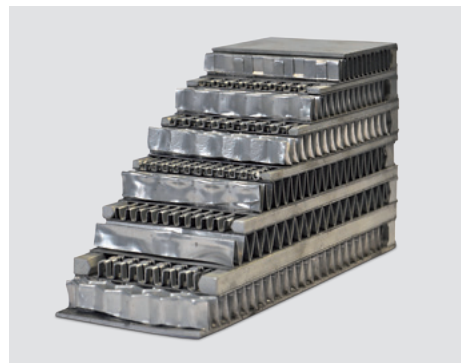

Example of different turbulators

Design of a cooling element

- High strength
- Versatile design
- Optimal heat transfer

Selection of air fins

Panel Cut [mm]

Herringbone [mm]

Herringbone Square Wave [mm]

COOLING PERFORMANCE ↑

ANTI-CLOGGING ↓

Industrial
Municipal Machines
Constructions Machines
Agricultural Machines

Production of cooling elements



Manufacturing of fins and turbulators



CNC tank machining



Radiator core assembly



Robot welding



CAB brazing furnace



Leakage test



Paint shop (powder coating)

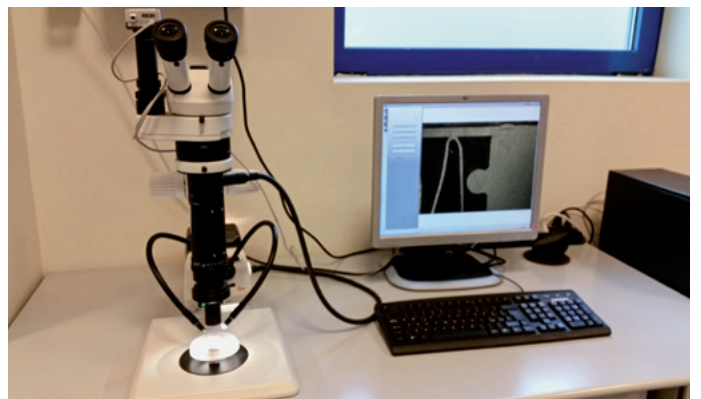

Quality inspection

Test rigs

Field measurements or tests carried out under real-life conditions are important methods to analyse the cooler performance and suitability for specific applications. Constancy and accuracy of the instruments used for measurements are essential requirements. Only in this way changes in the cooling system, e.g. the position of the fan in the fan housing, can be accurately quantified.

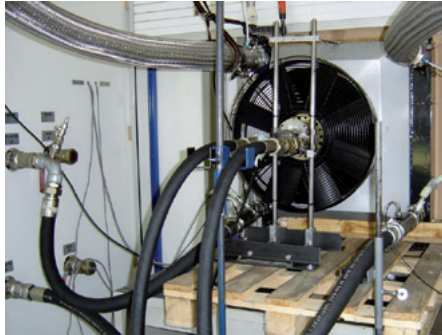

Test rigs for measuring cooling capacity with

- Hydraulic oil
- Gear oil
- Water glycol
- Charge air



Pressure pulsation test rigs

Oil coolers in the primary flow are particularly affected by changing pressure loads. Regular tests according to ISO / DIN 10771-1 are performed in order to validate a cooler for its area of application.

Further tests:

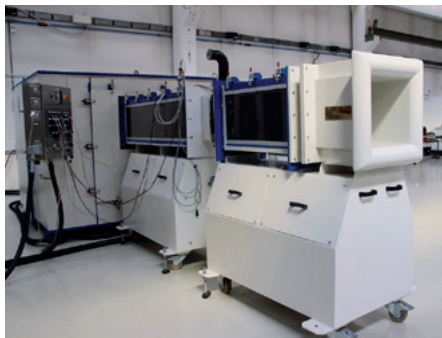

Wind tunnel

Carried out in order to determine the performance data of cooling element combinations and to provide a database for cooler calculation using the simulation software KULI.



Thermal shock test rig

To simulate extreme operating conditions in terms of temperature.

- Noise measurement
- Vibration tests
- Burst test
- Leakage test
- Corrosion tests in the salt spray chamber
- Cold chamber
- Thermal imaging camera

HYDAC test rigs fulfill all requirements in terms of testing accuracy and have been certified by TÜV Süd.



The test criteria and the testing equipment to be used are specified in the test procedures. The cooling capacity values indicated by HYDAC were derived following the specification EN 1048.

Development

Since product life cycles get shorter, it is necessary to develop multiple reliable versions of a new cooler design as soon as possible. Technical simulation plays an essential role here because it helps reduce development costs and times. Moreover, simulation as part of the development process results in more accurate design and optimization, long before the prototypes are produced. Last but not least, real-life tests can be kept to an absolute minimum.

With KULI software is possible to assess the heat management of a machine as a whole. But it can also be used to design individual coolers or heat exchangers. By simulating various heat balances of individual components based on the measurement data of a model heat exchanger in the wind tunnel, reliable coolers and cooling systems are the results.

In addition to KULI, computational fluid dynamics (CFD) are an important method to optimise coolers, heat exchangers and

cooling systems. Its purpose is to solve any given fluid dynamic or thermodynamic problem using numerical methods. For example, CFD can be used to analyse the effects of real, customer-specific installation situations on the cooler performance.

Finally the FEM method, i.e. the numerical analysis of problems in structural mechanics and thermal mechanics, is an important tool in development-stage simulation. Above all, it is used to assess structural stress and reduce hot spot stress in order to extend service life.

A team of development engineers by HYDAC works with the simulation methods depicted above in order to optimise existing components and systems and to identify new approaches to solutions, including custom solutions.

Kuli software
Rapid and accurate prediction of cooling capacities.

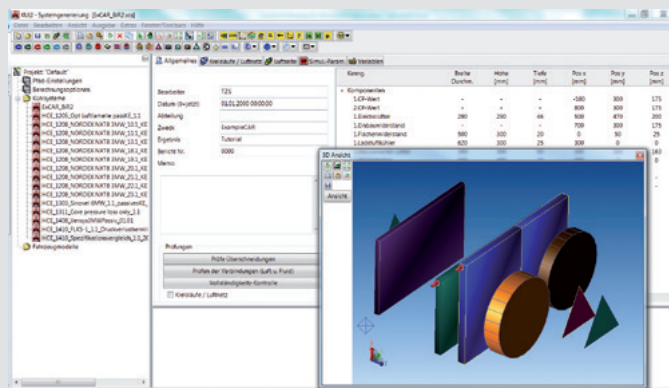

Simulations of passive cooling elements

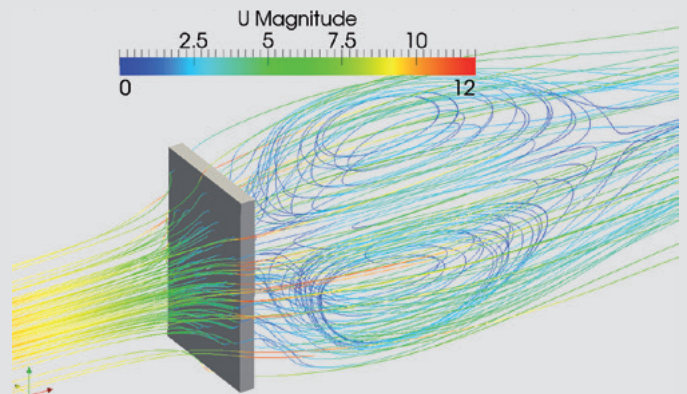

Simulations of complete air coolers

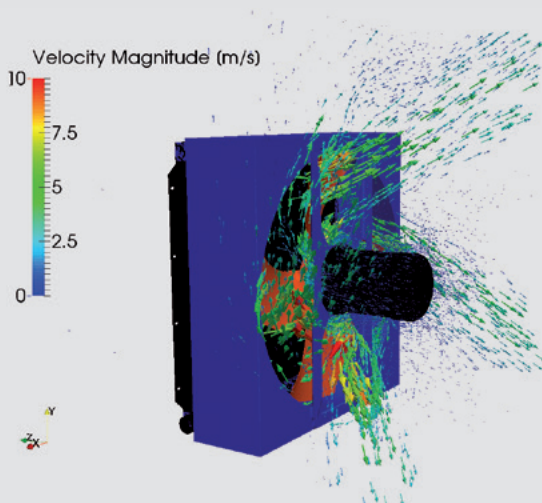

Simulations of air coolers in particular installation spaces

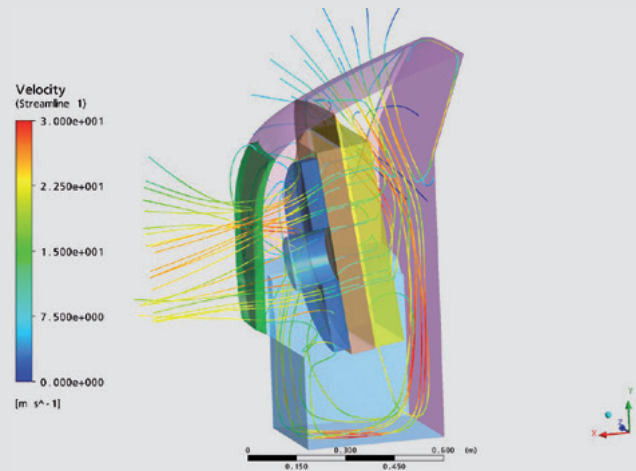



Air Coolers for all Applications ...

Industrial

		Cooling capacity	Medium: Mineral oil	Medium: Water glycol	Axial fan	Radial fan	With pump / pump + filter	Three-phase motor	DC motor	Hydraulic motor	Speed control	ATEX	Corrosion protection CPL
	AC-LN	up to 200 kW	•	•	•		•	•				•	•
	OSCA / OSCAF	up to 16 kW	•			•	•	•					
	OK-ELC	up to 34 kW	•	•	•			•*					
	AC-LN MI	up to 250 kW	•	•	•			•			•		•

* also available with single phase motor 230V-50Hz-1PH

Mobile

	OK-ELD	up to 34 kW	•	•	•				•		•		
	OK-ELH / AC-LNH	up to 140 kW	•	•	•					•	•	•	•
	Combination cooler CMS	To customer specification	Oil, water-glycol, fuel, charge air		•		•		•	•	•	•	•

... and all Industries

Industry



Steel

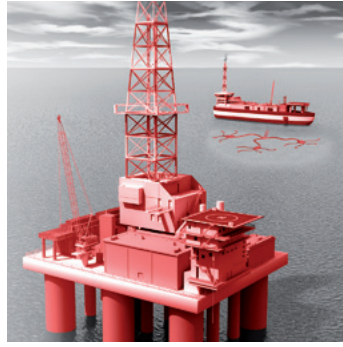

Oil & Gas

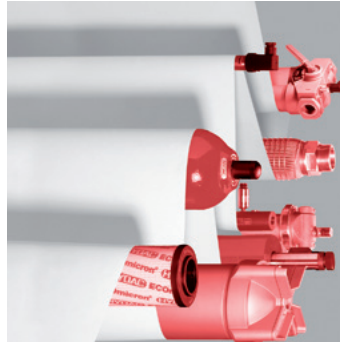

Paper industry

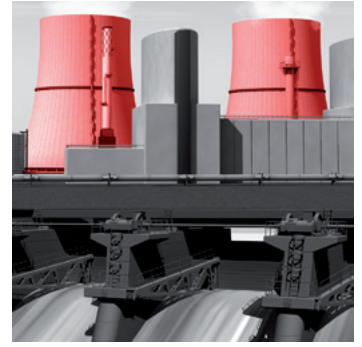

Thermal power plants



Hydro-electric power stations

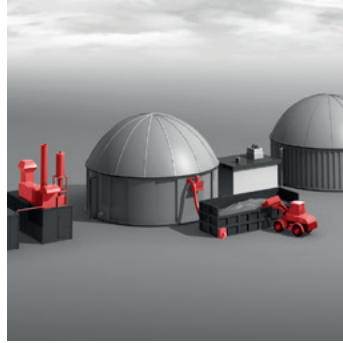

Biogas plants

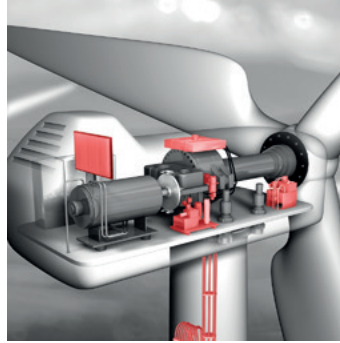

Wind turbines

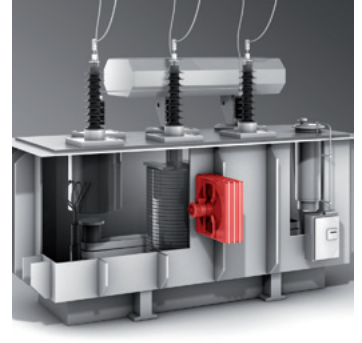

Transformers

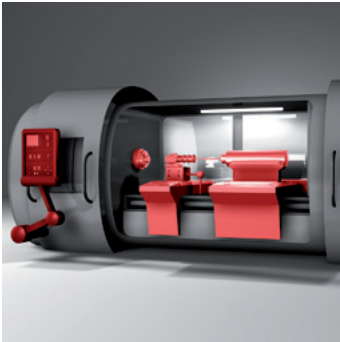

Machine tools

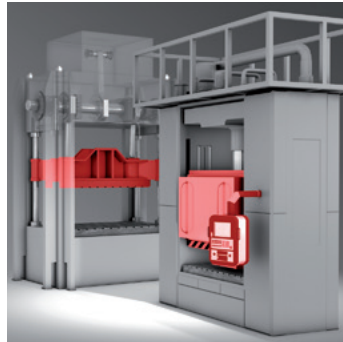

Presses

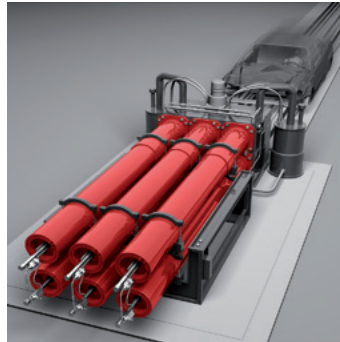

Test rigs



Marine

Mobile



Construction machines



Agricultural machines



Forestry machines



Municipal machines

Energy-efficient with the Energy Related Products (ErP) Directive

The purpose of the Energy Related Products (ErP) Directive 2009/125/EC is to reduce the energy consumption of these products and improve the environmental performance through Ecodesign. EU-wide standards are defined for each product group for this purpose.

All HYDAC coolers comply with the criteria of EU Directives.



Cooler Selection

The size of the cooler depends on various factors:

- the temperature difference between the medium and the ambient air
- the flow rate of the medium through the cooling element
- the flow rate of the air through the cooling element (fan speed)
- the design of the fins and turbulators

The following data is required for selecting the correct cooler:

- the cooling capacity required (power dissipation of the system)
- the medium to be cooled
- flow rate of the medium being cooled
- maximum medium inlet temperature into cooler
- maximum ambient air temperature (air temperature onto cooler)
- altitude and ambient conditions

If the required cooling capacity is not known, then it can either be calculated from the tank heat load or estimated from the installed electrical power.

Determining the Cooling Capacity from the Tank Heat Load

Designations:

P_v	Required dissipation, cooling capacity	[kW]
P_{01}	Specific cooling capacity	[kW/K]
V	Tank volume	[l]
δ_{Oil}	Density for mineral oil: 0.915	[kg/l]
CP_{Oil}	Specific heat capacity for mineral oil: 1.88	[kJ/kgK]
ΔT	Increase in temperature in the system	[°C]
t	Operating time	[min]
T_1	Oil temperature required	[°C]
T_2	Ambient temperature of the air	[°C]

In this case, the required dissipation is determined for systems and machines that are already in operation by first measuring the temperature increase in the medium over a defined time period (but before the temperature stabilises). The heat load of the system can be determined from the available data.

Example:

The oil temperature in a system increases from 20 °C to 60 °C over a period of 30 minutes, the tank capacity is 400 l.

Calculation of the cooling capacity:

V	400	[l]
ΔT	(60-20) = 40	[°C]
t	30	[min]

$$P_v = \frac{\Delta T_{Oil} \times cp_{Oil} \times \delta_{Oil} \times V_{Oil}}{t \times 60} = \frac{40 \times 1.88 \times 0.915 \times 400}{30 \times 60} = 15.30 \text{ [kW]}$$

Calculation of the specific cooling capacity:

T_1	60	[°C]
T_2	30	[°C]

$$P_{01} = \frac{P_v}{T_1 - T_2} = \frac{15.3}{60 - 30} = 0.51 \text{ [kW/K]}$$

With 5 % safety margin (to allow for contamination), the specific cooling capacity

$$P_{01} \times 1.05 = 0.53 \text{ [kW/K]}$$

Estimating the cooling capacity from the installed electrical power

If the plant is not yet in operation, then the expected heat load can also be estimated: without throttling, it is approx. 15 – 20 % of the drive power, with throttling, it is up to 30 % of the drive power.

Selecting the Correct Size

This heat load must be dissipated by an air cooler. The suitable size can now be selected in the diagram.

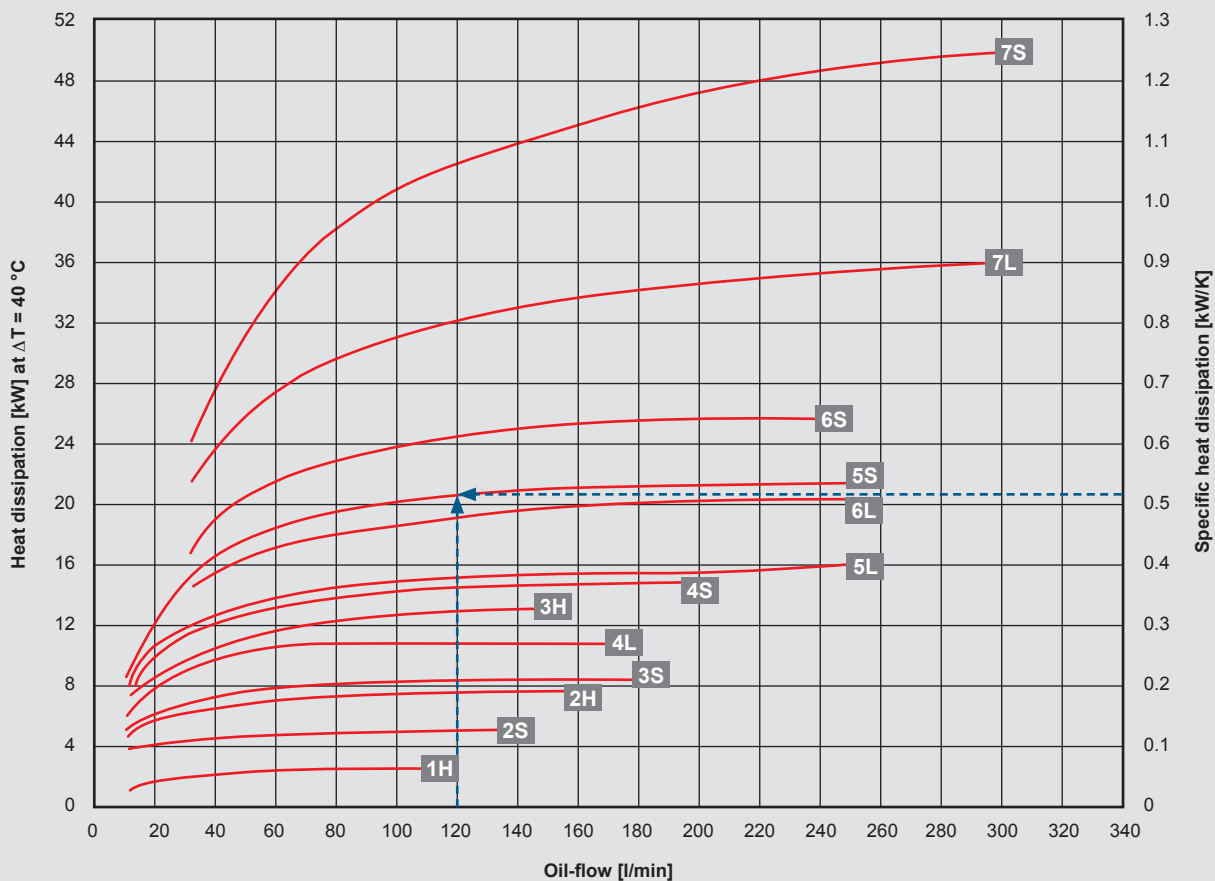

Tolerance: $\pm 5\%$

Sizing Software

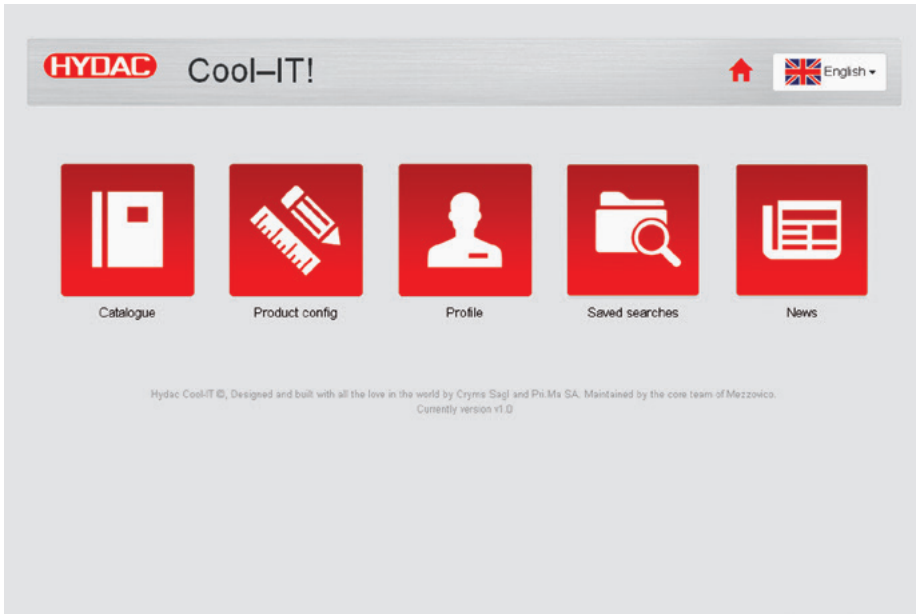

Our design software, HYDAC Cool IT, was developed in order to speed up and simplify selection from the HYDAC air cooler range.

You can also use our Specification sheet for air coolers in order to ensure you have all of the necessary data to hand.

Contact our Technical Sales Office for further details.

Specification Sheet for Air Coolers

Please contact the Technical Sales Office for your customised combination cooler (CMS) design.

Project: _____

Contact: _____

Telephone: _____

E-mail: _____

Application: _____

The cooler is installed in return line offline

Version: without pump with pump with pump + filter

Motor type: AC 400V-50Hz-3Ph 230V-50Hz-1Phe 100V-50Hz-1Ph

DC 12 V 24 V

HY 6.3 cc 14.0 cc 22.0 cc

Other _____

If known: Cooler type _____

Design data

Medium: _____

Flow rate through the cooler: _____ l/min

Max. temperature in the oil circuit: _____ °C Cooler inlet temperature

Max. ambient temperature (air): _____ °C

Required cooling capacity: _____ kW

Target temperature after cooler: _____ °C

Tank volume of the storage tank: _____ ltr

Operating pressure: _____ bar

Max. permitted pressure loss _____ bar

Version

Max. possible unit dimensions: _____ mm H x W x D

Max. noise level: _____ dB(A)

Accessories: Thermostat, adjustable (AITR) Thermostat, fixed (AITF)

Integrated thermal pressure bypass (IBT) Integrated pressure bypass (IBP)

Air filter grille Air filter meshpack

Vibration mounts _____

Notes/Miscellaneous:

Specification Sheet AC-LN 8-14 MI with Speed Control

Project: _____

Contact: _____

Phone: _____

E-mail: _____

Application: _____

Cooler type: _____

Data required

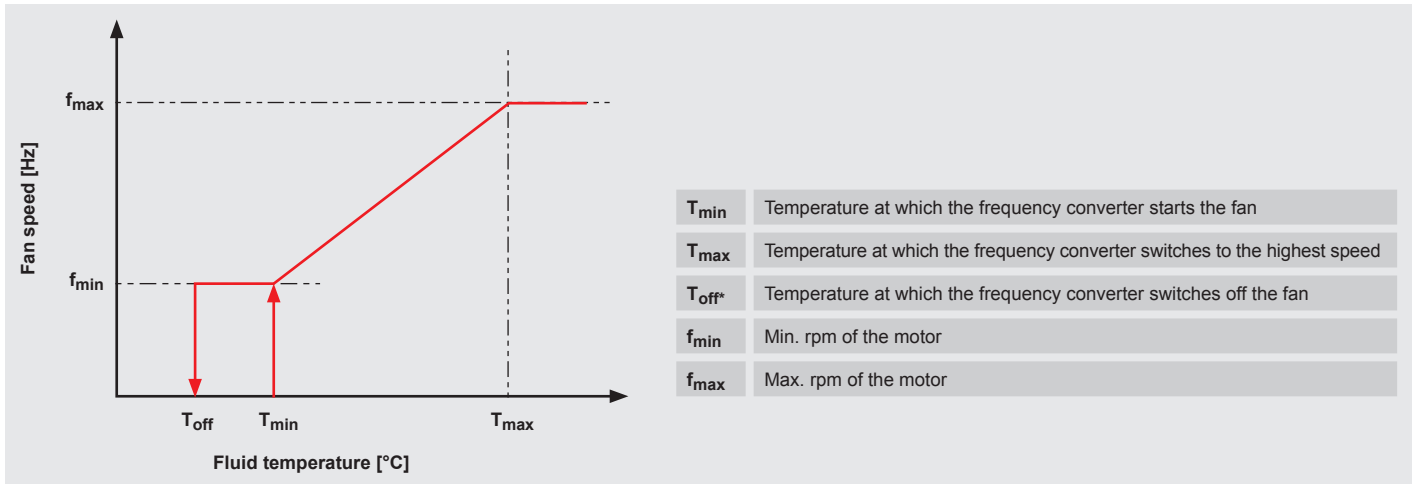

Motor 1

T_{min} _____ °C

f_{min} _____ rpm

T_{max} _____ °C

f_{max} _____ rpm

T_{off} _____ °C

Motor 2 (AC-LN 12 MI / AC-LN 14 MI)

T_{min} _____ °C

f_{min} _____ rpm

T_{max} _____ °C

f_{max} _____ rpm

T_{off} _____ °C

Note

The temperature must be between +20 °C and +85 °C.

Min. speed: 200 min⁻¹

Max. permitted speed AC-LN 8, 9, 10 and 12 MI: 1,720 min⁻¹

AC-LN 11 and 14 MI: 1,500 min⁻¹

* T_{off} :

Ensure a slight hysteresis between T_{min} and T_{off} in order to prevent the fan switching on and off continuously at low temperatures. The hysteresis will vary depending on the environment and the system, usually a few degrees Celsius is sufficient.

Note

The information in this brochure relates to the operating conditions.

For applications and operating conditions not described, please contact the relevant technical department.

Subject to technical modifications.



HYDAC COOLING GMBH

Industriegebiet
66280 Sulzbach/Saar
Germany

Tel.: +49 6897 509-01
Fax: +49 6897 509-454

E-mail: cooling@hydac.com
Internet: www.hydac.com

**HYDAC AG
Mezzovico Branch**

Via Sceresca, Zona Industriale 3
6805 Mezzovico
Switzerland

Tel.: +41 91 9355-700
Fax: +41 91 9355-701

E-mail: info@hydac.ch
Internet: www.hydac.com



Air Cooler Industry

AC-LN 1-7 / ACA-LN 2-7 / ACAF-LN 2-7

Symbol

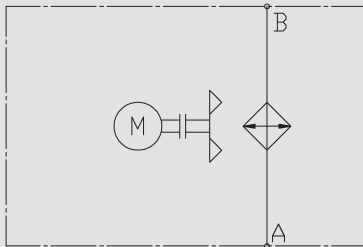

General

The AC-LN 1-7 air cooler series can be used in all areas where either oil or water-glycol is to be cooled with air. The coolers with an axial fan can be used in the return line as well as in the bypass flow.

The wide range of accessories and optional versions mean that the coolers can be adapted flexibly to various applications.

Product Features

The cooler can also be used in the bypass flow by attaching a pump. An additional filter enables continuous filtration of the medium.

- Large product range
- Large cooling performance range
- Modular design

Operation Data

Fluids	Oils (mineral oils, synthetic oils, high viscosity oils, biological oils, phosphate ester) Water-glycol (cooling fluid) HFC pressure fluids
Viscosity	AC-LN: 2,000 mm ² /s (standard) ACA-LN / ACAF-LN: see technical data
Temperature range	Minimum / maximum ambient temperature: -20 °C to +40 °C (standard) Minimum / maximum temperature of the medium: +130 °C Please contact the technical sales department in the event of deviating temperatures for applications with water-glycol. Notice! Fan switching frequency at max. fan speed (max. volume of air) must be avoided when operating a cooler at which the temperature difference between the medium inlet at the cooler and the ambient temperature can be greater than +50 °C. Quick changes in the temperature of the cooling element material can lead to a significant reduction in service life or to direct damage of the cooling element due to thermal shock. Please contact the technical sales department to receive information about controlled fan drives.
Pressure resistance of the cooling element	Dynamic operating pressure: 16 bar Static operating pressure: 21 bar
Fan	Axial fan in suction version (standard) Axial fan in pushing version on request (note: approx. 10 % less cooling capacity)
Motor	Three-phase motor Efficiency class IE2 (only ≥ 0.75 kW) Protection class IP55 Insulation class F Other versions on request.
ErP	The fan unit of the AC-LN corresponds to the minimum efficiency levels specified in the Ecodesign directive or ErP directive (Energy-related Products) 2009/125/EC.
Pump (only ACA-LN/ACAF-LN)	ACA-LN / ACAF-LN 2-3: screw pump ACA-LN / ACAF-LN 4-5-6: vane pump ACA-LN / ACAF-LN 7: screw pump with separate motor Operating pressure: max. 10 bar (screw pump) max. 6 bar (vane pump) Negative suction pressure of the pump: max. -0.4 bar Pump motor speed: 3,000 rpm
Noise levels	See technical data AC-LN and ACA-LN / ACAF-LN The noise levels are only reference values as the acoustic properties of a room, connections and reflection have an effect on the noise level.
Accessories	Integrated pressure bypass valve (IBP) or integrated thermal pressure bypass valve (IBT) (cannot be retrofitted, also see options) Thermostats Air filter grid or air filter mat Vibration damper

Application Field

Systems with small and medium cooling requirements, such as:

- Hydraulic systems
- Lubrication systems
- Gears
- Motors
- Generators
- Converters
- Machine tools

Options

Integrated pressure bypass valve (IBP) / Integrated thermal pressure bypass valve (IBT)

The bypass channel is integrated in the cooling element. If a particular pressure is exceeded, the IBP opens the bypass channel, thereby protecting the cooling element from too high a pressure. Furthermore, the IBT only opens the cooling element path once a particular temperature has been reached.

ATEX

The AC-LN (without pump and filter) is also available for operation in gas and dust explosive areas. The ATEX certification applies for a frequency of 50 Hz and 60 Hz.

Marine

The MAR version is for aggressive ambient conditions, such as industrial atmospheres, high humidity or high salt content, which place great demands on the corrosion resistance and robustness of the materials used.

Cold Climate/Hot Climate

Use in extreme ambient conditions:
Cold Climate to -40 °C,
Hot Climate to +60 °C

The various versions can also be combined. Our technical sales department will be happy to assist you further.

Design

AC-LN 1

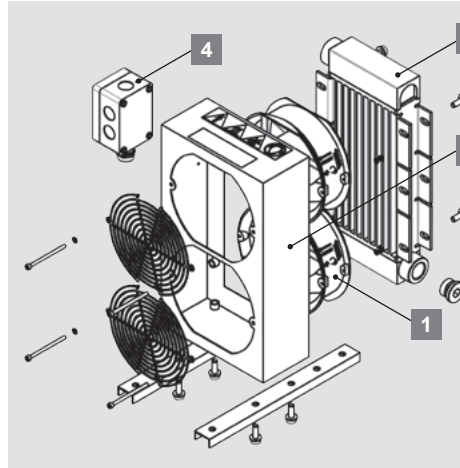
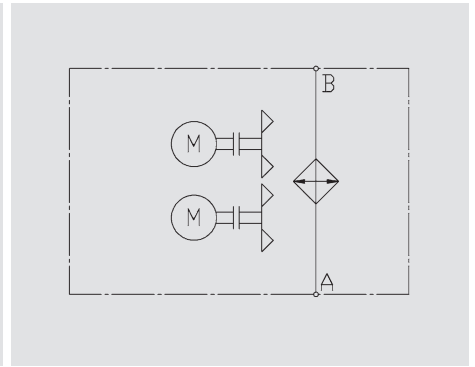
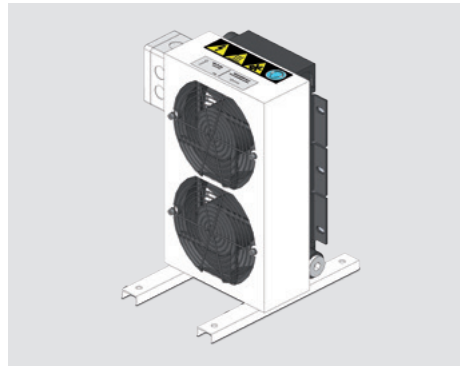

- | | |
|---|---------------------------------|
| 1 | Axial fan with integrated motor |
| 2 | Fan housing |
| 3 | Heat exchanger |
| 4 | Electrical box |

AC-LN 2-3-4-5-6

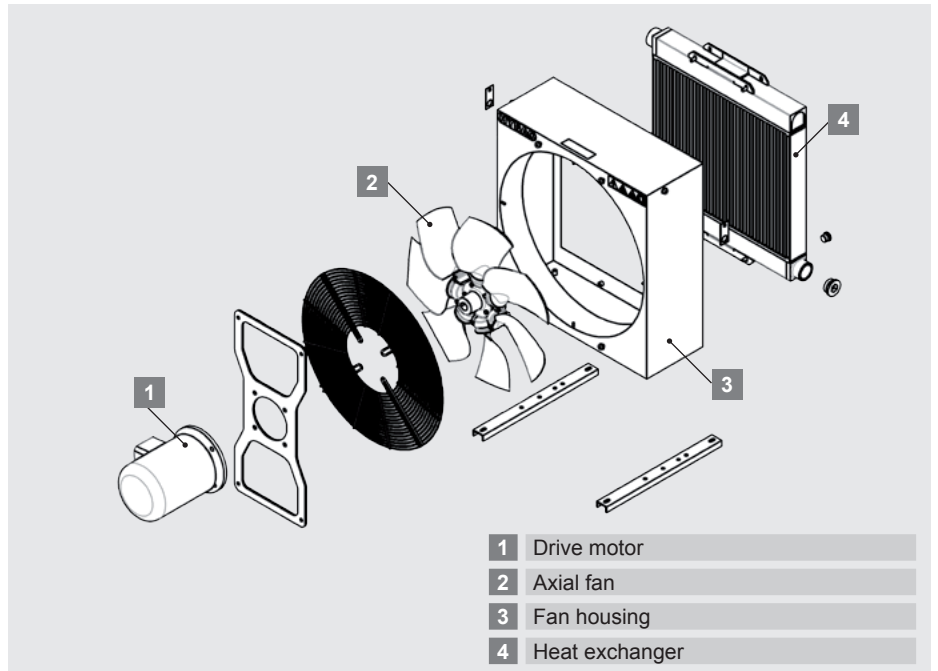
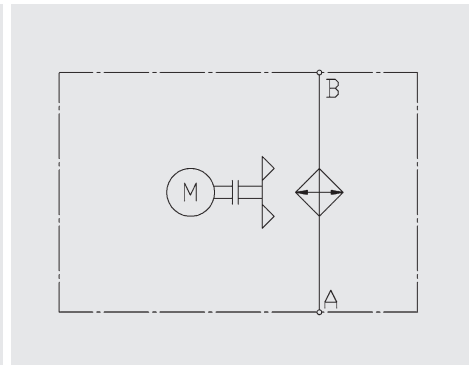

- | | |
|---|----------------|
| 1 | Drive motor |
| 2 | Axial fan |
| 3 | Fan housing |
| 4 | Heat exchanger |

Design

AC-LN 7

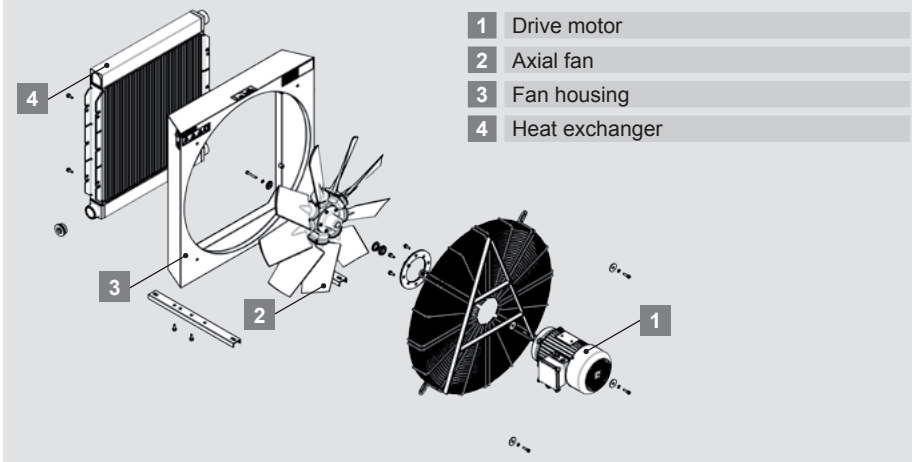
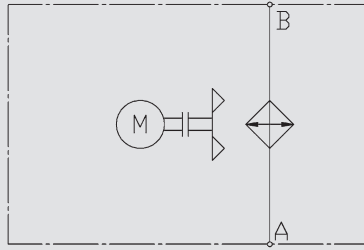
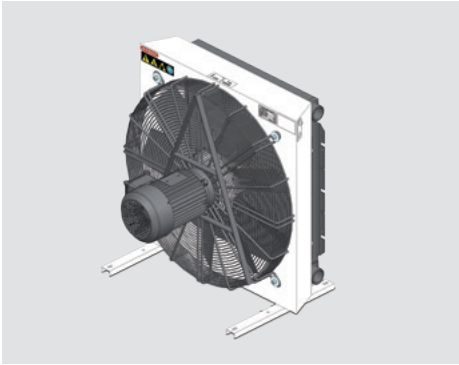

ACA-LN 2-6

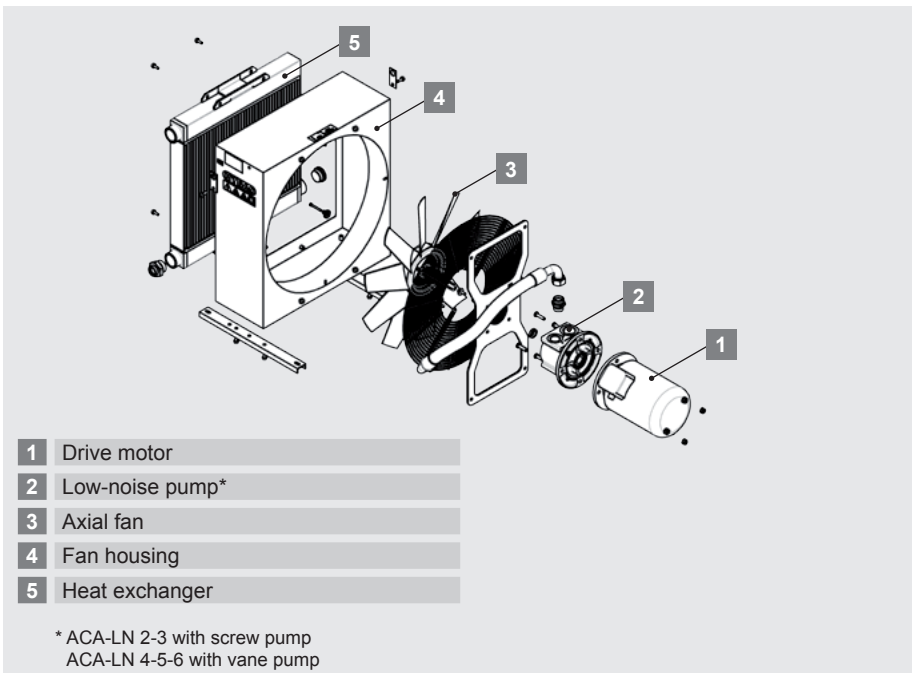
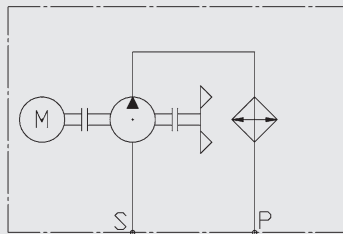
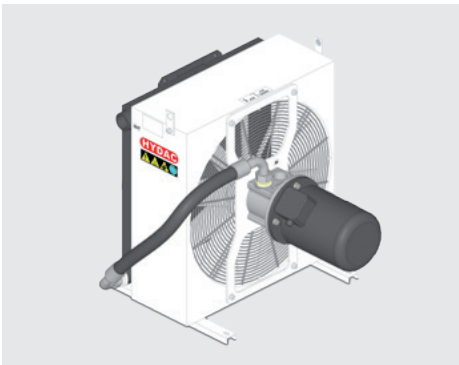

Design

ACA-LN 7

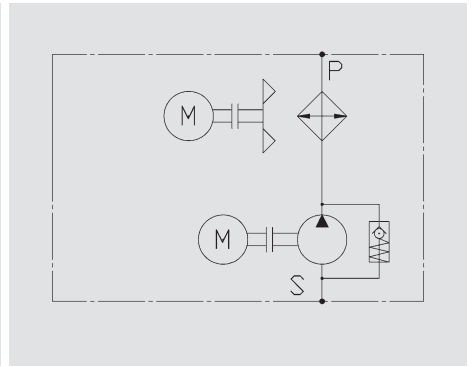
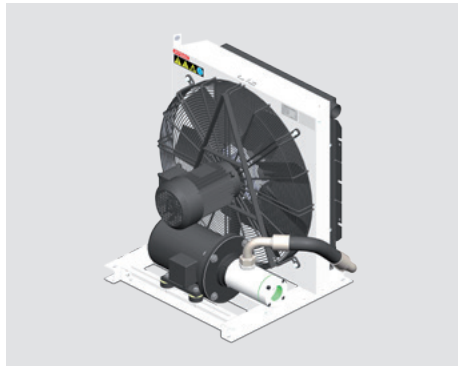

- 1 Drive motor
- 2 Axial fan
- 3 Low-noise screw pump
- 4 Fan housing
- 5 Heat exchanger

With external motor-pump assembly attached onto the base frame.

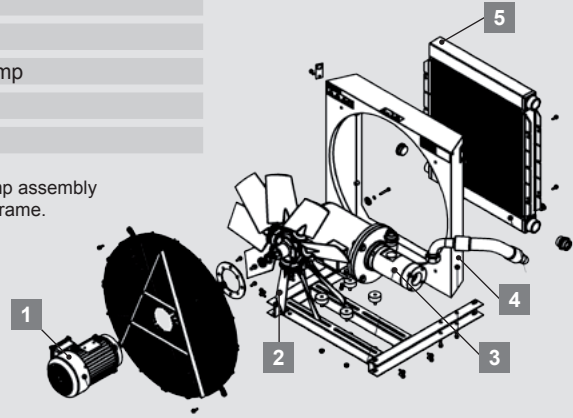

ACAF-LN 2-6

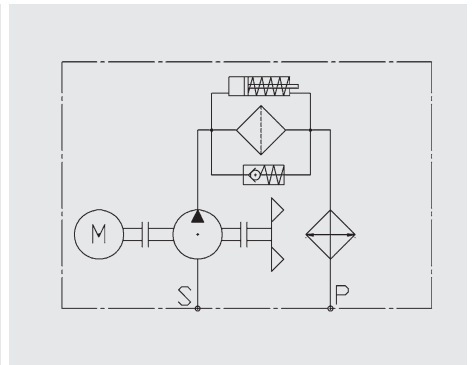
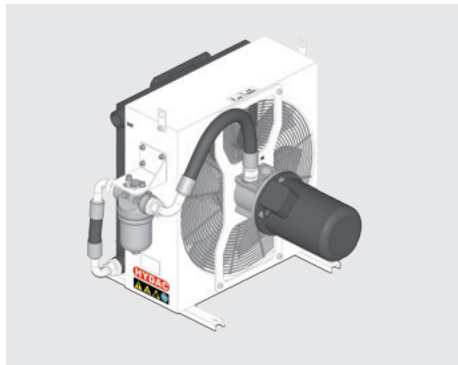

- 1 Drive motor
- 2 Low-noise pump*
- 3 Axial fan
- 4 Fan housing
- 5 Heat exchanger
- 6 Filter

* ACAF-LN 2-3 with screw pump
 ACAF-LN 4-5-6 with vane pump
 The filter is equipped with a visual clogging indicator as standard.

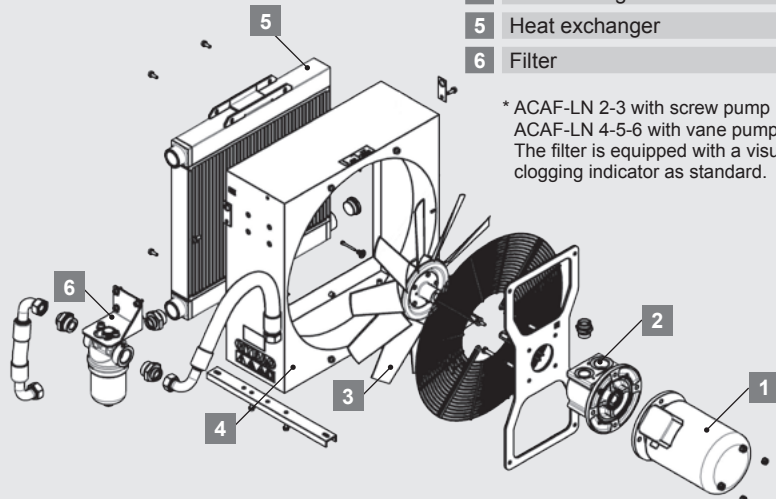

Design

ACAF-LN 7

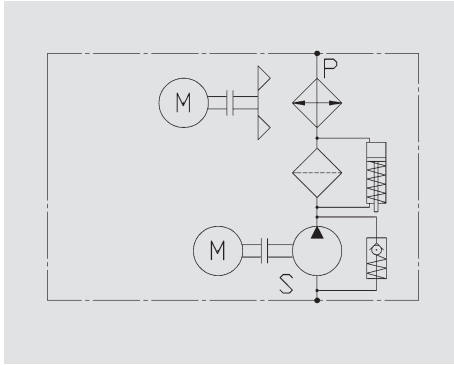
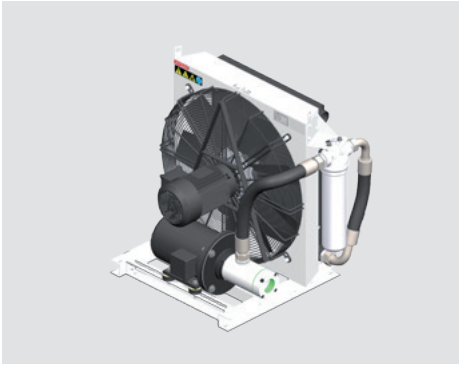

- 1 Drive motor
- 2 Axial fan
- 3 Low-noise screw pump
- 4 Fan housing
- 5 Heat exchanger
- 6 Filter

With external motor-pump assembly attached onto the base frame. The filter is equipped with a visual clogging indicator as standard.

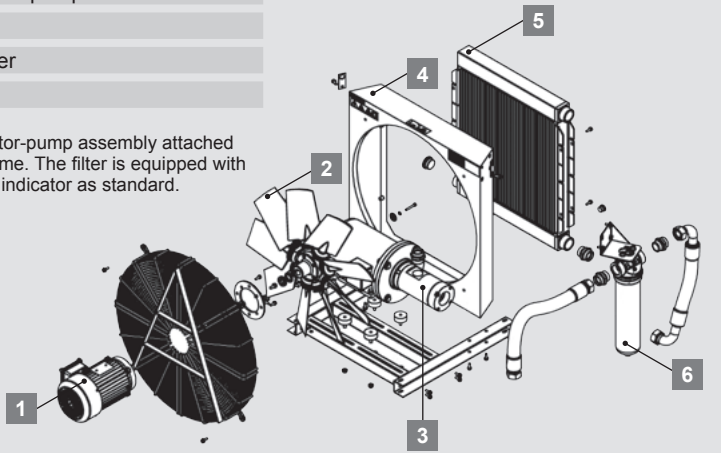

Technical Data

AC-LN

Type of cooler	P/N	Fluid [°] ⁽¹⁾	Fluid flow [l/min] ⁽²⁾	Air flow [m ³ /h] ⁽³⁾	Fan motor: Poles / size / flange	Fan motor 50 Hz: Power / current absorption [kW / A] ⁽⁴⁾		Fan motor 60 Hz: Power / current absorption [kW / A] ⁽⁴⁾		Noise level (at 1 m distance, 50 Hz) [dB(A)]	Volume [l] ⁽⁵⁾	Weight [kg] ⁽⁶⁾
						kW	A	kW	A			
AC-LN1H	3849085	F	120	650	-	0.03	0.23	0.03	0.21	60	0.3	7
AC-LN2S	3860765	F	180	900	4/63/B5	0.18	0.66	0.20	0.75	64	0.7	14
AC-LN2H	3860702	F	180	1,850	2/63/B5	0.25	0.76	0.30	0.76	80	0.7	14
AC-LN3S	3860382	F	180	1,400	4/63/B5	0.18	0.66	0.20	0.75	66	1.0	20
AC-LN3H	3860308	F	180	2,900	2/71/B14	0.55	1.21	0.66	1.50	85	1.0	20
AC-LN4L	3859982	F	200	1,600	6/71/B5	0.25	0.90	0.28	0.80	63	2.3	32
AC-LN4S	3860090	F	200	2,250	4/71/B5	0.37	1.20	0.40	1.10	72	2.3	32
AC-LN5L	3860913	F	250	2,050	6/80/B5	0.37	1.25	0.41	1.15	65	2.8	42
AC-LN5S	3860907	F	250	3,200	4/90/B5	1.10	2.60	1.30	2.20	75	2.8	45
AC-LN6L	3856579	F	250	2,800	6/80/B5	0.37	1.25	0.41	1.15	67	4.6	52
AC-LN6S	3859080	F	250	4,250	4/90/B5	1.10	2.60	1.30	2.20	77	4.6	52
AC-LN7L	3909026	F	300	4,800	6/90/B14	1.10	2.70	1.30	2.70	76	5.2	58
AC-LN7S	3909027	F	300	8,200	4/100/B14	3.00	6.00	3.60	7.20	84	5.2	63

¹⁾ Medium: F = mineral oil or water-glycol, M = mineral oil

²⁾ Max. flow rate

³⁾ Air flow data at 50 Hz

⁴⁾ AC-LN1: each motor

⁵⁾ Fluid in cooling element

⁶⁾ Unfilled

Technical Data

ACA-LN / ACAF-LN

Type of cooler	Fluid [-] ¹⁾	Fluid flow [l/min] ²⁾	Air flow [m ³ /h] ²⁾	Pump displacement [cm ³ /U]	Max. Viscosity [mm ² /s] continuous working ³⁾	Fan motor: Poles / size / flange	Fan motor 50 Hz: power / current absorption [kW / A] ⁴⁾		Fan motor 60 Hz: power / current absorption [kW / A] ⁴⁾		Filter size [-]	Noise level (at 1m distance, 50 Hz) [dB(A)]	Volume [l] ⁵⁾	Weight [kg] ⁶⁾
							kW	A	kW	A				
ACA-LN2S	M	13	900	10	500	4/71/B5	0.37	1.20	0.40	1.10	-	64	0.7	21
ACA-LN2H	M	27	1,850	10	500	2/80/B5	1.50	3.10	1.80	3.10	-	80	0.7	21
ACAF-LN2S	M	13	900	10	500	4/71/B5	0.37	1.20	0.40	1.10	LPF160	64	0.7	22
ACAF-LN2H	M	27	1,850	10	500	2/80/B5	1.50	3.10	1.80	3.10	LPF160	80	0.7	22
ACA-LN3S	M	36	1,400	28	500	4/90/B5	1.10	2.60	1.30	2.60	-	66	1.0	35
ACA-LN3H	M	72	2,700	28	500	2/90/B5	2.20	4.50	2.6	4.5	-	85	1.0	35
ACAF-LN3S	M	36	1,400	28	500	4/90/B5	1.10	2.60	1.30	2.60	LPF160	66	1.0	36
ACAF-LN3H	M	72	2,700	28	500	2/90/B5	2.20	4.50	2.6	4.5	LPF160	85	1.0	36
ACA-LN4L	M	24/34	1,600	28/40	350	6/90/B5	1.10	2.65	1.30	2.25	-	63	2.3	35
ACA-LN4S	M	36/52	2,250	28/40	350	4/90/B5	1.80	3.70	2.10	3.60	-	72	2.3	35
ACAF-LN4L	M	24/34	1,600	28/40	350	6/90/B5	1.10	2.65	1.30	2.25	LPF160	67	2.3	41
ACAF-LN4S	M	36/52	2,250	28/40	350	4/90/B5	1.80	3.70	2.10	3.60	LPF160	72	2.3	41
ACA-LN5L	M	24/34	2,050	28/40	350	6/90/B5	1.10	2.65	1.30	2.25	-	65	2.8	45
ACA-LN5S	M	36/52	3,200	28/40	350	4/90/B5	1.80	3.70	2.10	3.60	-	75	2.8	45
ACAF-LN5L	M	24/34	2,050	28/40	350	6/90/B5	1.10	2.65	1.30	2.25	LPF160	65	2.8	52
ACAF-LN5S	M	36/52	3,200	28/40	350	4/90/B5	1.80	3.70	2.10	3.60	LPF160	77	2.8	52
ACA-LN6L	M	24/34	2,800	28/40	350	6/90/B5	1.10	2.65	1.30	2.25	-	67	4.6	55
ACA-LN6S	M	36/52	4,250	28/40	350	4/90/B5	1.80	3.70	2.10	3.60	-	77	4.6	55
ACAF-LN6L	M	24/34	2,800	28/40	350	6/80/B5	1.10	2.65	1.30	2.25	LPF160	67	4.6	62
ACAF-LN6S	M	36/52	4,250	28/40	350	4/90/B5	1.80	3.70	2.10	3.60	LPF160	77	4.6	62
ACA-LN7L	M	100/150/180	4,800	40/58/69	320/130/240	6/90/B14	1.10	2.70	1.30	2.70	-	76	5.2	74
ACA-LN7S	M	100/150/180	8,200	40/58/69	320/130/240	4/100/B14	3.00	6.00	3.60	7.20	-	84	5.2	74
ACAF-LN7L	M	100/150/180	4,800	40/58/69	320/130/240	6/90/B14	1.10	2.70	1.30	2.70	LPF280	76	5.2	82
ACAF-LN7S	M	100/150/180	8,200	40/58/69	320/130/240	4/100/B14	3.00	6.00	3.60	7.20	LPF280	84	5.2	82

¹⁾ Medium: F = mineral oil or water-glycol, M = mineral oil

²⁾ Fluid and air flow data at 50 Hz

³⁾ Depends on pump displacement

⁴⁾ For the size 7 the power / current absorption data are those of the fan motor.

For the pump motor on feet refer to the following data:

40/58 cm³/U → 3 [kW] / 6.7 [A]

69 cm³/U → 5.5 [kW] / 10.4 [A]

⁵⁾ Fluid in cooling element

⁶⁾ Unfilled

Cooling in bypass flow: ACA-LN / ACAF-LN

The ACA-LN with integrated boost pump is a complete bypass flow cooling system; the ACAF-LN is equipped with a high-quality HYDAC filter for additional filtration.

Advantages:

- Stable cooling and filtration (independent of the cycle times of the system)
- Continuous filtration is possible, cooling as required
- Avoidance of pressure surges in the cooling element
- Design of the cooler is in accordance with the cooling capacity required (not according to the maximum possible return flow volume)

Cooling Capacity and Pressure Difference Δp

Mineral oil

AC-LN / ACA-LN / ACAF-LN

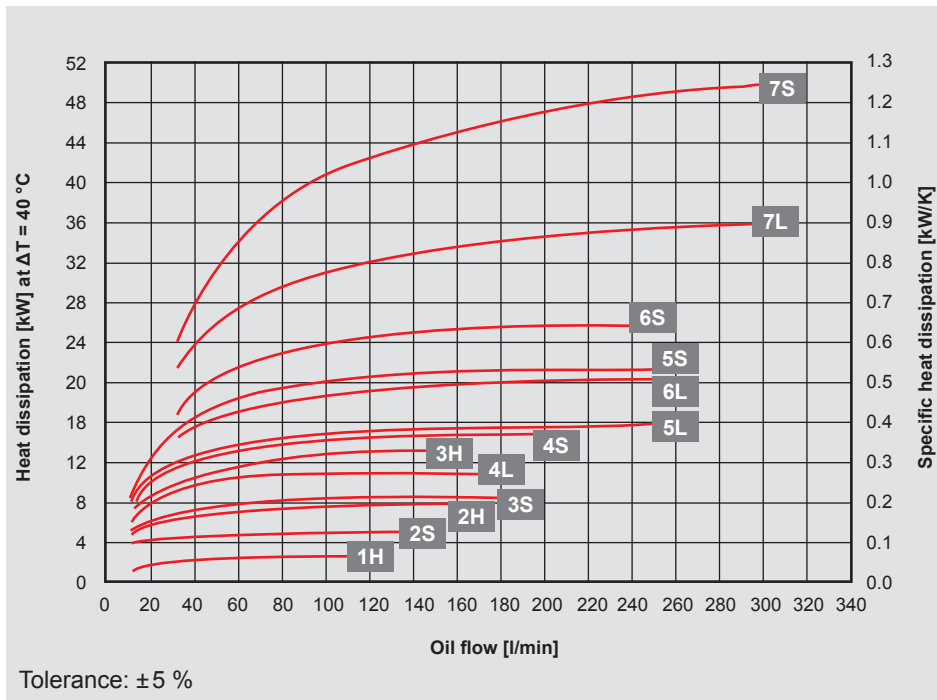

Cooling capacity:

Dependent on the oil flow rate and the temperature difference ΔT between oil inlet and air inlet.

Note:

The values are measured at $\Delta T = 40^\circ\text{C}$. For smaller ΔT values, the values can change. You can also use our cooler calculation software for designing. Please contact our technical sales department.

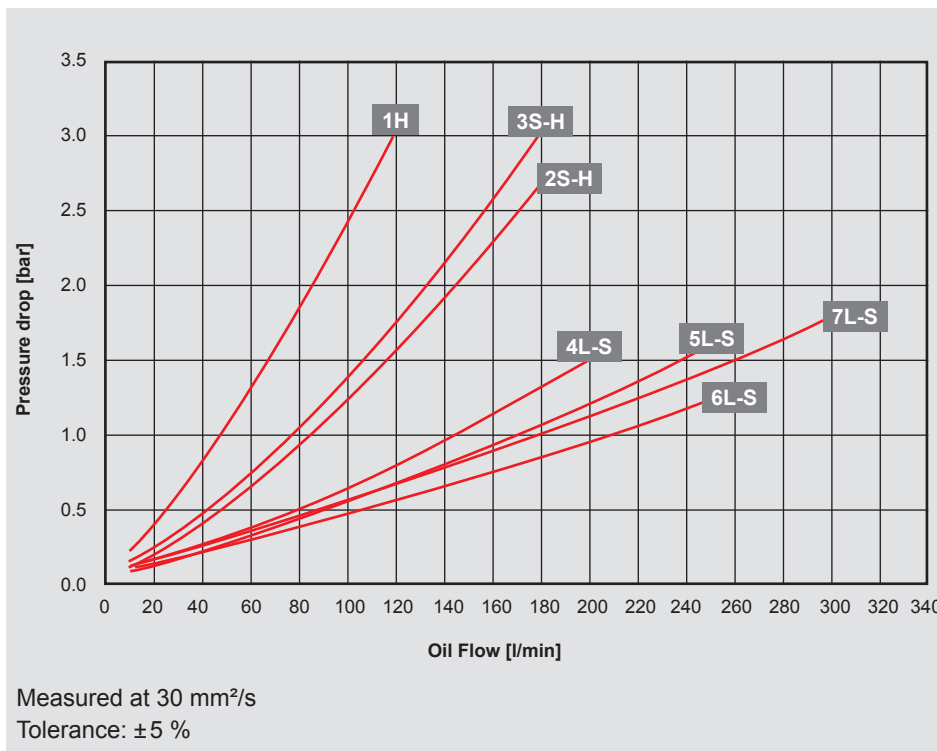

Pressure difference Δp

For other viscosities, the pressure loss must be multiplied by the conversion factor K:

Viscosity (mm^2/s)	10	15	22	30	46	68	100	150
Factor K	0.35	0.5	0.75	1	1.4	1.9	2.5	3.5

Cooling Capacity and Pressure Difference Δp

Water-glycol (60/40)

AC-LN

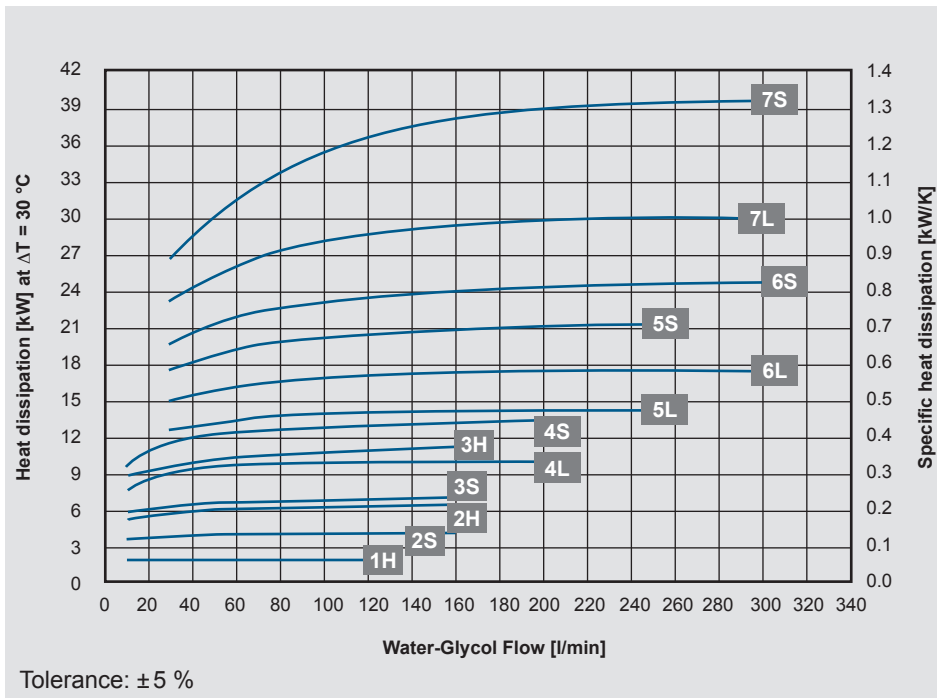

Cooling capacity:

Dependant on the water-glycol flow rate and the temperature difference ΔT between w/g inlet and air inlet.

Note:

The values are measured at $\Delta T = 30\text{ °C}$. For smaller ΔT values, the values can change. You can also use our cooler calculation software for designing. Please contact our technical sales department.

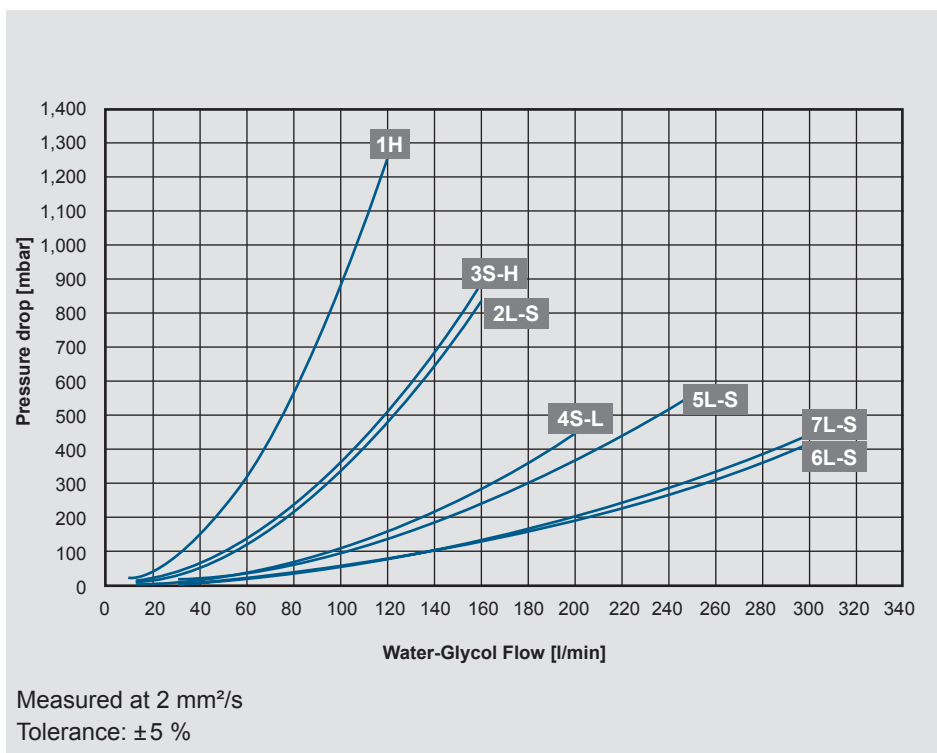

Pressure difference Δp

Measured at $2\text{ mm}^2/\text{s}$

Tolerance: $\pm 5\%$

Model Type

ACAF-LN 4S - 40 - 1.0 - B - M - A - LPF160 - 10 - 1 - IBT

Cooler type

- AC-LN = Air cooler (oil / water-glycol mix)
- ACA-LN = Air cooler (oil) with integrated pump
- ACAF-LN = Air cooler (oil) with integrated pump and filter

Size / motor speed

- 1-7 = Size
- L = 6 poles (1,000 rpm)
- S = 4 poles (1,500 rpm)
- H = 2 poles (3,000 rpm)

Displacement cm³/rev

- 10 = Screw pump (ACA-LN / ACAF-LN2)
- 28 = Screw pump (ACA-LN / ACAF-LN3)
- 28 = Vane pump (ACA-LN / ACAF-LN4-6)
- 40 = Vane pump (ACA-LN / ACAF-LN4-6)
- 40/58/69 = Screw pump (ACA-LN / ACAF-LN 7)

Revision

Clogging indicators (only ACAF-LN)

- A = Without clogging indicator
- B = With visual indicator (Standard)
- D = With electrical and optical indicator

Fluids

- F = Mineral oil or water glycol mix (AC-LN)
- M = Mineral oil (ACA-LN and ACAF-LN)

Motor voltage

Standard voltages and frequencies for 3 phase motor

- A = 230/400 V – 50 Hz / 265/460 V – 60 Hz
 - B = 230/400 V – 50 Hz
 - C = 265/460 V – 60 Hz
 - AC-LN1 = 220-240 V – 50/60 Hz, single phase (Standard)
- (tolerance voltage ± 10 %)
Other voltages on request.

Size of filter (only ACAF-LN)

- LPF160 = ACAF-LN2-6
- LPF280 = ACAF-LN7

Filtration rating in micron (only ACAF)

- 5 = 5 µm Betamicon®-4-N (5 BN4HC)
- 10 = 10 µm Betamicon®-4-N (10 BN4HC) (Standard)
- 20 = 20 µm Betamicon®-4-N (20 BN4HC)

Color

- 1 = RAL 9002 (Standard)
- Other colors on request.

Accessories

- IBP = Heat exchanger with integrated bypass valve
- IBT = Heat exchanger with integrated thermo-bypass valve
- AITF = Thermostat (fixed)

For all possible accessories, like vibration absorber, air filter grid or air filter mat please refer to brochure “Accessories for air coolers”.

Dimensions

AC-LN 1

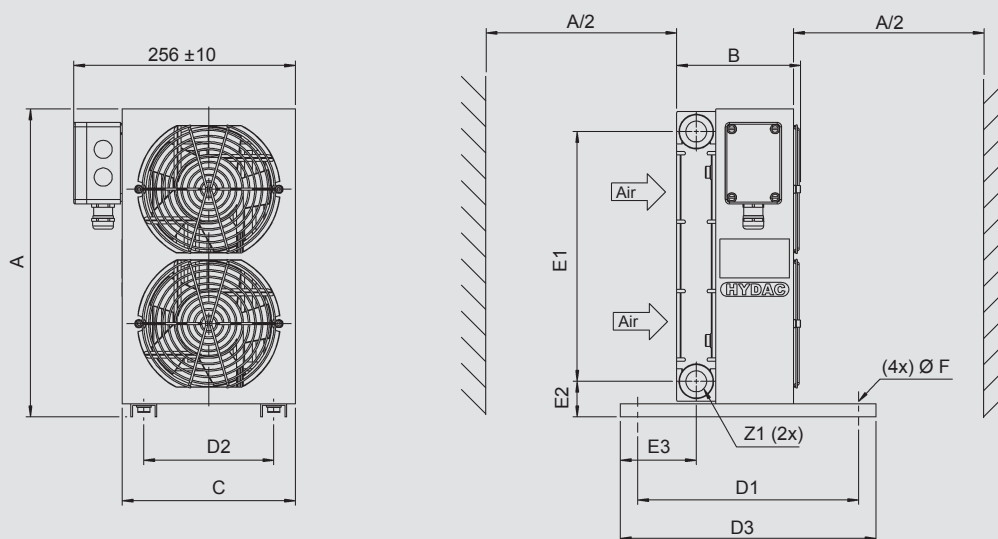

AC-LN 2-6

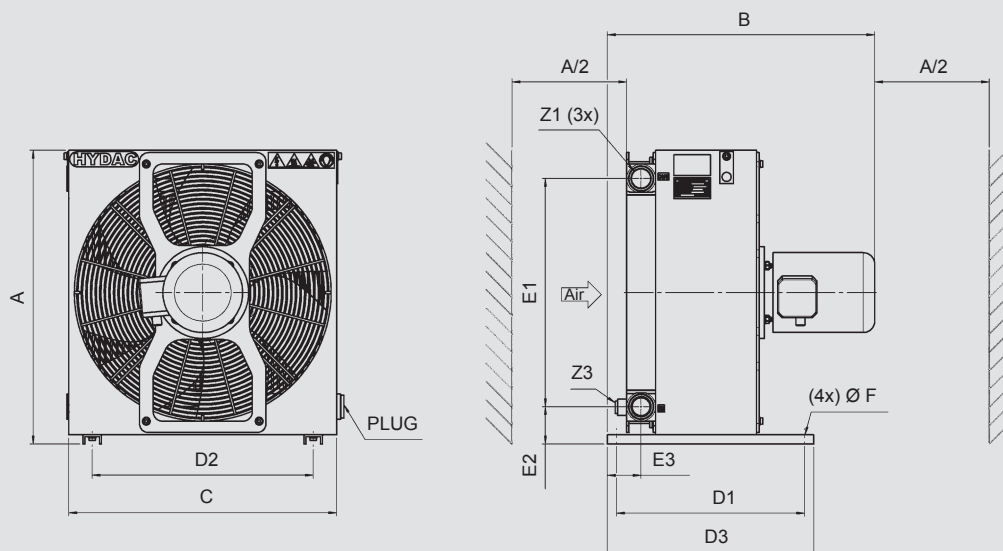

	A ±10	B ±25	C ±10	D1 ±2	D2 ±2	D3 ±2	E1 ±5	E2 ±5	E3 ±5	F Ø Slot	Z1	Z3
AC-LN1H	355	143	200	255	150	295	288	41	88	9	G3/4"	-
AC-LN2H	355	401	330	255	160	295	289	41	58	9	G3/4"	-
AC-LN2S	355	396	330	255	160	295	289	41	58	9	G3/4"	-
AC-LN3H	455	438	380	255	290	295	388	41	58	9	G3/4"	-
AC-LN3S	455	404	380	255	290	295	388	41	58	9	G3/4"	-
AC-LN4L	520	517	485	410	425	450	439	51	104	9x20	G1"	-
AC-LN4S	520	517	485	410	425	450	439	51	104	9x20	G1"	-
AC-LN5L	562	547	542	410	482	450	439	72	94	9x20	G1"	-
AC-LN5S	562	563	542	410	482	450	439	72	94	9x20	G1"	-
AC-LN6L	640	567	584	410	482	450	497	82	74	9x20	G1 1/4"	M22x1.5
AC-LN6S	640	583	584	410	482	450	497	82	74	9x20	G1 1/4"	M22x1.5

AC-LN 7

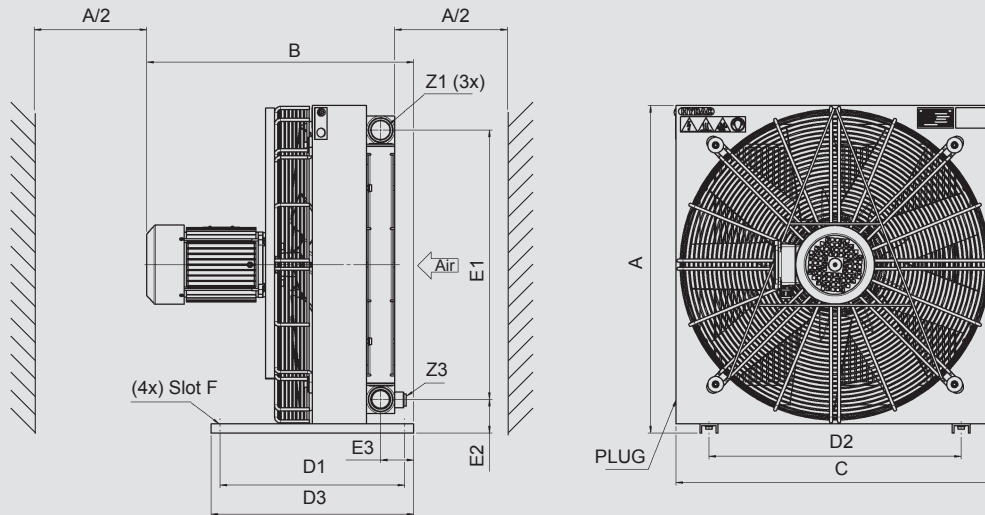

	A ±10	B ±25	C ±10	D1 ±2	D2 ±2	D3 ±2	E1 ±5	E2 ±5	E3 ±5	F Ø Slot	Z1	Z3
AC-LN7L	726	593	706	410	560	450	597	75	74	9x20	G1 1/4"	M22x1.5
AC-LN7S	726	613	706	410	560	450	597	75	74	9x20	G1 1/4"	M22x1.5

ACA-LN 2-6

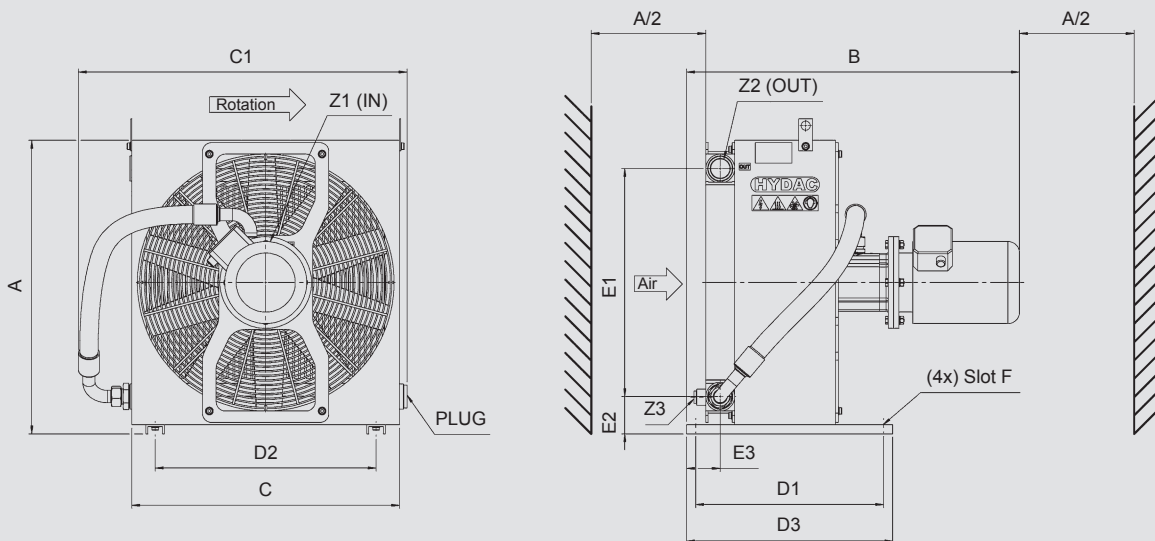

	A ±10	B ±30	C ±10	C1 ±25	D1 ±2	D2 ±2	D3 ±2	E1 ±5	E2 ±5	E3 ±5	F Ø Slot	Z1 (IN)	Z2 (3x)	Z3
ACA-LN2S	355	567	330	414	370	160	410	289	41	58	9	G 1"	G 3/4"	-
ACA-LN2H	355	596	330	414	370	160	410	289	41	58	9	G 1"	G 3/4"	-
ACA-LN3S	455	620	380	462	370	290	410	388	41	58	9	G 1"	G 3/4"	-
ACA-LN3H	455	620	380	462	370	290	410	388	41	58	9	G 1"	G 3/4"	-
ACA-LN4L	520	697	485	574	410	425	450	439	51	104	9x20	G1 1/4"	G1"	-
ACA-LN4S	520	699	485	574	410	425	450	439	51	104	9x20	G1 1/4"	G1"	-
ACA-LN5L	562	707	542	641	410	482	450	439	71.5	94	9x20	G1 1/4"	G1"	-
ACA-LN5S	562	709	542	641	410	482	450	439	71.5	94	9x20	G1 1/4"	G1"	-
ACA-LN6L	640	727	584	717	410	482	450	497	81.5	74	9x20	G1 1/4"	G1 1/4"	M22x1.5
ACA-LN6S	640	729	584	717	410	482	450	497	81.5	74	9x20	G1 1/4"	G1 1/4"	M22x1.5

ACA-LN 7

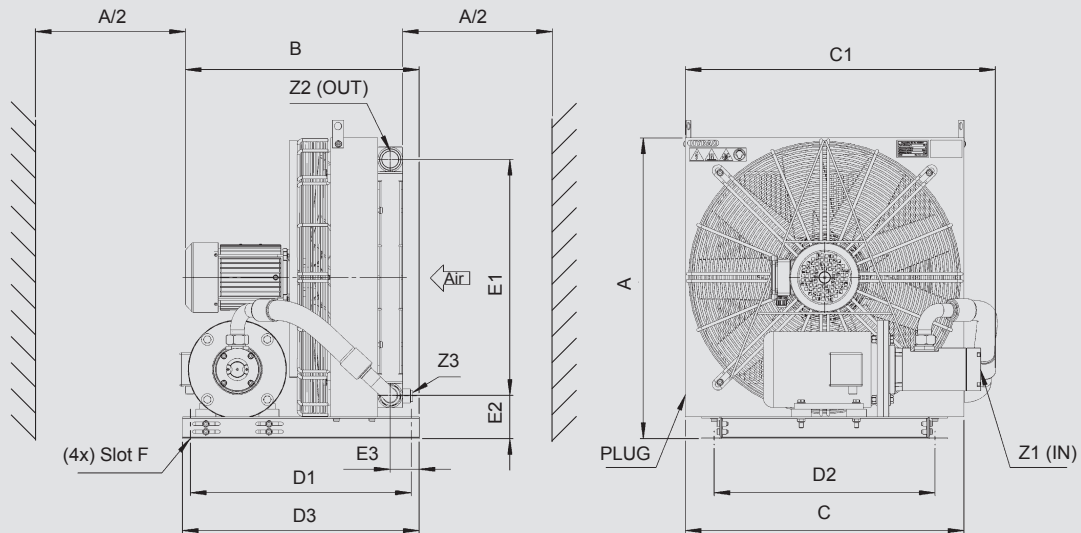

	A ±10	B ±30	C ±10	C1 ±25	D1 ±2	D2 ±2	D3 ±2	E1 ±5	E2 ±5	E3 ±5	F Ø Slot	Z1 (IN)	Z2 (3x)	Z3
ACA-LN7L	736	593	706	775	560 ¹⁾	560	600 ¹⁾	600	83	74	9x20	G 2"	G1 1/4"	M22x1.5
ACA-LN7S	736	607	706	775	560 ¹⁾	560	600 ¹⁾	600	83	74	9x20	G 2"	G1 1/4"	M22x1.5

¹⁾ Version with pump displacement 69 [cm³/U]: D1 = 830, D3 = 870

ACAF-LN 2-6

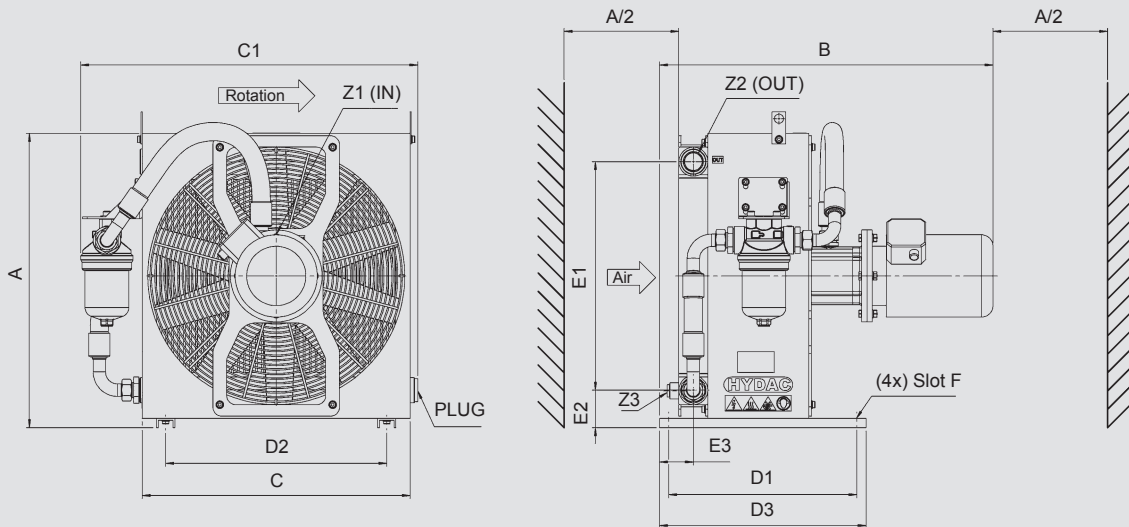

	A ±10	B ±30	C ±10	C1 ±25	D1 ±2	D2 ±2	D3 ±2	E1 ±5	E2 ±5	E3 ±5	F Ø Slot	Z1 (IN)	Z2 (3x)	Z3
ACAF-LN2S	355	567	330	467	370	160	410	289	41	58	9	G 1"	G 3/4"	-
ACAF-LN2H	355	596	330	467	370	160	410	289	41	58	9	G 1"	G 3/4"	-
ACAF-LN3S	455	620	380	517	370	290	410	388	41	58	9	G 1"	G 3/4"	-
ACAF-LN3H	455	596	380	517	370	290	410	388	41	58	9	G 1"	G 3/4"	-
ACAF-LN4L	520	697	485	619	410	425	450	439	51	104	9x20	G1 1/4"	G1"	-
ACAF-LN4S	520	699	485	619	410	425	450	439	51	104	9x20	G1 1/4"	G1"	-
ACAF-LN5L	562	707	542	676	410	482	450	439	71.5	94	9x20	G1 1/4"	G1"	-
ACAF-LN5S	562	709	542	676	410	482	450	439	71.5	94	9x20	G1 1/4"	G1"	-
ACAF-LN6L	640	727	584	734	410	482	450	497	81.5	74	9x20	G1 1/4"	G1 1/4"	M22x1.5
ACAF-LN6S	640	729	584	734	410	482	450	497	81.5	74	9x20	G1 1/4"	G1 1/4"	M22x1.5

ACAF-LN 7

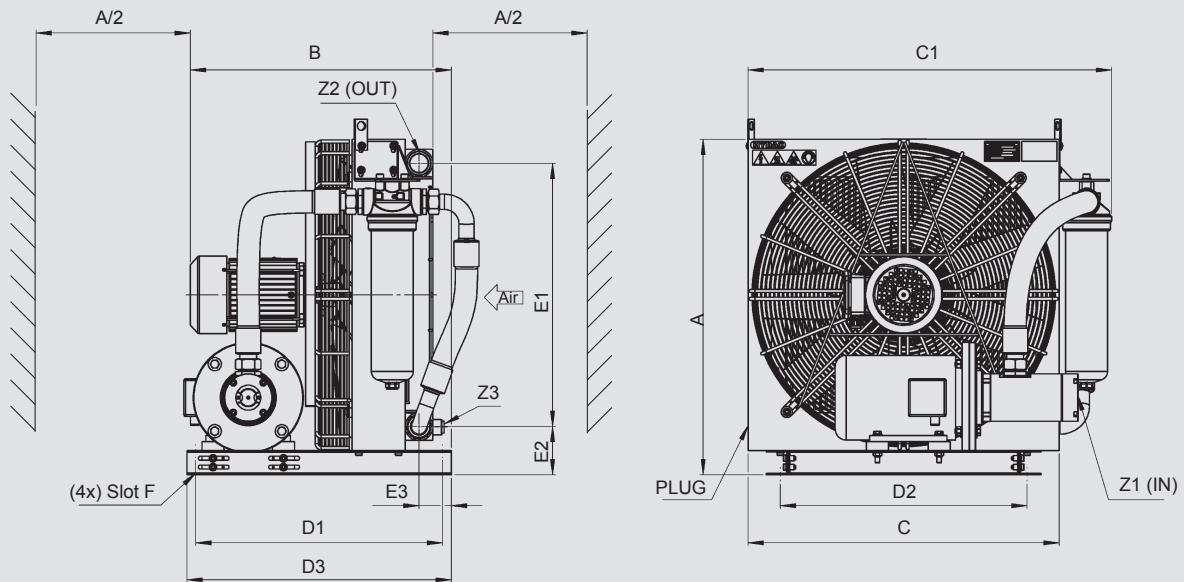

	A ±10	B ±30	C ±10	C1 ±25	D1 ±2	D2 ±2	D3 ±2	E1 ±5	E2 ±5	E3 ±5	F Ø Slot	Z1 (IN)	Z2 (3x)	Z3
ACAF-LN7L	736	593	706	775	560 ¹⁾	560	600 ¹⁾	600	83	74	9x20	G 2"	G1 1/4"	M22x1.5
ACAF-LN7S	736	607	706	775	560 ¹⁾	560	600 ¹⁾	600	83	74	9x20	G 2"	G1 1/4"	M22x1.5

¹⁾ Version with pump displacement 69 [cm³/U]: D1 = 830, D3 = 870

Note:

We recommend maintaining a minimum distance to ensure an unimpeded air inlet and air outlet. This is half the height of the cooling element (A/2). Anything below the minimum distance can influence the cooling capacity and the noise emissions.

Note

The information in this brochure relates to the operating conditions and applications described. For applications and operating conditions not described, please contact the relevant technical department. Subject to technical modifications.

HYDAC

HYDAC COOLING GMBH

INTERNATIONAL

Industriegebiet
66280 Sulzbach/Saar
Germany

Tel.: +49 6897 509-01
Fax: +49 6897 509-454

E-mail: cooling@hydac.com
Internet: www.hydac.com

HYDAC AG
Mezzovico Branch

Via Sceresca, Zona Industriale 3
6805 Mezzovico
Switzerland

Tel.: +41 91 9355-700
Fax: +41 91 9355-701

E-mail: info@hydac.ch
Internet: www.hydac.com



Air Cooler Industry

AC-LN 8-14 / ACA-LN 8-11 / ACAF-LN 8-11

Symbol

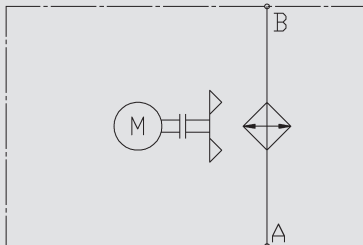

General

The AC-LN 8-14 air cooler series can be used in all areas where either oil or water-glycol is to be cooled with air. The coolers with an axial fan can be used in the return line as well as in the bypass flow.

The wide range of accessories and optional versions mean that the coolers can be adapted flexibly to various applications.

Product Features

The air flow of the cooler has been optimized by the use of a more efficient axial fan and a variety of housing modifications. As a result, the AC-LN series 8-14 is especially efficient and quiet.

The cooler can also be used in the bypass flow by attaching a boost pump. An additional filter enables continuous filtration of the medium; the cooler can then be connected as required.

- Large product range
- Large cooling performance range
- Modular design

Operation Data

Fluids	Oils (mineral oils, synthetic oils, high viscosity oils, biological oils, phosphate ester) Water-glycol (cooling fluid) HFC pressure fluids
Viscosity	AC-LN: 2.000 mm ² /s (standard) ACA-LN/ACAF-LN: see technical data
Temperature range	Minimum / maximum ambient temperature: -20 °C to +40 °C (standard) Maximum temperature of the medium: +130 °C Please contact the technical sales department in the event of deviating temperatures. Notice! Fan switching frequency at max. fan speed (max. volume of air) must be avoided when operating a cooler at which the temperature difference between the medium inlet at the cooler and the ambient temperature can be greater than 50°C. Quick changes in the temperature of the cooling element material can lead to a significant reduction in service life or to direct damage of the cooling element due to thermal shock. Please contact the technical sales department to receive information about controlled fan drives.
Pressure resistance of the cooling element	Dynamic operating pressure: 16 bar Static operating pressure: 21 bar
Fan	Axial fan in suction version (standard) Axial fan in blowing version on request (note: with blowing version approx. 10 % less cooling capacity)
Motor	Three-phase motor Efficiency class IE2 Protection class IP55 Insulation class F Other versions on request
ErP	The fan unit of the AC-LN corresponds to the minimum efficiency levels specified in the Ecodesign directive or ErP directive (Energy-related Products) 2009/125/EC.
Pump (only ACA-LN/ACAF-LN)	Screw pump with separate motor Pump motor speed: 3,000 rpm Negative suction pressure of the pump: max. -0.4 bar
Noise levels	See technical data AC-LN and ACA-LN/ACAF-LN The noise levels are only reference values as the acoustic properties of a room, connections and reflection have an effect on the noise level.
Accessories	Integrated pressure bypass valve (IBP) or integrated thermal pressure bypass valve (IBT) (cannot be retrofitted, also see options) Thermostats Air filter grid or air filter mat Vibration damper

Application Field

Systems with high cooling requirements, such as:

- Hydraulic systems
- Lubrication systems
- Gears
- Motors
- Generators
- Converters
- Machine tools

Options

Integrated pressure bypass valve (IBP) / Integrated thermal pressure bypass valve (IBT)

The bypass channel is integrated in the cooling element. If a particular pressure is exceeded, the IBP opens the bypass channel, thereby protecting the cooling element from too high a pressure. Furthermore, the IBT only opens the cooling element path once a particular temperature has been reached.

Large coolers

Coolers with a higher cooling capacity than standard are also available as special versions.

Speed control: AC-LN MI

The integrated frequency converter enables stepless speed control dependent on the oil temperature in the cooling element.

ATEX

The AC-LN (without pump and filter) is also available for operation in gas and dust explosive areas. The ATEX certification applies for a frequency of 50 Hz and 60 Hz.

Marine

The MAR version is for aggressive ambient conditions, such as industrial atmospheres, high humidity or high salt content, which place great demands on the corrosion resistance and robustness of the materials used.

Cold Climate / Hot Climate

Use in extreme ambient conditions:
Cold Climate to $-40\text{ }^{\circ}\text{C}$,
Hot Climate to $+60\text{ }^{\circ}\text{C}$

The various versions can also be combined. Our technical sales department will be happy to assist you further.

Design

AC-LN 8-9-10-11

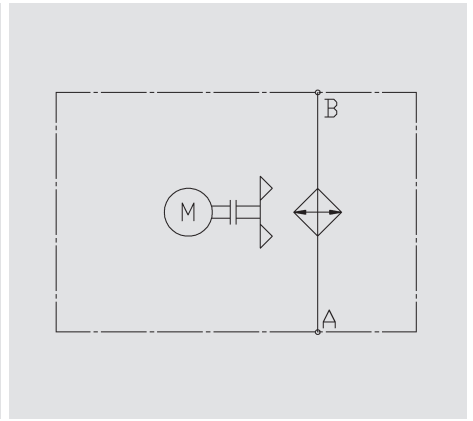
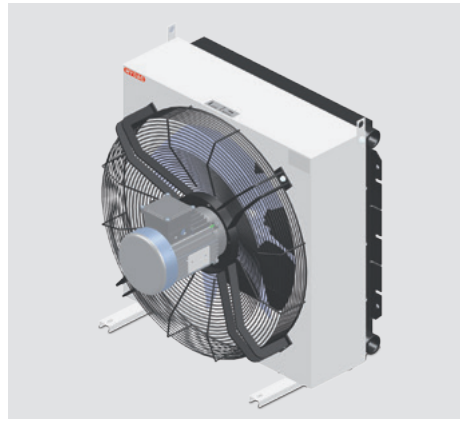

- 1 Motor
- 2 Axial fan
- 3 Fan housing
- 4 Heat exchanger

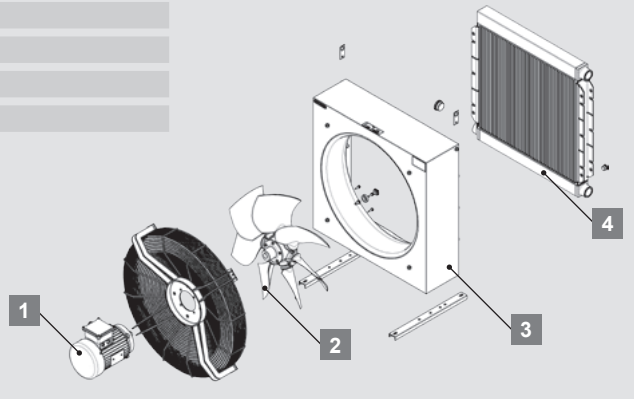

AC-LN 12-14

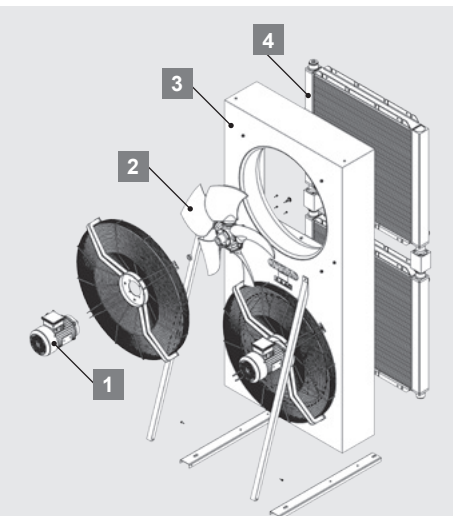
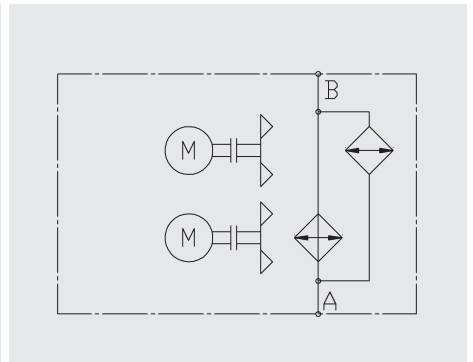

- 1 Motor
- 2 Axial fan
- 3 Fan housing
- 4 Heat exchanger

Design

ACA-LN8-9-10-11

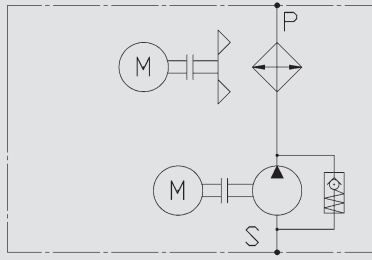
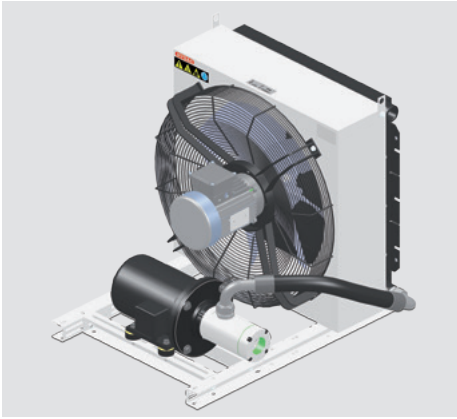

- 1 Drive motor
- 2 Axial fan
- 3 Low-noise screw pump
- 4 Fan housing
- 5 Heat exchanger

With external motor-pump assembly attached onto the base frame.

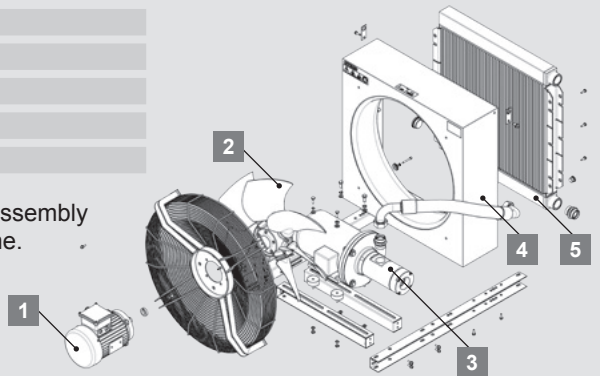

ACAF-LN8-9-10-11

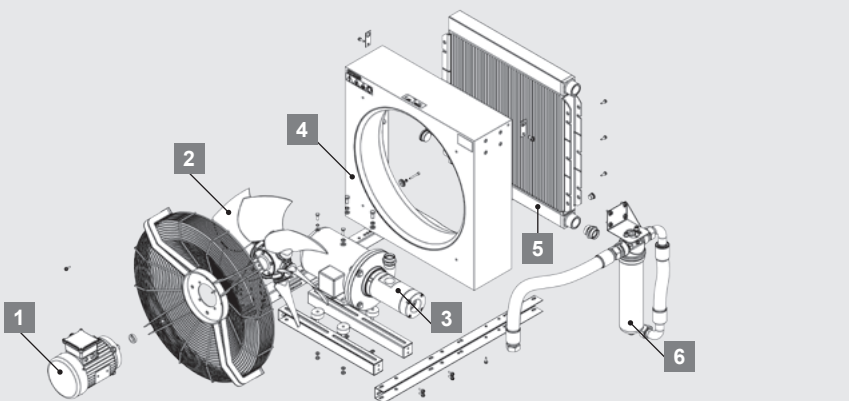
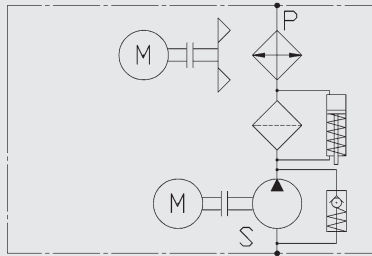
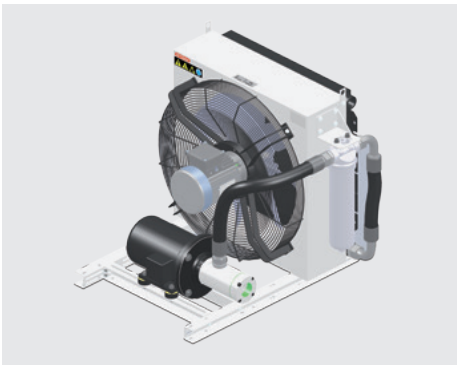

- 1 Drive motor
- 2 Axial fan
- 3 Low-noise screw pump
- 4 Fan housing
- 5 Heat exchanger
- 6 Filter

With external motor-pump assembly attached onto the base frame.

The filter is equipped with a visual clogging indicator as standard.

Technical Data

AC-LN

Type of cooler	P/N	Fluid [-] ¹⁾	Fluid flow [l/min] ²⁾	Air flow [m ³ /h]	Fan motor: Poles / size / flange	Fan motor: Power / current absorption [kW / A] ³⁾	Noise level (at 1 m distance, 50 Hz) [dB(A)]	Volume [l] ⁴⁾	Weight [kg] ⁵⁾
----------------	-----	-------------------------	----------------------------------	------------------------------	-------------------------------------	---	---	--------------------------	---------------------------

VERSION B: 50 Hz

AC-LN8L	3686293	F	350	5,800	6/90/B14	0.75 / 2.0	68	6	72
AC-LN8S	3686305	F	350	8,700	4/90/B14	1.5 / 3.3	79	6	72
AC-LN9L	3686306	F	350	7,500	6/90/B14	0.75 / 2.0	67	11	100
AC-LN9S	3770160	F	350	10,900	4/90/B14	1.5 / 3.3	80	11	100
AC-LN10L	3686307	F	540	11,300	6/90/B14	1.1 / 2.65	71	14	129
AC-LN10S	3773324	F	540	16,500	4/100/B14	3.0 / 6.0	77	14	129
AC-LN11L	3686308	F	540	17,400	6/112/B14	2.2 / 4.6	75	18	170
AC-LN11S	3773334	F	540	23,600	4/112/B14	4.0 / 7.7	81	18	170
AC-LN12L	3704261	F	840	22,600	6/90/B14	1.1 / 2.65	74	28	290
AC-LN12S	3773864	F	840	33,000	4/100/B14	3.0 / 6.0	80	28	290
AC-LN14L	3704260	F	840	34,800	6/112/B14	2.2 / 4.6	78	35	320
AC-LN14S	3773890	F	840	47,200	4/112/B14	4.0 / 7.7	84	35	320

VERSION C: 60 Hz

AC-LN8L	3763003	F	350	6,150	6/90/B14	0.9 / 2.0	71	6	72
AC-LN8S	3763036	F	350	8,700	4/90/B14	1.8 / 3.3	83	6	72
AC-LN9L	3763004	F	350	7,500	6/90/B14	0.9 / 2.0	70	11	100
AC-LN9S	3772994	F	350	10,900	4/90/B14	1.8 / 3.3	83	11	100
AC-LN10L	3733086	F	540	12,000	6/90/B14	1.3 / 2.7	74	14	129
AC-LN10S	3774291	F	540	16,400	4/100/B14	3.6 / 7.2	80	14	129
AC-LN11L	3763035	F	540	18,300	6/112/B14	2.6 / 4.6	78	18	170
AC-LN11S	3774293	F	540	23,600	4/112/B14	4.8 / 8.0	84	18	170
AC-LN12L	3765763	F	840	24,000	6/90/B14	1.3 / 2.7	77	28	290
AC-LN12S	3774304	F	840	32,800	4/100/B14	3.6 / 7.2	83	28	290
AC-LN14L	3765740	F	840	36,600	6/112/B14	2.6 / 4.6	81	35	320
AC-LN14S	3774312	F	840	47,200	4/112/B14	4.8 / 8.0	87	35	320

¹⁾ Medium: F = mineral oil or water-glycol, M = mineral oil

²⁾ Max. flow rate

³⁾ Current requirement: B version at 400 V – 50 Hz / C version at 480 V – 60 Hz, AC-LN 12-14: each motor

⁴⁾ Fluid in cooling element

⁵⁾ Unfilled

Technical Data

ACA-LN / ACAF-LN

Type of cooler	Fluid [-] ¹⁾	Fluid flow [l/min]	Air flow [m³/h]	Pump displacement [cm³/U]	Max. viscosity [mm²/s] continuous working ²⁾	Pump motor: power / current absorption [kW/A] ³⁾		Fan motor: Poles / size / flange	Fan motor: power / current absorption [kW / A] ³⁾	Filter size [-]	Noise level (at 1 m distance, 50 Hz) [dB(A)]	Volume [l] ⁴⁾	Weight [kg] ⁵⁾
						40/58	69						

VERSION B: 50 Hz

ACA-LN8L	M	100/150/180	5,800	40/58/69	320/130/240	3.0 / 6.7	5.5 / 10.4	6/90/B14	0.75 / 2.0	-	68	6	102
ACA-LN8S	M	100/150/180	8,700	40/58/69	320/130/240	3.0 / 6.7	5.5 / 10.4	4/90/B14	1.5 / 3.3	-	79	6	102
ACAF-LN8L	M	100/150/180	5,800	40/58/69	320/130/240	3.0 / 6.7	5.5 / 10.4	6/90/B14	0.75 / 2.0	LPF280	68	6	110
ACAF-LN8S	M	100/150/180	8,700	40/58/69	320/130/240	3.0 / 6.7	5.5 / 10.4	4/90/B14	1.5 / 3.3	LPF280	79	6	110
ACA-LN9L	M	100/150/180	7,500	40/58/69	320/130/240	3.0 / 6.7	5.5 / 10.4	6/90/B14	0.75 / 2.0	-	67	11	132
ACA-LN9S	M	100/150/180	10,900	40/58/69	320/130/240	3.0 / 6.7	5.5 / 10.4	4/90/B14	1.5 / 3.3	-	80	11	132
ACAF-LN9L	M	100/150/180	7,500	40/58/69	320/130/240	3.0 / 6.7	5.5 / 10.4	6/90/B14	0.75 / 2.0	LPF280	67	11	140
ACAF-LN9S	M	100/150/180	10,900	40/58/69	320/130/240	3.0 / 6.7	5.5 / 10.4	4/90/B14	1.5 / 3.3	LPF280	80	11	140
ACA-LN10L	M	100/150/180	11,300	40/58/69	320/130/240	3.0 / 6.7	5.5 / 10.4	6/90/B14	1.1 / 2.65	-	71	14	172
ACA-LN10S	M	100/150/180	16,500	40/58/69	320/130/240	3.0 / 6.7	5.5 / 10.4	4/100/B14	3.0 / 6.0	-	77	14	172
ACAF-LN10L	M	100/150/180	11,300	40/58/69	320/130/240	3.0 / 6.7	5.5 / 10.4	6/90/B14	1.1 / 2.65	LPF280	71	14	180
ACAF-LN10S	M	100/150/180	16,500	40/58/69	320/130/240	3.0 / 6.7	5.5 / 10.4	4/100/B14	3.0 / 6.0	LPF280	77	14	180
ACA-LN11L	M	100/150/180	17,400	40/58/69	320/130/240	3.0 / 6.7	5.5 / 10.4	6/112/B14	2.2 / 4.6	-	75	18	212
ACA-LN11S	M	100/150/180	23,600	40/58/69	320/130/240	3.0 / 6.7	5.5 / 10.4	4/112/B14	4.0 / 7.7	-	81	18	212
ACAF-LN11L	M	100/150/180	17,400	40/58/69	320/130/240	3.0 / 6.7	5.5 / 10.4	6/112/B14	2.2 / 4.6	LPF280	75	18	220
ACAF-LN11S	M	100/150/180	23,600	40/58/69	320/130/240	3.0 / 6.7	5.5 / 10.4	4/112/B14	4.0 / 7.7	LPF280	81	18	220

VERSION C: 60 Hz

ACA-LN8L	M	120/180/215	6,150	40/58/69	320/130/240	3.0 / 6.7	5.5 / 10.4	6/90/B14	0.9 / 2.0	-	71	6	102
ACA-LN8S	M	120/180/215	8,700	40/58/69	320/130/240	3.0 / 6.7	5.5 / 10.4	4/90/B14	1.8 / 3.3	-	83	6	102
ACAF-LN8L	M	120/180/215	6,150	40/58/69	320/130/240	3.0 / 6.7	5.5 / 10.4	6/90/B14	0.9 / 2.0	LPF280	71	6	110
ACAF-LN8S	M	120/180/215	8,700	40/58/69	320/130/240	3.0 / 6.7	5.5 / 10.4	4/90/B14	1.8 / 3.3	LPF280	83	6	110
ACA-LN9L	M	120/180/215	7,500	40/58/69	320/130/240	3.0 / 6.7	5.5 / 10.4	6/90/B14	0.9 / 2.0	-	70	11	132
ACA-LN9S	M	120/180/215	10,900	40/58/69	320/130/240	3.0 / 6.7	5.5 / 10.4	4/90/B14	1.8 / 3.3	-	83	11	132
ACAF-LN9L	M	120/180/215	7,500	40/58/69	320/130/240	3.0 / 6.7	5.5 / 10.4	6/90/B14	0.9 / 2.0	LPF280	70	11	140
ACAF-LN9S	M	120/180/215	10,900	40/58/69	320/130/240	3.0 / 6.7	5.5 / 10.4	4/90/B14	1.8 / 3.3	LPF280	83	11	140
ACA-LN10L	M	120/180/215	12,000	40/58/69	320/130/240	3.0 / 6.7	5.5 / 10.4	6/90/B14	1.3 / 2.7	-	74	14	172
ACA-LN10S	M	120/180/215	16,400	40/58/69	320/130/240	3.0 / 6.7	5.5 / 10.4	4/100/B14	3.6 / 7.2	-	80	14	172
ACAF-LN10L	M	120/180/215	12,000	40/58/69	320/130/240	3.0 / 6.7	5.5 / 10.4	6/90/B14	1.3 / 2.7	LPF280	74	14	180
ACAF-LN10S	M	120/180/215	16,400	40/58/69	320/130/240	3.0 / 6.7	5.5 / 10.4	4/100/B14	3.6 / 7.2	LPF280	80	14	180
ACA-LN11L	M	120/180/215	18,300	40/58/69	320/130/240	3.0 / 6.7	5.5 / 10.4	6/112/B14	2.6 / 4.6	-	78	18	212
ACA-LN11S	M	120/180/215	23,600	40/58/69	320/130/240	3.0 / 6.7	5.5 / 10.4	4/112/B14	4.8 / 8.0	-	84	18	212
ACAF-LN11L	M	120/180/215	18,300	40/58/69	320/130/240	3.0 / 6.7	5.5 / 10.4	6/112/B14	2.6 / 4.6	LPF280	78	18	220
ACAF-LN11S	M	120/180/215	23,600	40/58/69	320/130/240	3.0 / 6.7	5.5 / 10.4	4/112/B14	4.8 / 8.0	LPF280	84	18	220

¹⁾ Medium: F = mineral oil or water-glycol, M = mineral oil

²⁾ Depends on pump displacement

³⁾ Current requirement: B version at 400 V – 50 Hz / C version at 480 V – 60 Hz

⁴⁾ Fluid in cooling element

⁵⁾ Unfilled

Cooling in bypass flow: ACA-LN / ACAF-LN

The ACA-LN with integrated boost pump is a complete bypass flow cooling system; the ACAF-LN is equipped with a high-quality HYDAC filter for additional filtration.

Advantages:

- Stable cooling and filtration (independent of the cycle times of the system)
- Continuous filtration is possible, cooling as required
- Avoidance of pressure surges in the cooling element
- Design of the cooler is in accordance with the cooling capacity required (not according to the maximum possible return flow volume)

Cooling Capacity and Pressure Difference Δp

Mineral oil

AC-LN / ACA-LN / ACAF-LN

50 Hz / 60 Hz

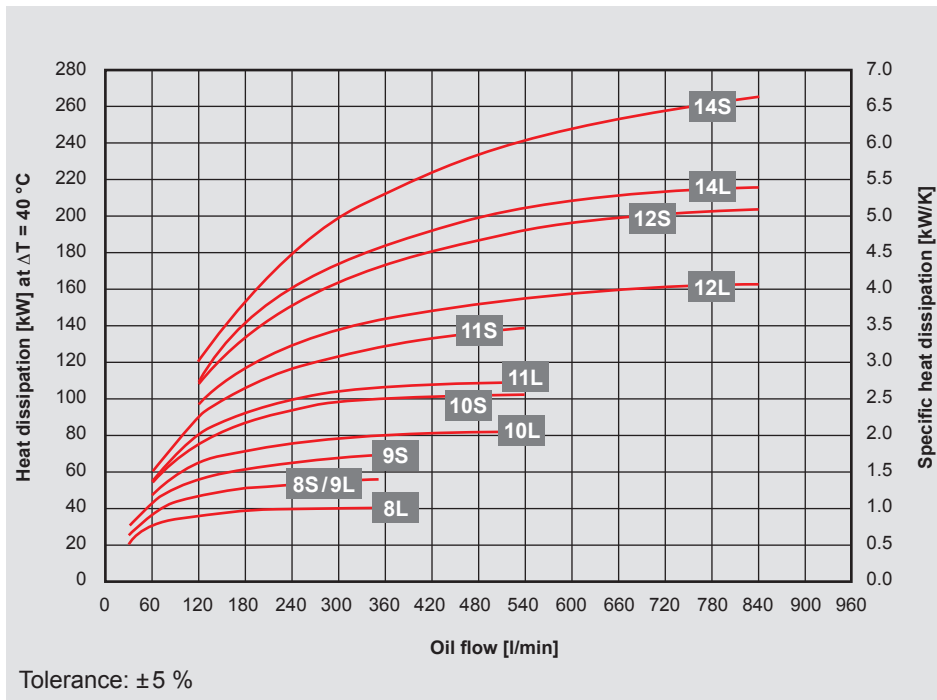

Cooling capacity:

Dependent on the oil flow rate and the temperature difference ΔT between oil inlet and air inlet.

Note:

The values are measured at $\Delta T = 40^\circ\text{C}$. For smaller ΔT values, the values can change. You can also use our cooler calculation software for designing. Please contact our technical sales department.

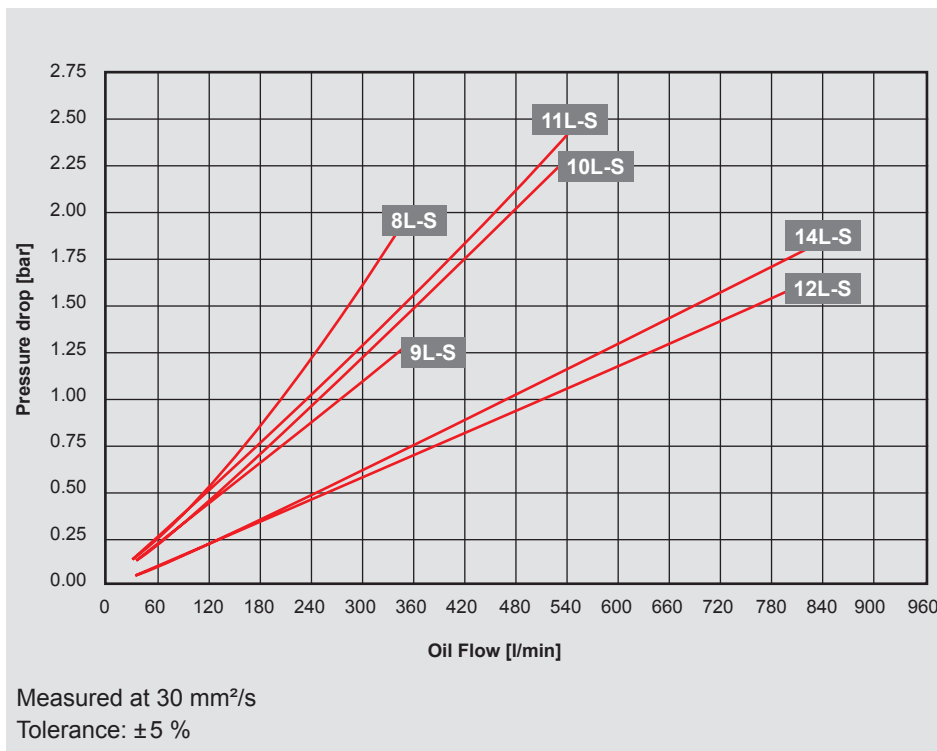

Pressure difference Δp

For other viscosities, the pressure loss must be multiplied by the conversion factor K:

Viscosity (mm^2/s)	10	15	22	30	46	68	100	150
Factor K	0.35	0.5	0.75	1	1.4	1.9	2.5	3.5

Cooling Capacity and Pressure Difference Δp

Water-glycol (60/40)

AC-LN

50 Hz / 60 Hz

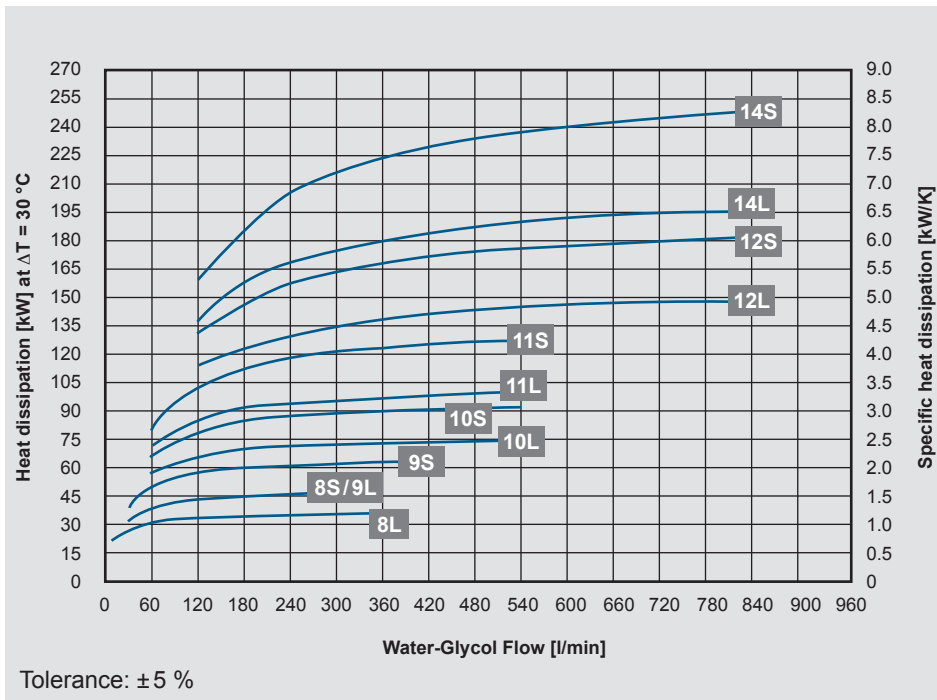

Cooling capacity:

Dependant on the water-glycol flow rate and the temperature difference ΔT between w/g inlet and air inlet.

Note:

The values are measured at $\Delta T = 30\text{ °C}$. For smaller ΔT values, the values can change. You can also use our cooler calculation software for designing. Please contact our technical sales department.

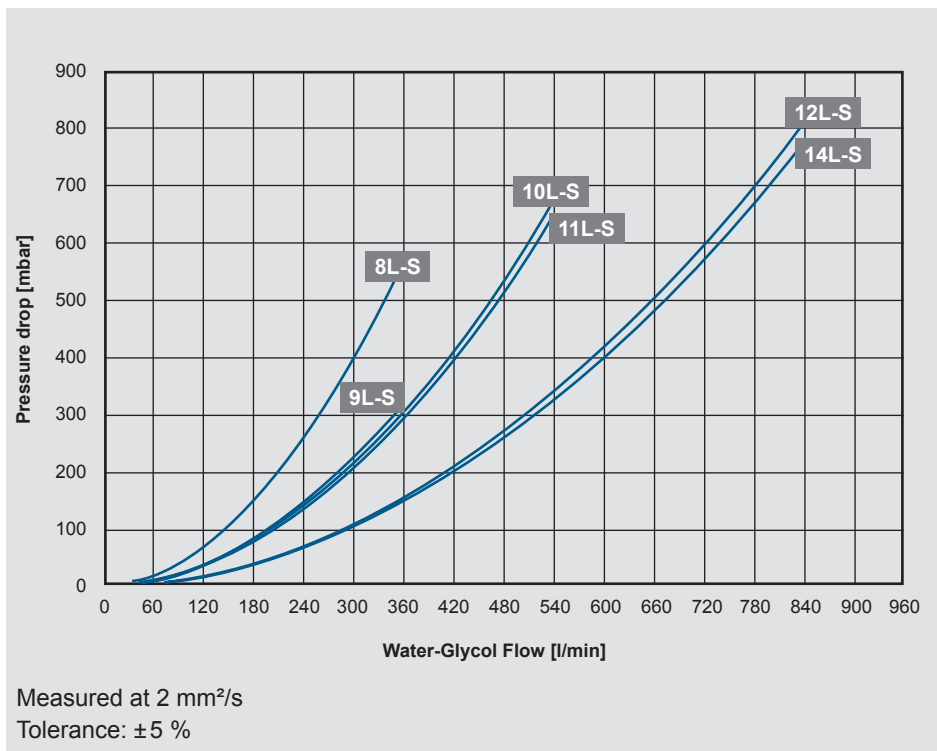

Pressure difference Δp

Model Type

ACAF-LN 8S - 40 - 1.0 - B - M - B - LPF280 - 10 - 1 - IBT

Cooler type

- AC-LN = Air cooler (oil / water-glycol mix)
- ACA-LN = Air cooler (oil) with integrated pump
- ACAF-LN = Air cooler (oil) with integrated pump and filter

Size / motor speed

- 8-14 = Size
- L = 6 poles (1,000 rpm)
- S = 4 poles (1,500 rpm)

Displacement cm³/rev

40/58/69 (only ACA-LN/ACAF-LN 8-11)

Revision

Clogging indicators (only ACAF-LN)

- A = Without clogging indicator
- B = With visual indicator (Standard)
- D = With electrical and optical indicator (24 V)

Fluids

- F = Mineral oil or water glycol mix (AC-LN)
- M = Mineral oil (ACA-LN and ACAF-LN)

Motor voltage

Standard voltages and frequencies for 3 phase motor

- B = 230/400 V – 50 Hz
 - C = 265/460 V – 60 Hz
 - A = Special version 230/400 V – 50 Hz / 265/460 V – 60 Hz
(tolerance voltage ± 10 %)
- Other voltages on request

Size of filter (only ACAF-LN)

ACAF-LN8-11 = LPF280

Filtration rating in micron (only ACAF-LN)

- 5 = 5 µm Betamicron®-4-N (5 BN4HC)
- 10 = 10 µm Betamicron®-4-N (10 BN4HC) (standard)
- 20 = 20 µm Betamicron®-4-N (20 BN4HC)

Color

- 1 = RAL 9002 (standard)
- Other colors on request.

Accessories

- IBP = Heat exchanger with integrated bypass valve
 - IBT = Heat exchanger with integrated thermo-bypass valve
 - AITF = Thermostat (fixed)
- For all possible accessories, like vibration absorber, air filter grid or air filter mat please refer to brochure Accessories for air coolers.

Dimensions

AC-LN 8-9-10-11

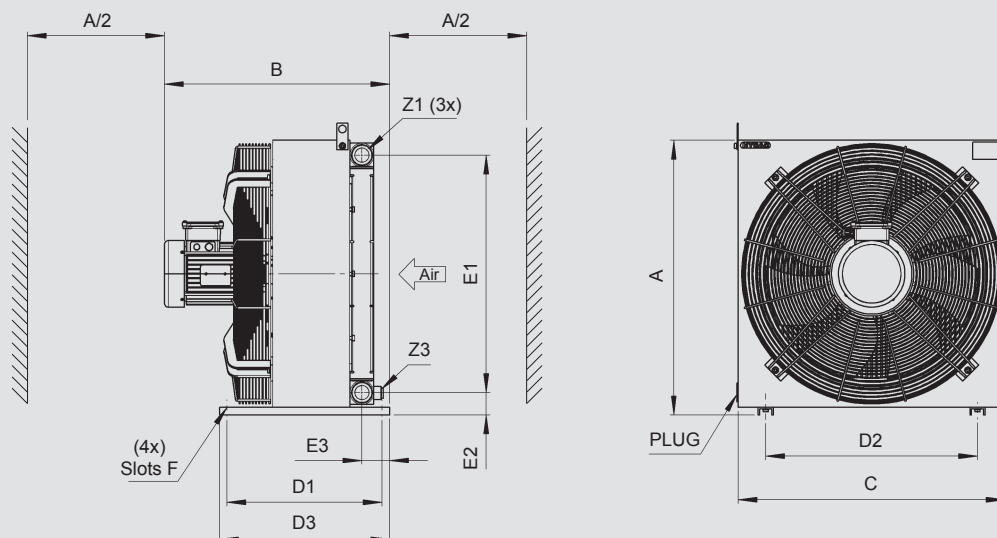

AC-LN 12-14

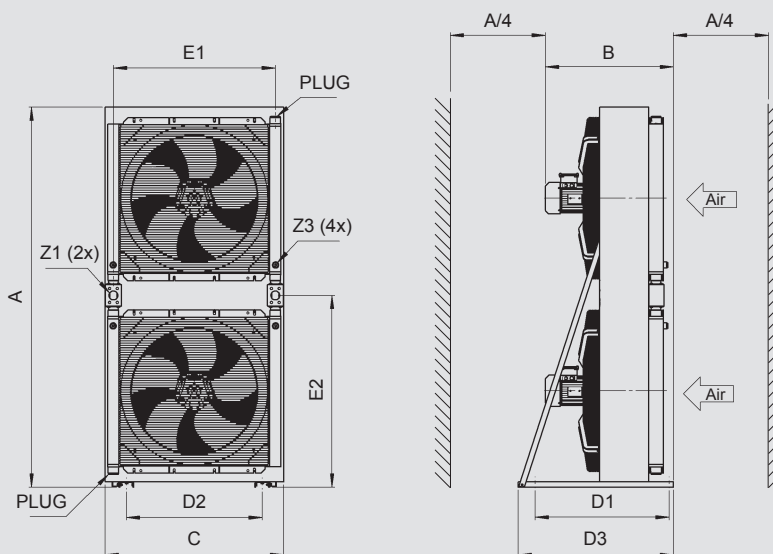

	A ±10	B ±25	C ±10	D1 ±2	D2 ±2	D3 ±2	E1 ±5	E2 ±5	E3 ±5	F ø Slots	Z1	Z3
AC-LN8 L	725	596	705	410	560	450	627	58	74	9x20	G1¼"	M22x1.5
AC-LN8 S	725	626	705	410	560	450	627	58	74	9x20	G1¼"	M22x1.5
AC-LN9 L	880	750	790	750	700	790	757	76.5	148	12	G1½"	M22x1.5
AC-LN9 S	880	780	790	750	700	790	757	76.5	148	12	G1½"	M22x1.5
AC-LN10 L	1,030	766	930	750	700	790	907	76.5	147	12	G1½"	M22x1.5
AC-LN10 S	1,030	787	930	750	700	790	907	76.5	147	12	G1½"	M22x1.5
AC-LN11 L	1,180	811	1,050	750	700	790	1,057	76.5	147	12	G1½"	M22x1.5
AC-LN11 S	1,180	810	1,050	750	700	790	1,057	76.5	147	12	G1½"	M22x1.5
AC-LN12 L	2,130	718	1,000	750	760	870	907	1,075	-	13x30	SAE2"	M22x1.5
AC-LN12 S	2,130	738	1,000	750	760	870	907	1,075	-	13x30	SAE2"	M22x1.5
AC-LN14 L	2,297	763	1,140	750	900	870	1,057	1,166	-	13x30	SAE2"	M22x1.5
AC-LN14 S	2,297	761	1,140	750	900	870	1,057	1,166	-	13x30	SAE2"	M22x1.5

Dimensions

ACA-LN 8-9-10-11

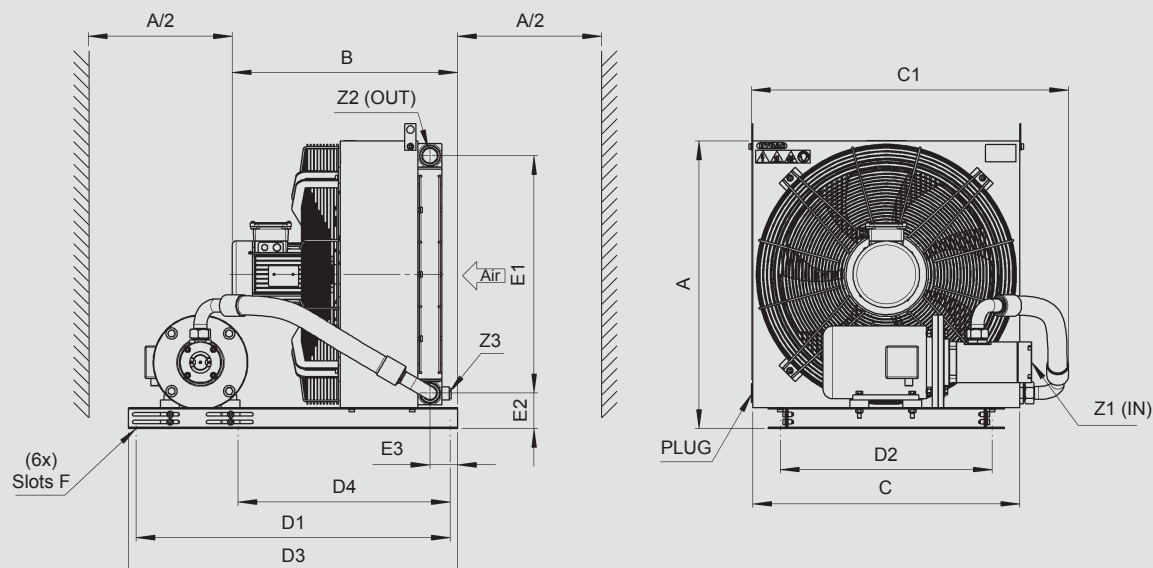

ACAF-LN 8-9-10-11

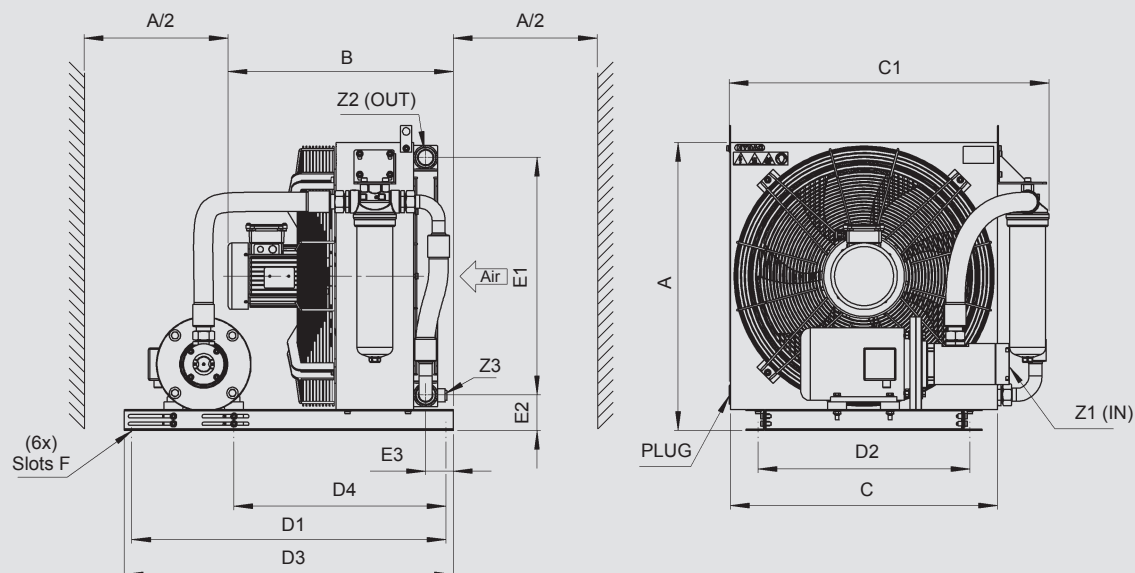

	A ±10	B ±25	C ±10	C1 ±25	D1 ±2	D2 ±2	D3 ±2	D4 ±2	E1 ±5	E2 ±5	E3 ±5	F Ø Slots	Z1 (IN)	Z2 (3x)	Z3
ACA-LN8L	760	596	705	837	830	560	870	560	627	94	74	9x20	G2"	G1 1/4"	M22x1.5
ACA-LN8S	760	626	705	837	830	560	870	560	627	94	74	9x20	G2"	G1 1/4"	M22x1.5
ACA-LN9L	905	730	790	914	830	700	870	560	757	102	128	9x20	G2"	G1 1/2"	M22x1.5
ACA-LN9S	905	760	790	914	830	700	870	560	757	102	128	9x20	G2"	G1 1/2"	M22x1.5
ACA-LN10L	1,055	746	930	1,053	830	700	870	560	907	102	127	9x20	G2"	G1 1/2"	M22x1.5
ACA-LN10S	1,055	767	930	1,053	830	700	870	560	907	102	127	9x20	G2"	G1 1/2"	M22x1.5
ACA-LN11L	1,205	791	1,050	1,164	830	700	870	560	1,057	102	127	9x20	G2"	G1 1/2"	M22x1.5
ACA-LN11S	1,205	790	1,050	1,164	830	700	870	560	1,057	102	127	9x20	G2"	G1 1/2"	M22x1.5
ACAF-LN8L	760	596	705	846	830	560	870	560	627	94	74	9x20	G2"	G1 1/4"	M22x1.5
ACAF-LN8S	760	626	705	846	830	560	870	560	627	94	74	9x20	G2"	G1 1/4"	M22x1.5
ACAF-LN9L	905	730	790	929	830	700	870	560	757	102	128	9x20	G2"	G1 1/2"	M22x1.5
ACAF-LN9S	905	760	790	929	830	700	870	560	757	102	128	9x20	G2"	G1 1/2"	M22x1.5
ACAF-LN10L	1,055	746	930	1,068	830	700	870	560	907	102	127	9x20	G2"	G1 1/2"	M22x1.5
ACAF-LN10S	1,055	767	930	1,068	830	700	780	560	907	102	127	9x20	G2"	G1 1/2"	M22x1.5
ACAF-LN11L	1,205	791	1,050	1,193	830	700	870	560	1,057	102	127	9x20	G2"	G1 1/2"	M22x1.5
ACAF-LN11S	1,205	790	1,050	1,193	830	700	870	560	1,057	102	127	9x20	G2"	G1 1/2"	M22x1.5

Note:

We recommend maintaining a minimum distance to ensure an unimpeded air inlet and air outlet. For sizes 8-11 this is half the height of the cooling element ($A/2$); for sizes 12-14 it is a quarter of the element height ($A/4$). Anything below the minimum distance can influence the cooling capacity and the noise emissions.

Note

The information in this brochure relates to the operating conditions and applications described.

For applications and operating conditions not described, please contact the relevant technical department.

Subject to technical modifications.



HYDAC COOLING GMBH

INTERNATIONAL

Industriegebiet
66280 Sulzbach/Saar
Germany

Tel.: +49 6897 509-01
Fax: +49 6897 509-454

E-mail: cooling@hydac.com
Internet: www.hydac.com

**HYDAC AG
Mezzovico Branch**

Via Sceresca, Zona Industriale 3
6805 Mezzovico
Switzerland

Tel.: +41 91 9355-700
Fax: +41 91 9355-701

E-mail: info@hydac.ch
Internet: www.hydac.com

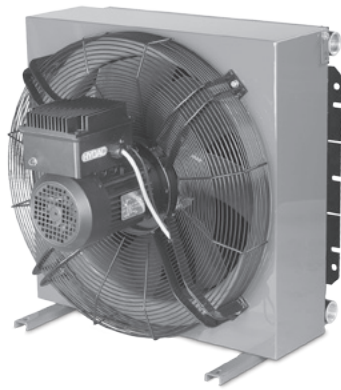

Air Cooler Industry AC-LN 8-14 MI with integrated frequency inverter

Symbol

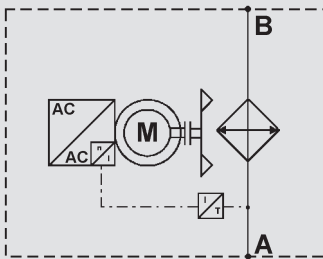

General

The AC-LN MI air cooler series can be used in all areas where either oil or water-glycol has to be cooled with air.

The integrated frequency inverter controls the fan speed depending on the fluid temperature. This way fluid temperature keep a constant level with less energy consumption and less noise.

The wide range of accessories and optional versions mean that the coolers can be adapted flexibly to various applications.

Application Field

Systems with high cooling requirements in return line and off line, such as:

- Hydraulic systems
- Lubrication systems
- Gears
- Motors
- Generators
- Converters
- Machine tools

Operation Data

Fluids	Oils (mineral oils, synthetic oils, high viscosity oils, biological oils, phosphate ester) Water-glycol (cooling fluid) HFC pressure fluids
Viscosity	AC-LN: 2,000 mm ² /s (standard)
Temperature range	Minimum / maximum ambient temperature: -20 °C to +40 °C (standard) Maximum temperature of the medium: +130 °C Please contact the technical sales department in the event of deviating temperatures.
Pressure resistance of the cooling element	Dynamic operating pressure: 16 bar Static operating pressure: 21 bar
Fan	Axial fan in suction version (standard) Axial fan in pushing version on request (note: approx. 10 % less cooling capacity)
Motoinverter	Three-phase motor Protection class IP55 Insulation class F With integrated frequency inverter Nominal power: 2.2 kW at 400 V Max. current absorption: 10 A
ErP	The fan unit of the AC-LN MI corresponds to the minimum efficiency levels specified in the Ecodesign directive or ErP directive (Energy-related Products) 2009/125/EC.
Noise levels	See technical data AC-LN MI. The average noise level could be lower than the values indicated in the table. The noise levels are only reference values as the acoustic properties of a room, connections and reflection have an effect on the noise level.
Accessories	Integrated pressure bypass valve (IBP) or integrated thermal pressure bypass valve (IBT) (cannot be retrofitted, also see options) Air filter grid or air filter mat Vibration damper

Product Features

AC-LN MI coolers use high efficiency axial fans driven by a frequency inverter. This guarantees immediate adjustment to required cooling performance under changing load conditions.

- **Variable speed**
The inverter controls the fan speed in order to have a constant temperature.
- **Plug and Play**
Simple installation thanks to the integrated frequency inverter and temperature probe.
- **Lower operating cost**
The electric power is required only when cooling power is needed allowing lower power consumption.
- **Lower average noise level**
When less power is required the cooler generates less noise.
- **PT1000 Temperature probe with probe holder**
Accurate and reliable temperature measurement, no need to drain the cooling system when probe replacement is needed.
- **Fail-Safe operation**
Operation at maximum speed in case of Probe failure detection (open or short circuit).
- **Own safety**
If during operation the electronic overheats, fan speed drops automatically.
- **Software interface**
A user friendly interface is available to check and modify all the parameters directly on site (see also Technical Data).

Options

Integrated pressure bypass valve (IBP) / Integrated thermal pressure bypass valve (IBT)

The bypass channel is integrated in the cooling element. If a particular pressure is exceeded, the IBP opens the bypass channel, thereby protecting the cooling element from too high a pressure. Furthermore, the IBT only opens the cooling element path once a particular temperature has been reached.

Design

AC-LN 8-9-10-11 MI

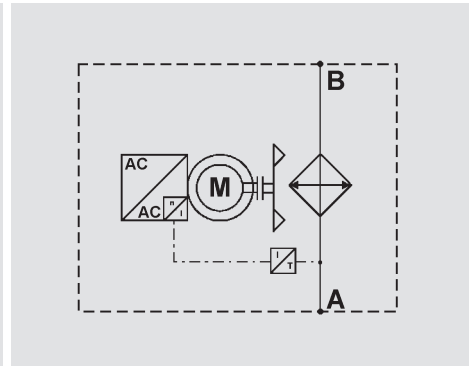
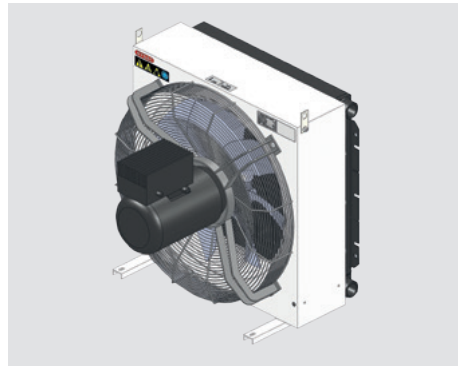

- 1 Motor with integrated inverter
- 2 Axial fan
- 3 Fan housing
- 4 Heat exchanger

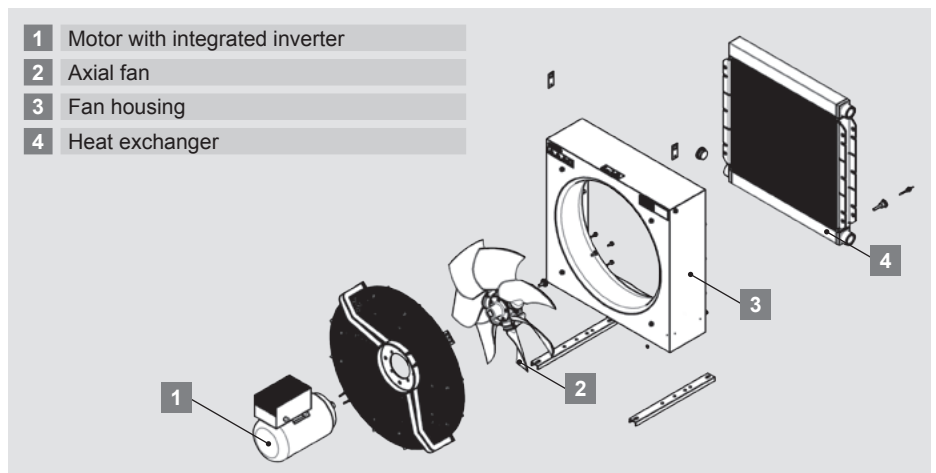

AC-LN 12-14 MI

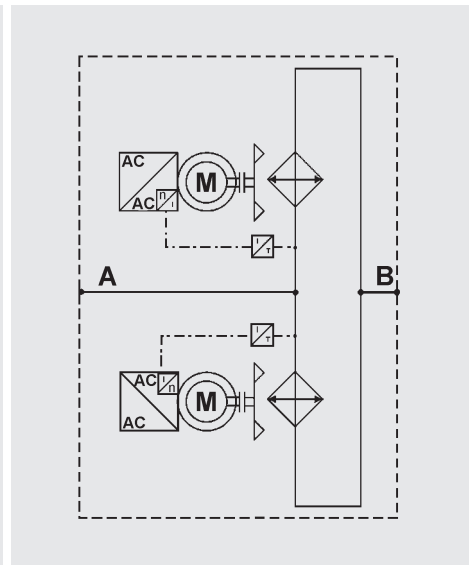

- 1 Motor with integrated inverter
- 2 Axial fan
- 3 Fan housing
- 4 Heat exchanger

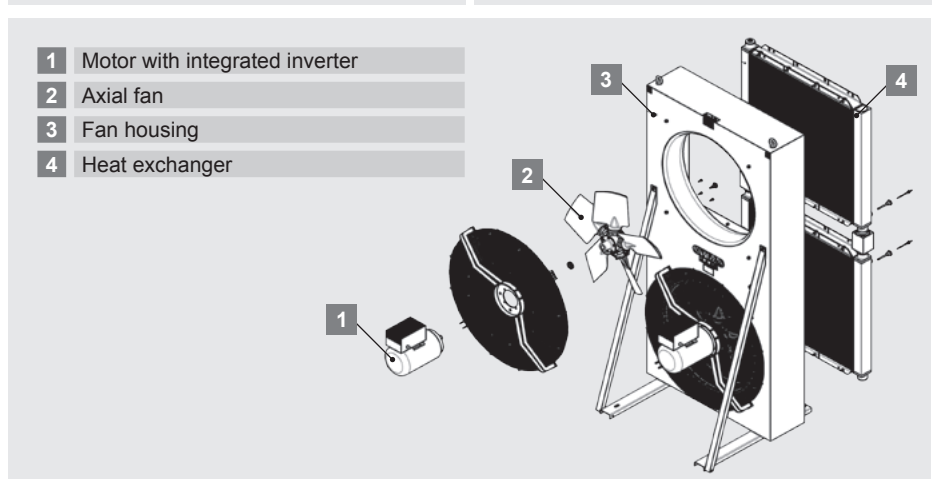

Technical Data

AC-LN MI

Type of cooler	P/N	Fluid [-] ¹⁾	Fluid flow [l/min] ²⁾	Air flow [m ³ /h]	Fan motor ³⁾ : Poles / size / flange	Noise level (at 1m distance, max. speed) [dB(A)] ⁴⁾	Volumen [l] ⁵⁾	Weight [kg] ⁵⁾
AC-LN8 MI	3876113	F	350	10,400	4/100/B14	83	6	72
AC-LN9 MI	3881548	F	350	12,400	4/100/B14	82	11	100
AC-LN10 MI	3881719	F	540	16,500	4/100/B14	84	14	129
AC-LN11 MI	3881975	F	540	18,300	6/112/B14	75	18	170
AC-LN12 MI	3882527	F	840	33,000	4/100/B14	87	28	290
AC-LN14 MI	3882659	F	840	36,600	6/112/B14	78	35	320

¹⁾ Medium: F = mineral oil or water-glycol, M = mineral oil

²⁾ Max. flow rate

³⁾ AC-LN 12-14 MI: each motor

⁴⁾ The average noise level could be lower than the values indicated.

⁵⁾ Fluid in cooling element

⁶⁾ Unfilled

Frequency inverter data

Motor Type	3 phase single winding with 3 phase frequency inverter on board
Pole Nr.	4 or 6
Power Supply	3 phases 350 – 520 Vac 47 – 64 Hz
Nominal Power	2.2 kW @ 400 V
Max. current absorption	10 A
Protection Rating	IP55
Insulation Class	F
Service	S1
Mounting	IMB14
Frame size	100 (4 Pole), 112 (6 Pole)

Temperature control

The fan frequency will be controlled by the measured fluid temperature according to the following diagram.

Note

The inverter parameters are set according to the customer requirements before cooler dispatch. For on site parameters modification a free software interface is available at the HYDAC homepage www.hydac.com.

The needed programming cable has to be ordered separately (HYDAC P/N: 3880225).

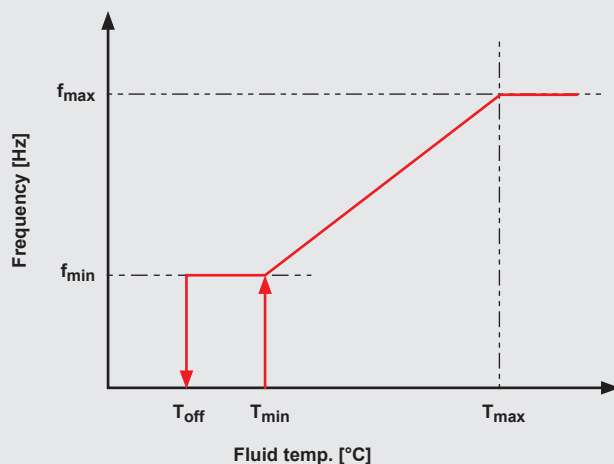

T_{min}	Temperature at which the inverter starts the fan [°C]
T_{max}	Temperature at which the inverter turns the fan to max. speed [°C]
T_{off}	Temperature at which the inverter stops the fan [°C]
f_{min}	Min. speed (starting speed)
f_{max}	Max. speed

PT1000 Temperature Probe

The platinum resistance PT1000 temperature probe offers reliable and accurate temperature measurement. At the AC-LN MI the probe is installed directly in the cooling element with a probe holder.

Probe failure detection:

In case of short or open circuit the fan will rotate continuously with maximum speed.



Working range	-20 °C ... +130 °C
Resistance at 0 °C	1,000 Ohm
Measure accuracy	<1 %

Temperature probe with probe holder

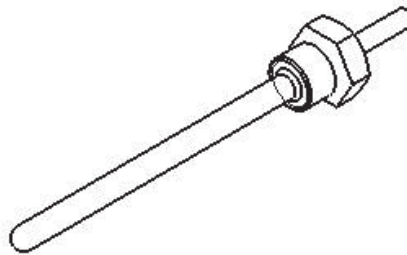

Cooling Capacity and Pressure Difference Δp

Mineral oil

AC-LN MI

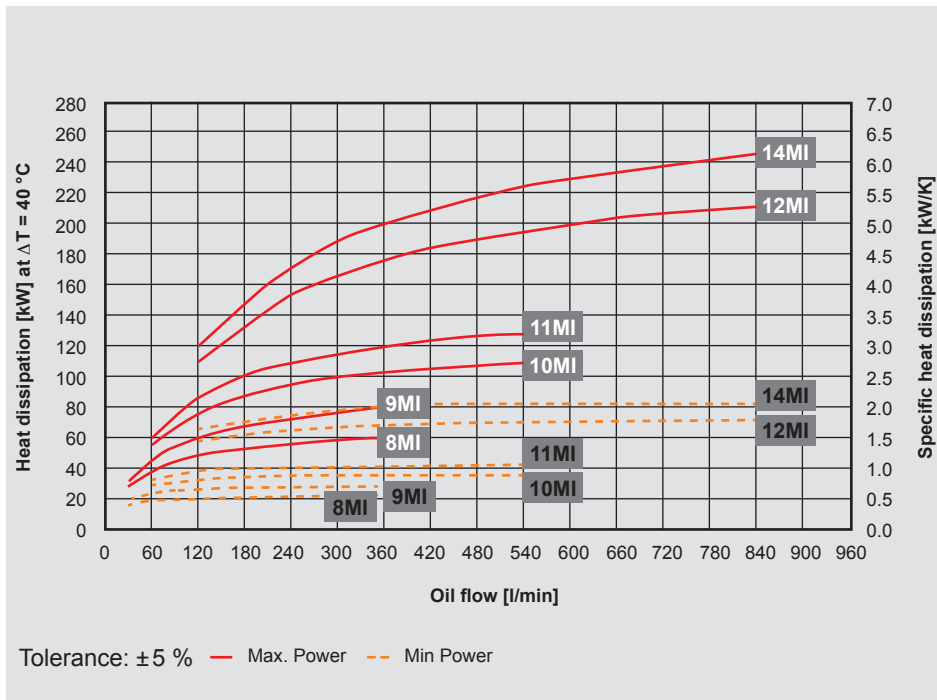

Cooling capacity:

Dependent on the oil flow rate and the temperature difference ΔT between oil inlet and air inlet.

Note:

The values are measured at $\Delta T = 40\text{ °C}$. For smaller ΔT values, the values can change. You can also use our cooler calculation software for designing. Please contact our technical sales department.

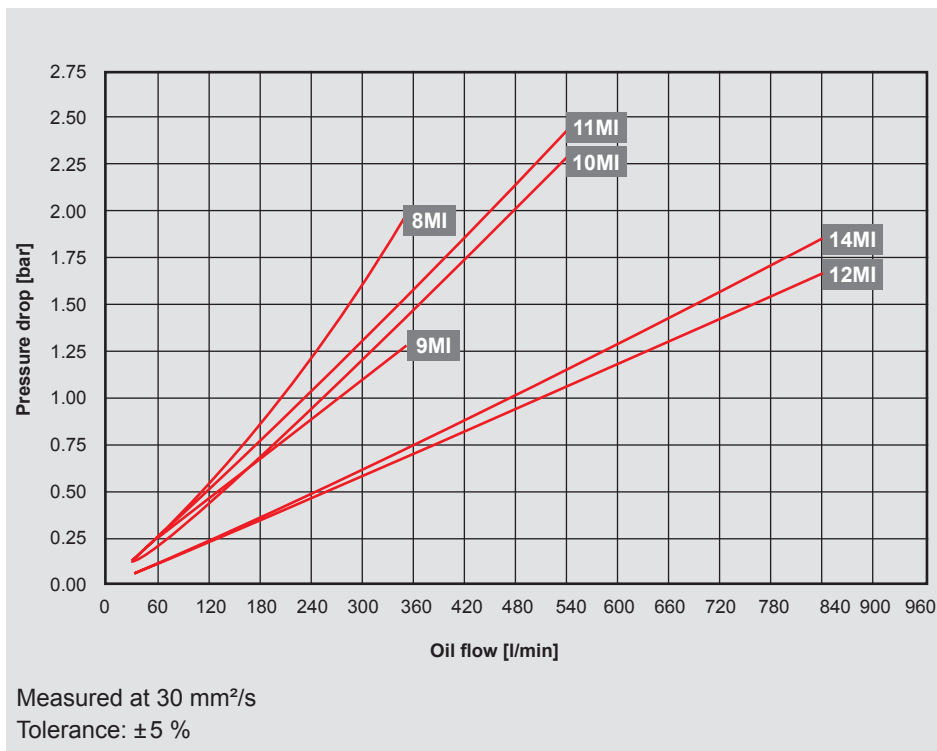

Pressure difference Δp

For other viscosities, the pressure loss must be multiplied by the conversion factor K:

Viscosity (mm^2/s)	10	15	22	30	46	68	100	150
Factor K	0.35	0.5	0.75	1	1.4	1.9	2.5	3.5

Cooling Capacity and Pressure Difference Δp

Water-glycol (60/40)

AC-LN MI

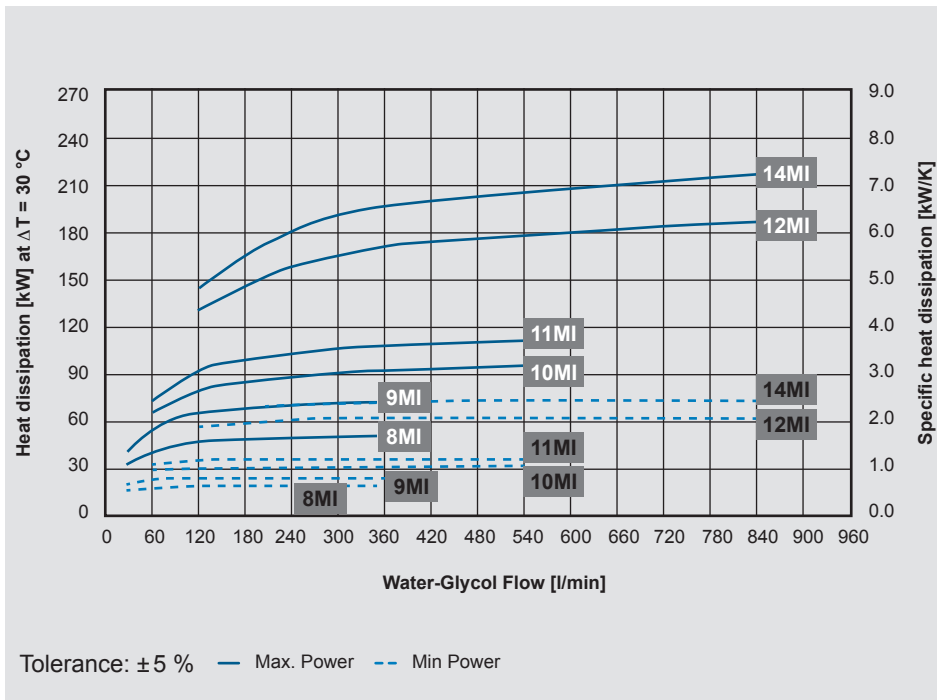

Cooling capacity:

Dependant on the water-glycol flow rate and the temperature difference ΔT between w/g inlet and air inlet.

Note:

The values are measured at $\Delta T = 30\text{ °C}$. For smaller ΔT values, the values can change. You can also use our cooler calculation software for designing. Please contact our technical sales department.

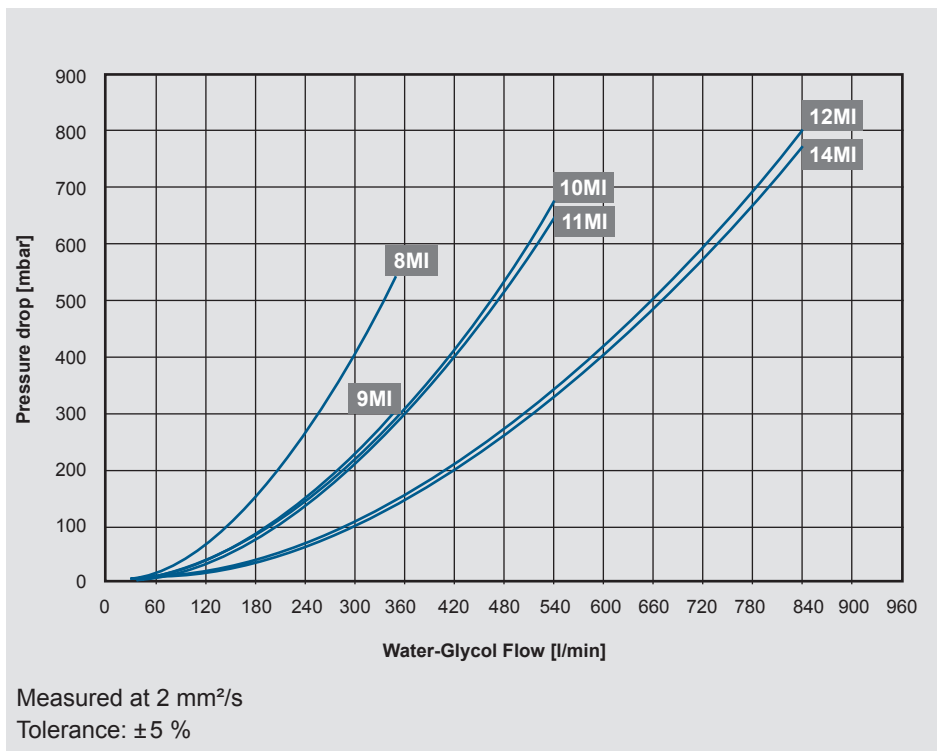

Pressure difference Δp

Model Type

AC-LN 8MI - 1.0 - F - A - 1 - IBT

Cooler type

AC-LN = Air cooler (mineral oil or water glycol mix)

Size – Motor speed min. / max.

8MI = 400 / 1,800 min⁻¹

9MI = 400 / 1,800 min⁻¹

10MI = 400 / 1,500 min⁻¹

11MI = 600 / 1,200 min⁻¹

12MI = 400 / 1,500 min⁻¹

14MI = 600 / 1,200 min⁻¹

Revision

Fluids

F = Mineral oil or water glycol mix

Motor voltage

Supply

voltage = 350 – 520 V

Color

1 = RAL 9002 (standard)

Other colors on request.

Accessories

IBP = Heat exchanger with integrated bypass valve

IBT = Heat exchanger with integrated thermo-bypass valve

For all possible accessories, like vibration absorber, air filter grid or air filter mat please refer to brochure “Accessories for air coolers”

Dimensions

AC-LN 8-9-10-11 MI

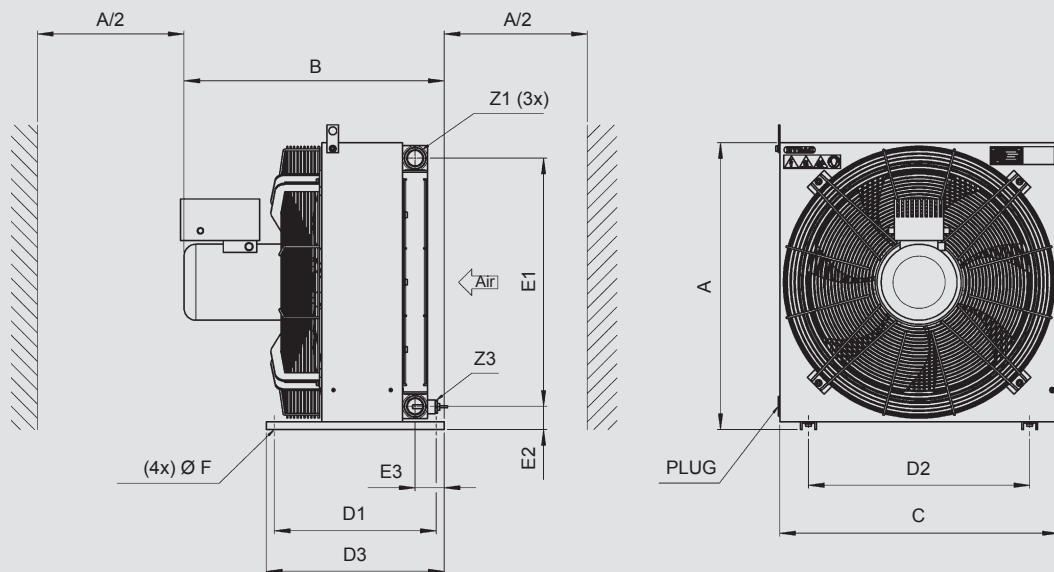

AC-LN 12-14 MI

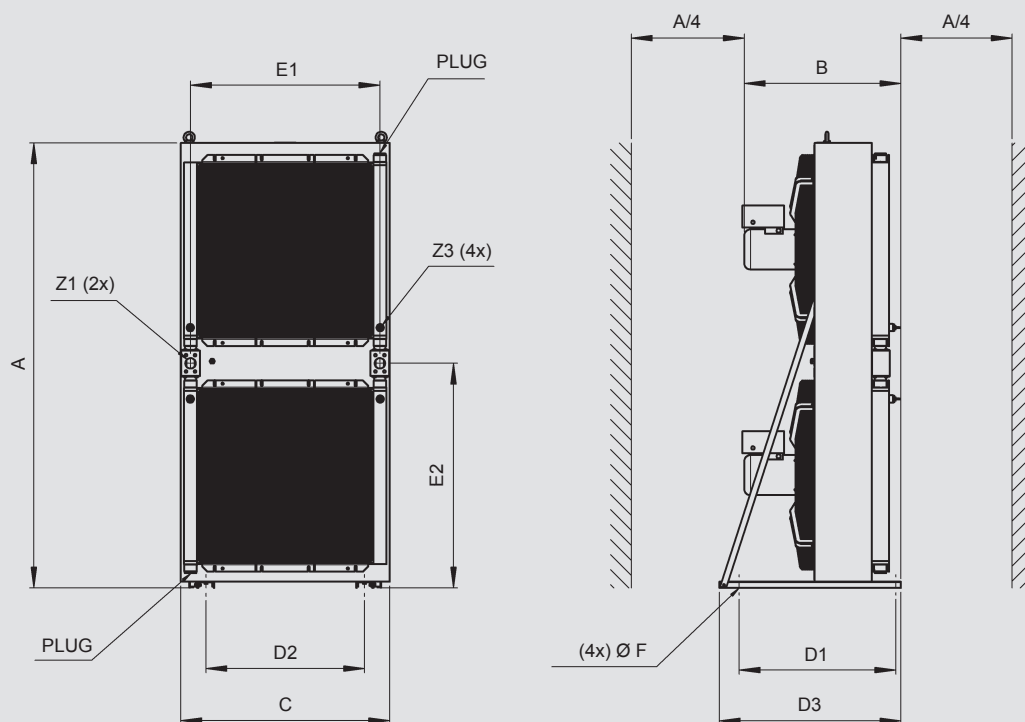

[mm]	A ±10	B ±25	C ±10	D1 ±2	D2 ±2	D3 ±2	E1 ±5	E2 ±5	E3 ±5	F Ø Loch	Z1	Z3
AC-LN8 MI	725	659	705	410	560	450	627	58.0	74	9x20	G 1-1/4"	M22x1,5
AC-LN9 MI	880	813	790	750	700	790	757	76.5	148	12	G 1-1/2"	M22x1,5
AC-LN10 MI	1,030	799	930	750	700	790	907	76.5	147	12	G 1-1/2"	M22x1,5
AC-LN11 MI	1,180	813	1,050	750	700	790	1,057	76.5	147	12	G 1-1/2"	M22x1,5
AC-LN12 MI	2,130	751	1,000	750	760	870	907	1,075.0	-	13x30	SAE 2"	M22x1,5
AC-LN14 MI	2,297	764	1,140	750	900	870	1,057	1,166.0	-	13x30	SAE 2"	M22x1,5

Note:

We recommend maintaining a minimum distance to ensure an unimpeded air inlet and air outlet. For sizes 8-11 this is half the height of the cooling element ($A/2$); for sizes 12-14 it is a quarter of the element height ($A/4$). Anything below the minimum distance can influence the cooling capacity and the noise emissions.

Note

The information in this brochure relates to the operating conditions and applications described.

For applications and operating conditions not described, please contact the relevant technical department. Subject to technical modifications.



HYDAC COOLING GMBH

INTERNATIONAL

Industriegebiet
66280 Sulzbach/Saar
Germany

Tel.: +49 6897 509-01
Fax: +49 6897 509-454

E-mail: cooling@hydac.com
Internet: www.hydac.com

**HYDAC AG
Mezzovico Branch**

Via Sceresca, Zona Industriale 3
6805 Mezzovico
Switzerland

Tel.: +41 91 9355-700
Fax: +41 91 9355-701

E-mail: info@hydac.ch
Internet: www.hydac.com

Air Cooler Industry OSCA / OSCAF 0-3

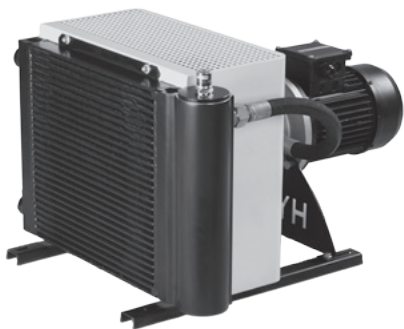

Symbol

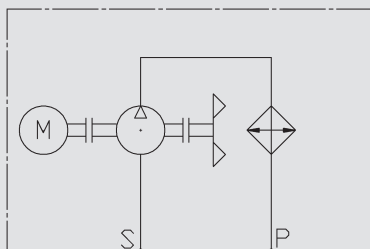

General

The low noise coolers of OSCA / OSCAF series are mostly used in small and medium hydraulic systems. Compact and efficient they offer high performance with a low noise level in a modular design.

The OSCA models with integrated oil circulation pump provide efficient off-line cooling of the hydraulic fluid. The OSCAF models with integrated (inside-outside) filter provide additional filtration, using the latest high capacity filter dirt holding development.

Product Features

Installed off-line, the OSCAF provides efficient cooling and filtration of the hydraulic fluid regardless of the duty cycle of the hydraulic system. And, the cooler can be sized perfectly to the necessary cooling performance, rather than to the maximum return-line flow rate. Off-line installation will also eliminate flow variances of the hydraulic fluid and resulting pressure spikes which potentially could lead to a premature cooler failure.

Operation Data

Fluids	Oils (mineral oils, synthetic oils, high viscosity oils, biological oils, phosphate ester)
Viscosity	500 mm ² /s
Temperature range	<p>Minimum / maximum ambient temperature: -20 °C bis +40 °C (Standard)</p> <p>Minimum / maximum temperature of the medium: +20 °C bis +90 °C</p> <p>Please contact the technical sales department in the event of deviating temperatures for applications with water-glycol.</p> <p>Notice! Fan switching frequency at max. fan speed (max. volume of air) must be avoided when operating a cooler at which the temperature difference between the medium inlet at the cooler and the ambient temperature can be greater than 50 °C. Quick changes in the temperature of the cooling element material can lead to a significant reduction in service life or to direct damage of the cooling element due to thermal shock. Please contact the technical sales department to receive information about controlled fan drives.</p>
Fan	Radial fan in suction version (standard)
Motor	<p>Three-phase motor</p> <p>Efficiency class IE2 (only ≥0.75 kW)</p> <p>Protection class IP55</p> <p>Insulation class F</p> <p>Other versions on request.</p>
Pump	<p>Screw pump</p> <p>Operating pressure: max. 10 bar</p> <p>Negative suction pressure of pump: max. -0,4 bar</p>
Noise levels	<p>See technical data.</p> <p>The noise levels are only reference values as the acoustic properties of a room, connections and reflection have an effect on the noise level.</p>

- Stable cooling and filtration (independent of the cycle times of the system)
- Avoidance of pressure surges in the cooling element
- Design of the cooler is in accordance with the cooling capacity required (not according to the maximum possible return flow volume)

Low noise

- Utilizes compact low noise screw pump

Compact

- Small in size and low in weight
- Easy to attach external exhaust ducts

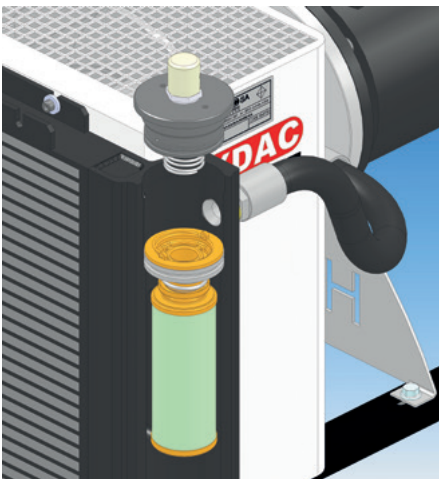

Compact: filter integrated in heat exchanger

Efficient

- Integration of several features in one unit: pumping, cooling, filtration
- No additional piping; fewer potential leak points
- Integrated filter with inside-outside filter technology; magnetic particle trap and standard 2.5 bar pressure bypass included
- Low and easy maintenance (only one plug to remove for filter element change)

Application Field

Systems with small and medium hydraulic systems, such as:

- Lubrication systems
- Machine tools
- Hydraulic presses
- Hydraulic systems
- Hydraulic lifts

Design

OSCA 0

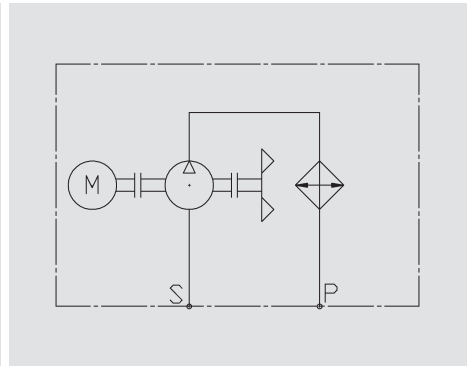

- 1 Motor
- 2 Screw pump
- 3 Radial fan
- 4 Fan housing
- 5 Heat exchanger

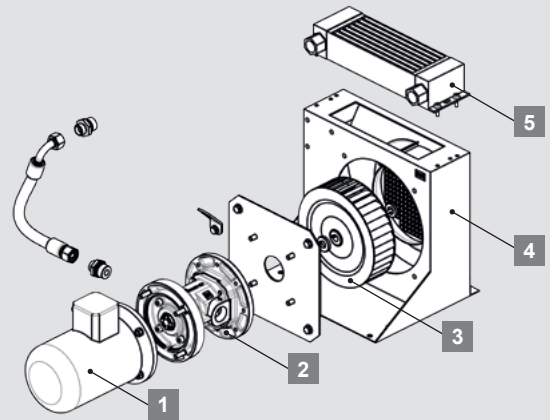

OSCA 1-3

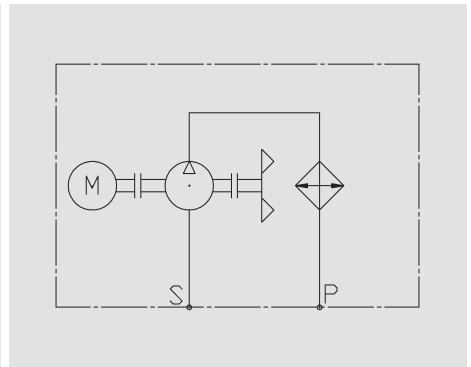

- 1 Motor
- 2 Screw pump
- 3 Fan housing
- 4 Radial fan
- 5 Heat exchanger

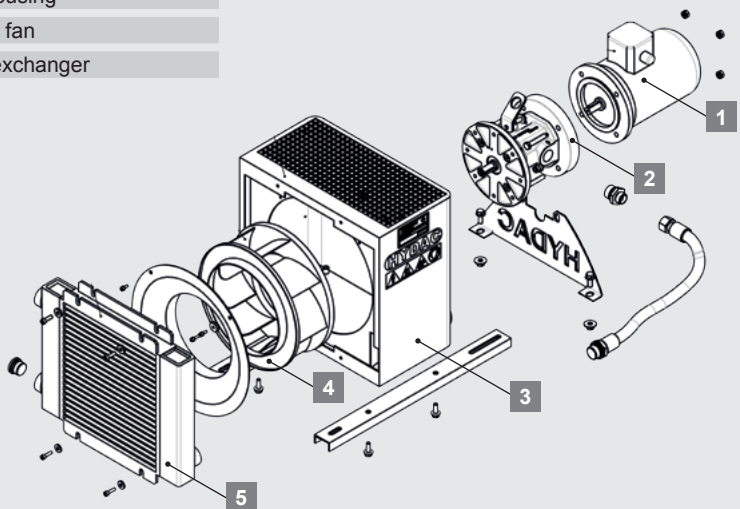

Design

OSCAF 0

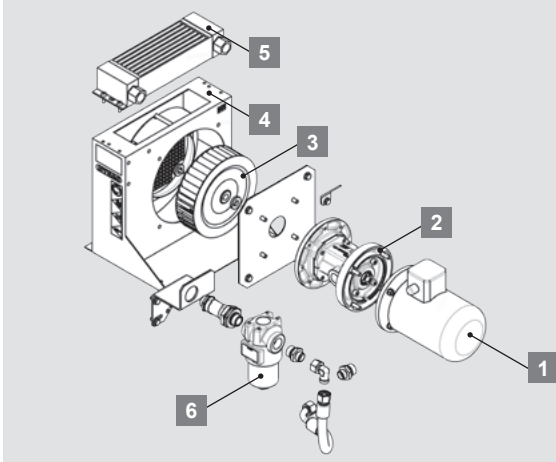
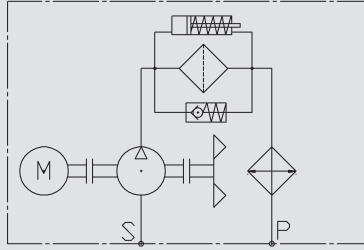
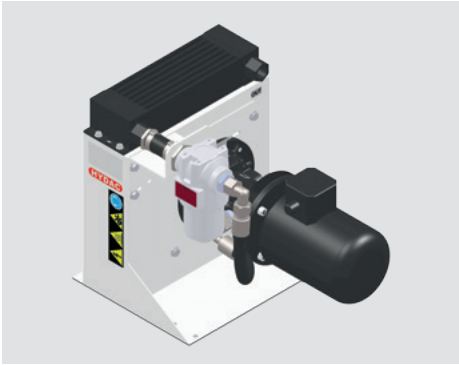

- 1 Motor
- 2 Screw pump
- 3 Radial fan
- 4 Fan housing
- 5 Heat exchanger
- 6 External filter

OSCAF 1-3

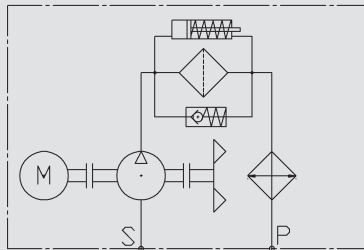
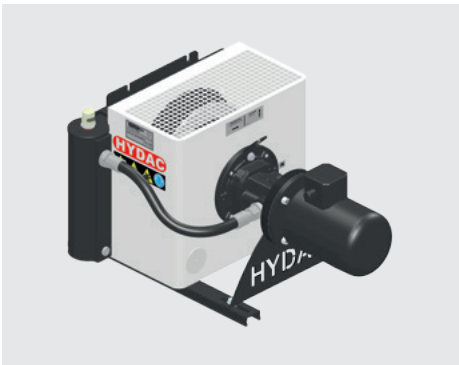

- 1 Motor
- 2 Screw pump
- 3 Radial fan
- 4 Fan housing
- 5 Heat exchanger
- 6 Integrated filter

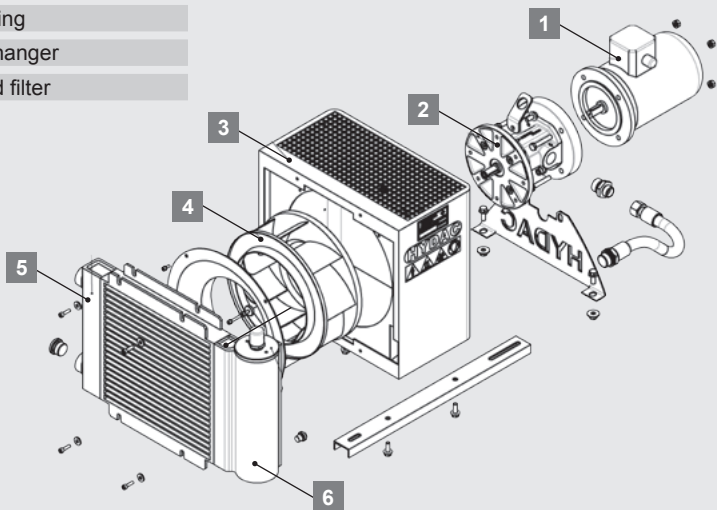

Technical Data

OSCA/OSCAF

Type of cooler	P/N	Heat dissipation at $\Delta T = 40\text{ °C}$ [kW] ¹⁾	Pressure drop [bar] at 30 mm ² /s ¹⁾	Displacement [cm ³ /U]	Oil flow [l/min] [40 cSt – 4 bar]	Air flow [m ³ /h]	Motor: N° of poles / Size	Motor: Power [kW] ²⁾	Nominal current [A] @ 400 V 50 Hz	Noise level at 1 m distance at 50 / 60 Hz [dB (A)]	Size of filter [-]	Volume [l] ³⁾	Weight [kg] ⁴⁾
OSCA 0L	3926218	1.5	0.11	10	10	155	6/71	0.25	1.0	56/60	-	0.5	20
OSCA 0S	3926219	1.8	0.19	10	15	300	4/71	0.37	1.2	63/67	-	0.5	20
OSCAF 0L	3926223	1.5	0.11	10	10	155	6/71	0.25	1.0	56/60	LF60	0.5	25
OSCAF 0S	3926222	1.8	0.19	10	15	300	4/71	0.37	1.2	63/67	LF60	0.5	25
OSCA 1L	3768893	3.7	0.08	10	10	600	6/71	0.25	1.0	59/63	-	0.9	28
OSCA 1S	3684999	4.3	0.12	10	15	870	4/71	0.37	1.2	66/70	-	0.9	28
OSCAF 1L	3769020	3.7	0.13	10	10	600	6/71	0.25	1.0	59/63	NG080	1.6	31
OSCAF 1S	3708807	4.3	0.18	10	15	870	4/71	0.37	1.2	66/70	NG080	1.6	31
OSCA 2L	3647770	7.0	0.30	28	28	1,200	6/90	0.75	2.0	60/64	-	1.4	40
OSCA 2S	3647749	9.2	0.45	28	40	1,750	4/90	1.10	2.5	69/73	-	1.4	40
OSCAF 2L	3647771	7.0	0.50	28	28	1,200	6/90	0.75	2.0	60/64	NG080	2.4	43
OSCAF 2S	3647750	9.2	0.85	28	40	1,750	4/90	1.10	2.5	69/73	NG080	2.4	43
OSCA 3L	3764555	11.6	0.25	28	28	2,350	6/90	1.10	2.7	67/71	-	2.0	63
OSCA 3S	3672255	15.0	0.38	28	40	3,400	4/90	1.80	3.7	77/81	-	2.0	63
OSCAF 3L	3764557	11.6	0.44	28	28	2,350	6/90	1.10	2.7	67/71	NG080	3.3	66
OSCAF 3S	3675061	15.0	0.75	28	40	3,400	4/90	1.80	3.7	77/81	NG080	3.3	66

¹⁾ At 50 Hz

²⁾ IE2 (only for $\geq 0,75$ kW)

³⁾ Fluid in cooling element

⁴⁾ Unfilled

For other viscosities, the pressure loss must be multiplied by the conversion factor K:

Viscosity (mm ² /s)	10	15	22	32	46	68	100	150
Factor K	0.35	0.5	0.75	1	1.4	1.9	2.5	2.3

Model Type

OSCAF - 2L - 28 - 5.0 - B - M - A - NG080 - 10 - 1 - GP

Cooler type

- OSCA = Air cooler with integrated pump
OSCAF = Air cooler with integrated pump and filter

Baugröße / Motordrehzahl

- 0-3 = Size
L = 6 pl (1,000 rpm)
S = 4 pl (1,500 rpm)

Displacement cm³/rev

- 10 = Screw pump (OSCA / OSCAF 0-1)
28 = Screw pump (OSCA / OSCAF 2-3)

Revision

Clogging indicators (only OSCAF)

- A = Without clogging indicator
B = With visual indicator (Standard)
D = With electrical and optical indicator

Fluids

- M = Mineral Oil

Motor voltage

Standard voltages and frequencies for 3 phase motor

- A = 230/400 V – 50 Hz / 265/460 V – 60 Hz

(Tolerance voltage ± 10 %)

Other voltages on request.

Size of filter (only OSCAF)

- LF60 = OSCAF 0
NG080 = OSCAF 1-2-3

Filtration rating in micron (only OSCAF)

OSCAF 0

- 5 = 5 µm Betamicron®-4-N (5 BN4HC)
10 = 10 µm Betamicron®-4-N (10 BN4HC) (Standard)
20 = 20 µm Betamicron®-4-N (20 BN4HC)

OSCAF 1-2-3

- 5 = 5 µm SHC (K-10174 NG080-5)
10 = 10 µm SHC (K-10174 NG080-10) (Standard)
20 = 20 µm SHC (K-10174 NG080-20)

Color

- 1 = RAL 9002 (Standard)

Other colors on request.

Accessories

e.g. vibration absorber

Dimensions

OSCA 0

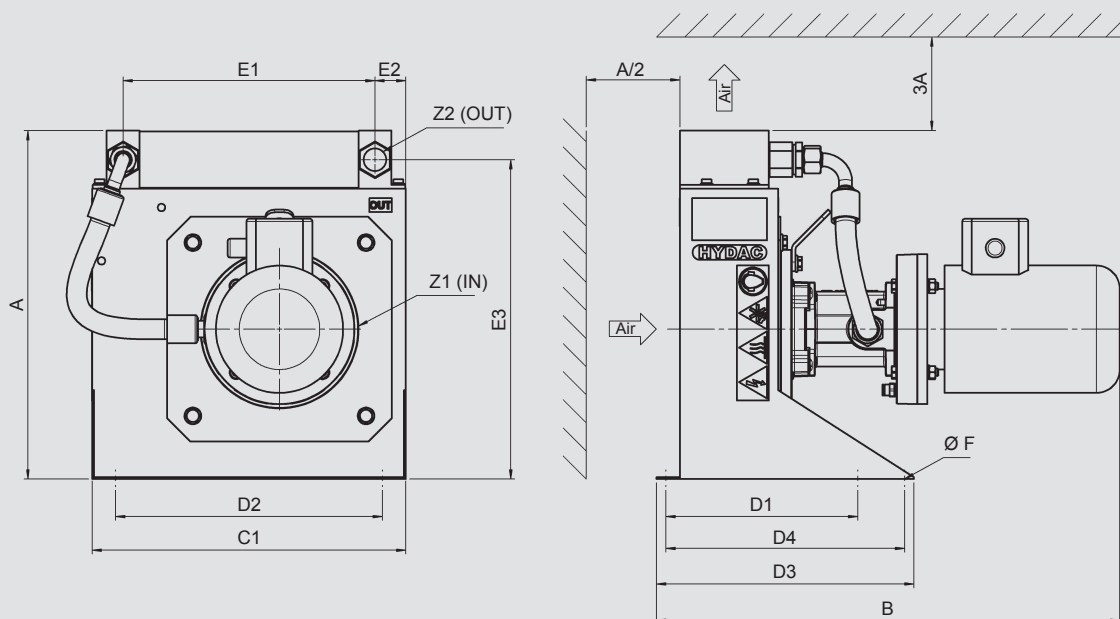

OSCA 1-3

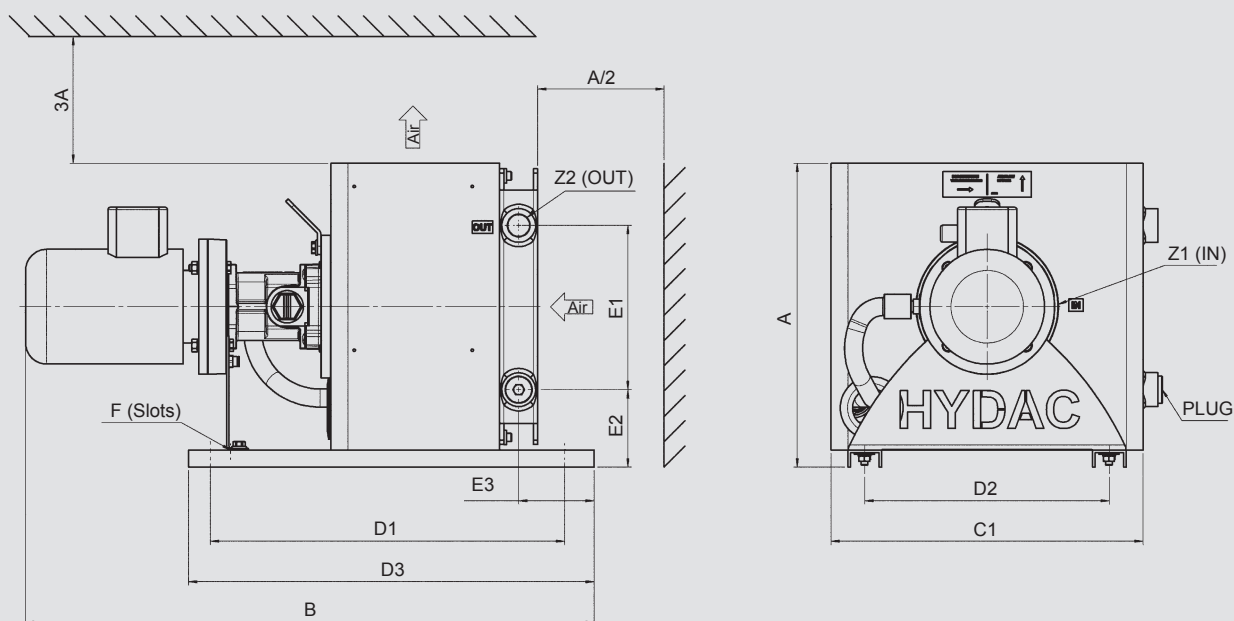

	A ±10	B ±10	C1 ±10	D1 ±2	D2 ±2	D3 ±2	D4 ±2	E1 ±2	E2 ±2	E3 ±2	F Ø Slot	Z1 (IN)	Z2 (OUT)
OSCA 0	372	495	335	205	285	275	255	269	33	341	9	G1"	G3/4"
OSCA 1	360	674	370	420	290	481	-	195	91	89.5	9	G1"	G3/4"
OSCA 2	433	766	449	455	373	521	-	288	83	72.5	9	G1"	G3/4"
OSCA 3	542	841	555	520	450	584	-	404	79	72.5	9	G1"	G3/4"

OSCAF 0

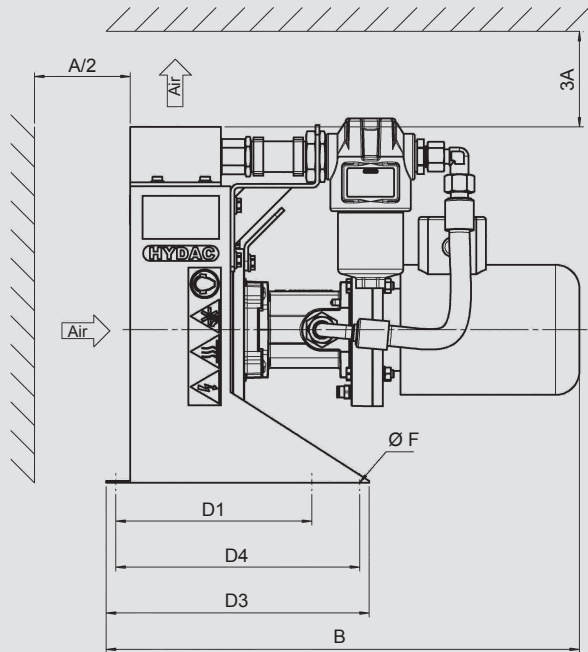
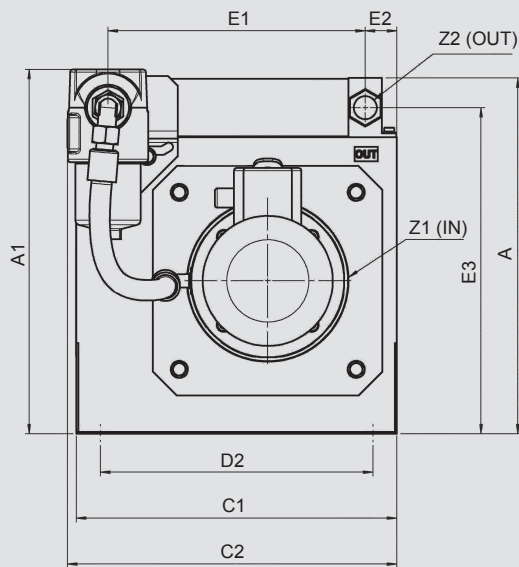

OSCAF 1-3

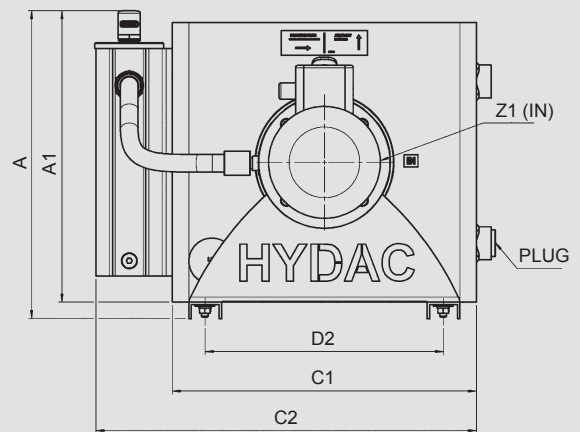
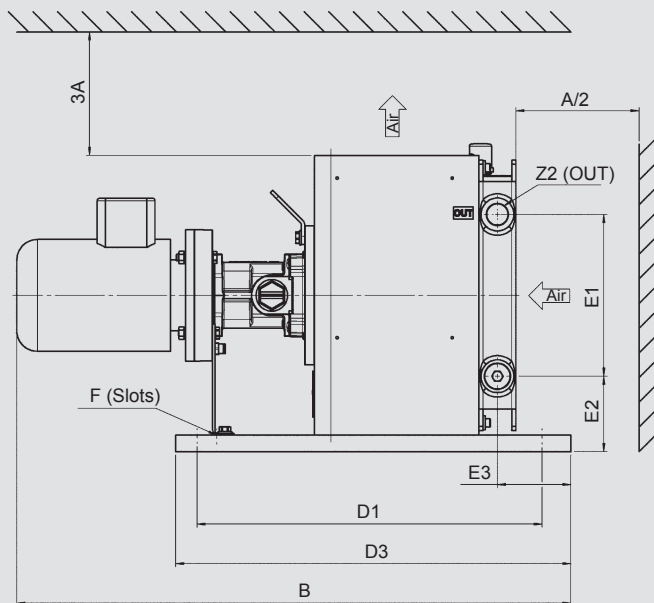

	A ±10	A1 ±10	B ±10	C1 ±10	C2 ±10	D1 ±2	D2 ±2	D3 ±2	D4 ±2	E1 ±2	E2 ±2	E3 ±2	F Ø Slot	Z1 (IN)	Z2 (OUT)
OSCAF 0	372	381	495	335	345	205	285	275	255	269	33	341	9	G1"	G3/4"
OSCAF 1	375	355	674	370	463	420	290	481	-	195	91	89.5	9	G1"	G3/4"
OSCAF 2	453	433	766	449	540	455	373	521	-	288	83	72.5	9	G1"	G3/4"
OSCAF 3	560	540	841	555	647	520	450	584	-	404	79	72.5	9	G1"	G3/4"

Note:

We recommend maintaining a minimum distance to ensure an unimpeded air inlet and air outlet. This is half the height of the cooling element (A/2). Anything below the minimum distance can influence the cooling capacity and the noise emissions.

Note

The information in this brochure relates to the operating conditions and applications described.

For applications and operating conditions not described, please contact the relevant technical department.

Subject to technical modifications.



HYDAC COOLING GMBH

Industriegebiet
66280 Sulzbach/Saar
Germany

Tel.: +49 6897 509-01
Fax: +49 6897 509-454

E-mail: cooling@hydac.com
Internet: www.hydac.com

**HYDAC AG
Mezzovico Branch**

Via Sceresca, Zona Industriale 3
6805 Mezzovico
Switzerland

Tel.: +41 91 9355-700
Fax: +41 91 9355-701

E-mail: info@hydac.ch
Internet: www.hydac.com



Air Cooler Industry OK-ELC 0-7

Symbol

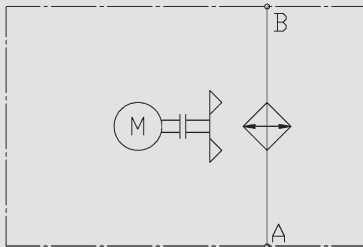

General

The OK-ELC air cooler series is designed specifically for hydraulic applications where high performance and efficiency are required and physical size must be minimized to allow easy installation.

Product Features

These coolers use a combination of high performance cooling elements and high capacity, compact AC electrically powered fans to give long trouble-free operation in arduous hydraulic applications.

The compact design allows the coolers to fit most equipment and provide the highest cooling performance in heat dissipation whilst minimizing the space required.

- Compact, efficient, high performance
- Cooling range 1 - 28 kW
- AC motors in 230/400 Volt 50/60 Hz

Application Field

Systems with small and medium cooling requirements, such as

- Industrial power units
- Lubrication systems
- Machine tools

Operation Data

Fluids	Oils (mineral oils, synthetic oils, high viscosity oils, biological oils, phosphate ester) Water-glycol (cooling fluid)
Viscosity	2,000 mm ² /s (standard)
Temperature range	<ul style="list-style-type: none"> ● Minimum / maximum ambient temperature: -20 °C to +40 °C (standard) ● Minimum / maximum temperature of the medium: +20 °C to +130 °C <p>Please contact the technical sales department in the event of deviating temperatures.</p> <p>Notice! Fan at max. speed (max. volume of air) must be avoided when operating a cooler at which the temperature difference between the medium inlet at the cooler and the ambient temperature can be greater than 50 °C. Quick changes in the temperature of the cooling element material can lead to a significant reduction in service life or to direct damage of the cooling element due to thermal shock. Please contact the technical sales department to receive information about controlled fan drives.</p>
Pressure resistance of the cooling element	<ul style="list-style-type: none"> ● Dynamic operating pressure: 16 bar ● Static operating pressure: 21 bar
Fan	Axial fan in suction version (standard) Axial fan in pushing version on request (note: approx. 10 % less cooling capacity)
Motor	<ul style="list-style-type: none"> ● AC motor ● Protection class IP20 (OK-ELC 0) Protection class IP55 (OK-ELC 1-7) ● Insulation class F <p>Other versions on request.</p>
ErP	The fan unit of the OK-ELC corresponds to the minimum efficiency levels specified in the Ecodesign directive or ErP directive (Energy-related Products) 2009/125/EC.
Noise levels	See technical data The noise levels are only reference values as the acoustic properties of a room, connections and reflection have an effect on the noise level.
Accessories	<ul style="list-style-type: none"> ● Integrated pressure bypass valve (IBP) or integrated thermal pressure bypass valve (IBT) (cannot be retrofitted, also see options) ● Thermostats ● Air filter grid or air filter mat ● Vibration damper

Options

Integrated pressure bypass valve (IBP) / Integrated thermal pressure bypass valve (IBT)

The bypass channel is integrated in the cooling element. If a particular pressure is exceeded, the IBP opens the bypass channel, thereby protecting the cooling element from too high a pressure. Furthermore, the IBT only opens the cooling element path once a particular temperature has been reached.

Design

OK-ELC 0

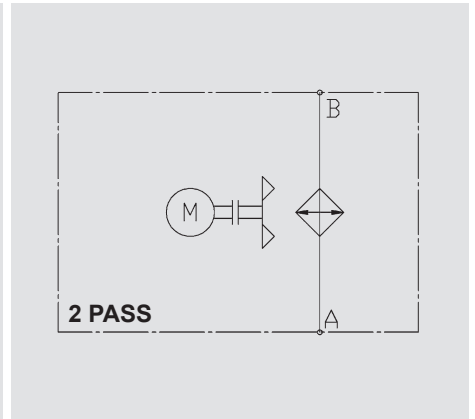
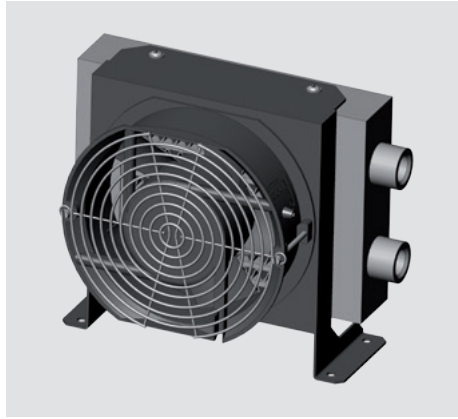

Air cooler with

- 1 Finger guard
- 2 Axial fan with integrated motor
- 3 Fan housing
- 4 Heat exchanger

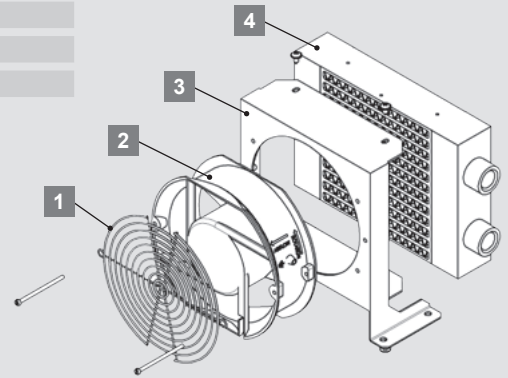

OK-ELC 1

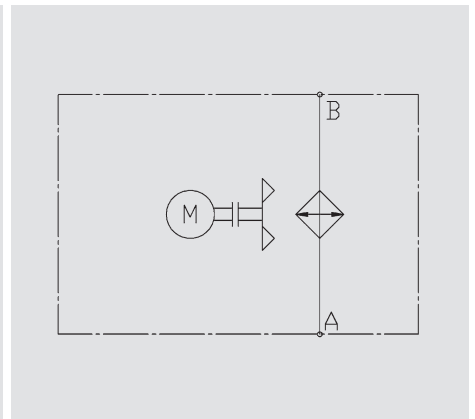

Air cooler with

- 1 Axial fan with integrated motor and finger guard
- 2 Fan housing
- 3 Heat exchanger

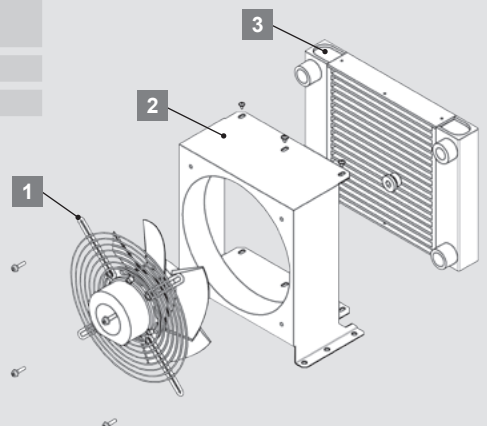

Design

OK-ELC 2-5

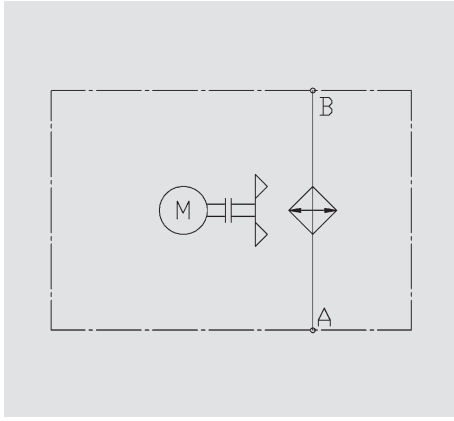
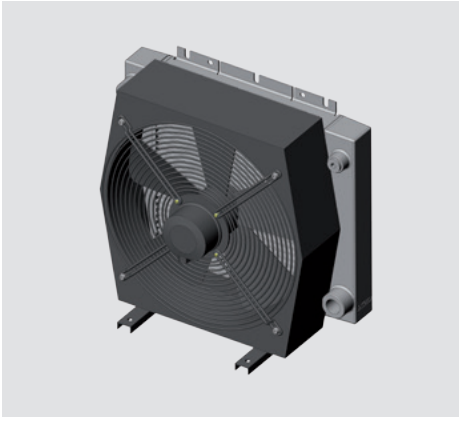

Air cooler with

- 1 Axial fan with integrated motor and finger guard
- 2 Fan housing
- 3 Heat exchanger

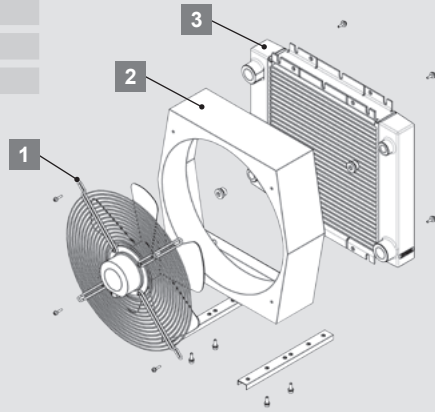

OK-ELC 6-7

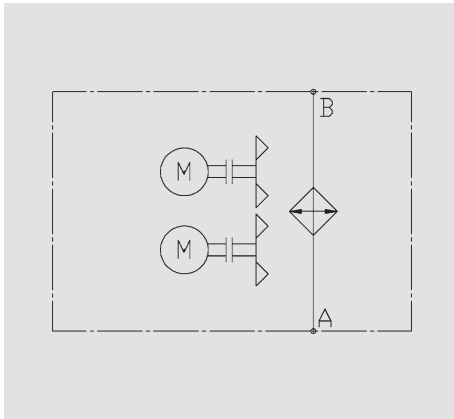
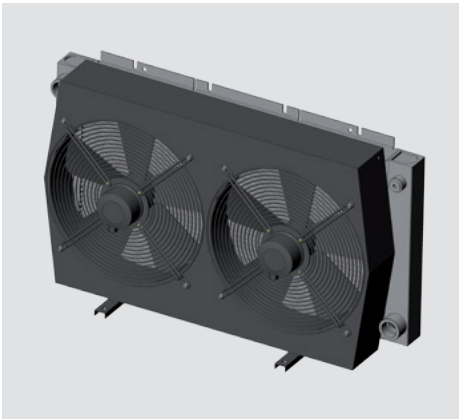

Air cooler with

- 1 Axial fan with integrated motor and finger guard
- 2 Fan housing
- 3 Heat exchanger

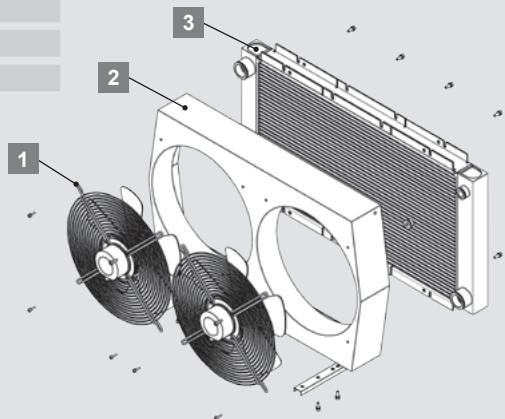

Technical Data

OK-ELC 0-7

Type of cooler	P/N	Voltage [V]	Fluid flow [l/min] ¹⁾	Air flow [m ³ /h]	N° of poles	Fan motor: Power / current absorption [kW / A] ²⁾		Capacitor [µF/VDB] ²⁾	Fan Diameter [mm] ²⁾	Noise level (at 1m distance) [dB(A)]	Volume [l] ³⁾	Weight [kg] ⁴⁾
						kW	A					
OK-ELC 0H	3115194	230	50	200	2	0.04	0.29	-	145	59	0.3	3.2
OK-ELC 1H	3117022	230	150	900	2	0.12	0.54	2/450	230	71	0.5	9.0
OK-ELC 1H	3117021	400	150	900	2	0.12	0.34	2/500	230	71	0.5	9.0
OK-ELC 2H	3110965	230	180	850	2	0.15	0.50	2/450	250	71	2.0	11.9
OK-ELC 2H	3099620	400	180	850	2	0.17	0.37	2/500	250	71	2.0	11.9
OK-ELC 3H	3108660	230	180	1,300	2	0.17	0.75	4/450	300	75	2.2	14.7
OK-ELC 3H	3100673	400	180	1,300	2	0.19	0.56	3/500	300	75	2.2	14.7
OK-ELC 4S	3979356	230	250	1,900	4	0.21	0.92	4/450	400	69	3.0	21.0
OK-ELC 4S	3979358	400	250	1,900	4	0.23	0.40	-	400	69	3.0	21.0
OK-ELC 5S	3979359	230	250	2,000	4	0.21	0.92	4/450	400	72	5.2	28.0
OK-ELC 5S	3979360	400	250	2,000	4	0.23	0.40	-	400	72	5.2	28.0
OK-ELC 6H	3115191	230	250	3,000	2	0.17	0.75	4/450	300	75	4.2	39.0
OK-ELC 6H	3106810	400	250	3,000	2	0.19	0.56	3/500	300	75	4.2	39.0
OK-ELC 7S	3115193	230	250	4,200	4	0.21	0.92	4/450	400	71	5.2	45.0
OK-ELC 7S	3106811	400	250	4,200	4	0.23	0.40	-	400	71	5.2	45.0

¹⁾ Max. flow rate

²⁾ OK-ELC 6-7: each fan

³⁾ Fluid in cooling element

⁴⁾ Unfilled

Cooling Capacity and Pressure Difference Δp

OK-ELC 0-7

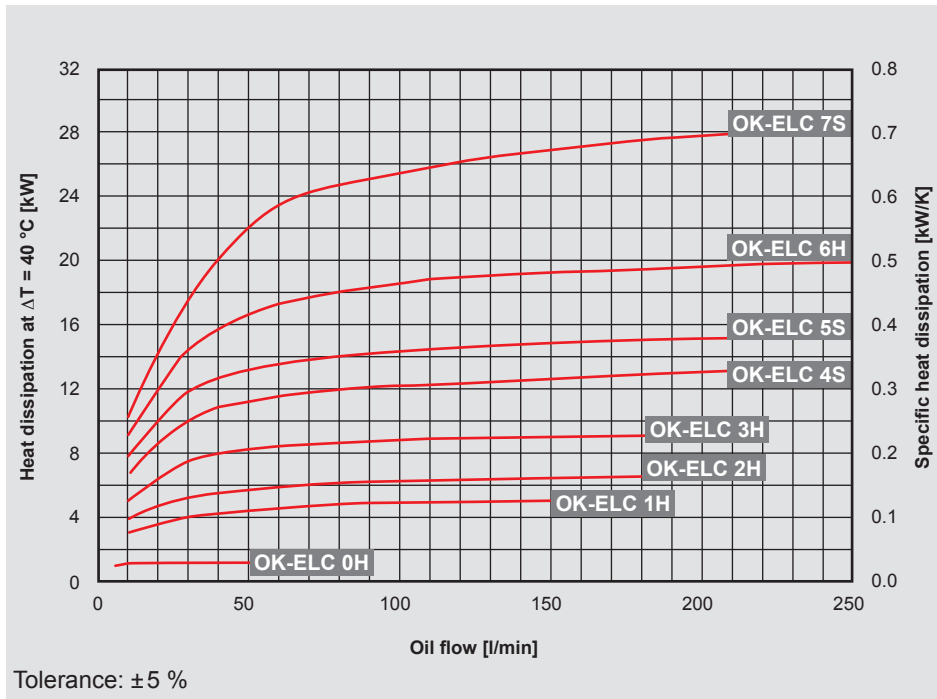

Cooling capacity:

Dependent on the oil flow rate and the temperature difference ΔT between oil inlet and air inlet.

Note:

The values are measured at $\Delta T = 40^\circ\text{C}$. For smaller ΔT values, the values can change. You can also use our cooler calculation software for designing. Please contact our technical sales department.

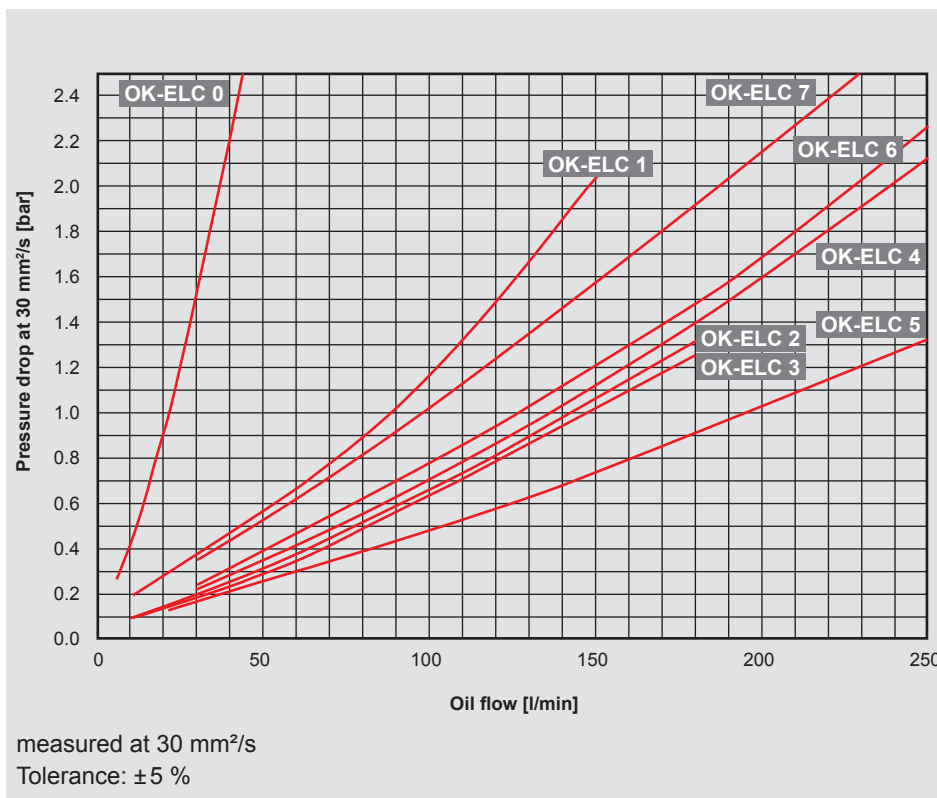

Pressure difference Δp

For other viscosities, the pressure loss must be multiplied by the conversion factor K:

Viscosity (mm^2/s)	10	15	22	30	46	68	100	150
Factor K	0.35	0.5	0.75	1.0	1.4	1.9	2.5	3.5

Model Type

OK-ELC - 1H - 1.0 - 230 V - 1 - S - AITF50

Cooler type

OK-ELC = Oil-Air cooler

Size / motor speed

0-7 = size (see cooling capacity)

H = 3,000 min⁻¹

S = 1,500 min⁻¹

Revision

Motor voltage

230 V = 230 V – 50 Hz, 220 V – 60 Hz

400 V = 400 V – 50 Hz, 440 V – 60 Hz

Color

1 = RAL 9005 (standard)

Other colors on request.

Air flow direction

S = Suction (standard)

Accessories

IBP = Heat exchanger with integrated bypass valve (not available for OK-ELC 0 and OK-ELC 1)

IBT = Heat exchanger with integrated thermo-bypass valve (not available for OK-ELC 0 and OK-ELC 1)

AITF = Thermostat (fixed)

For all possible accessories, like vibration absorber, air filter grid or air filter mat, please refer to brochure Accessories for air coolers.

Dimensions

OK-ELC 0

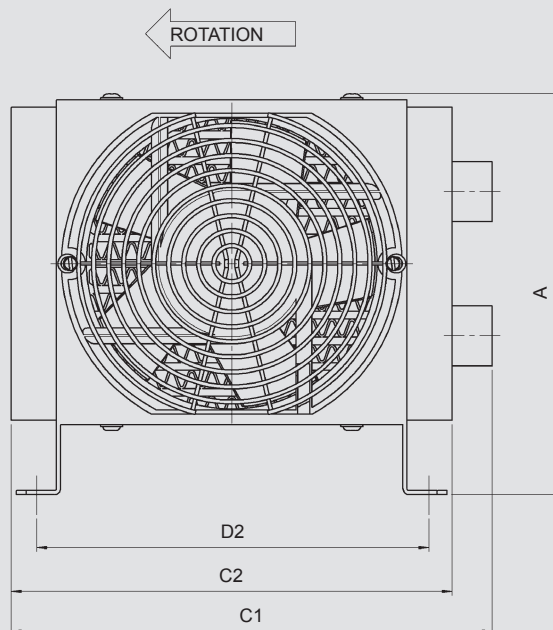
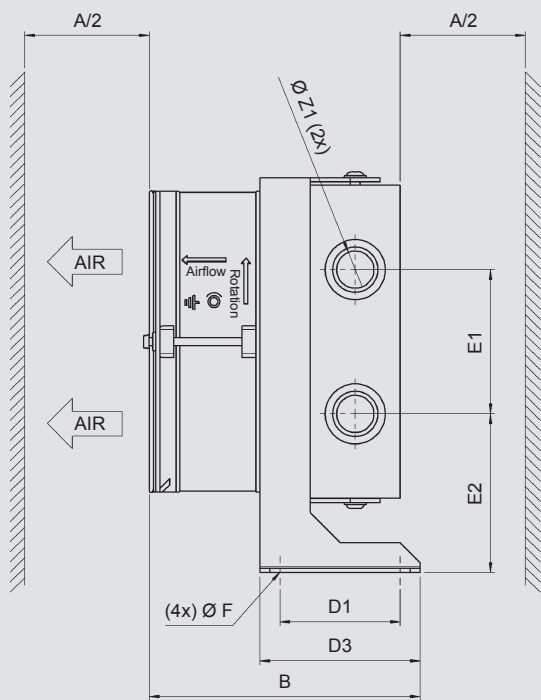

[mm]	A ±5	B ±10	C1 ±5	C2 ±5	D1 ±2	D2 ±2	D3 ±2	E1 ±5	E2 ±5	F ø/slot	Z1
OK ELC 0	200	135	240	220	60	190	80	72	79	6.5	G½"

Dimensions

OK-ELC 1

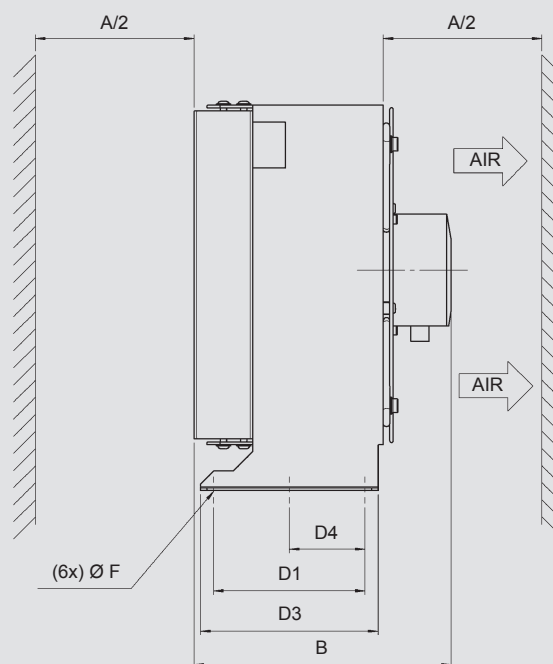
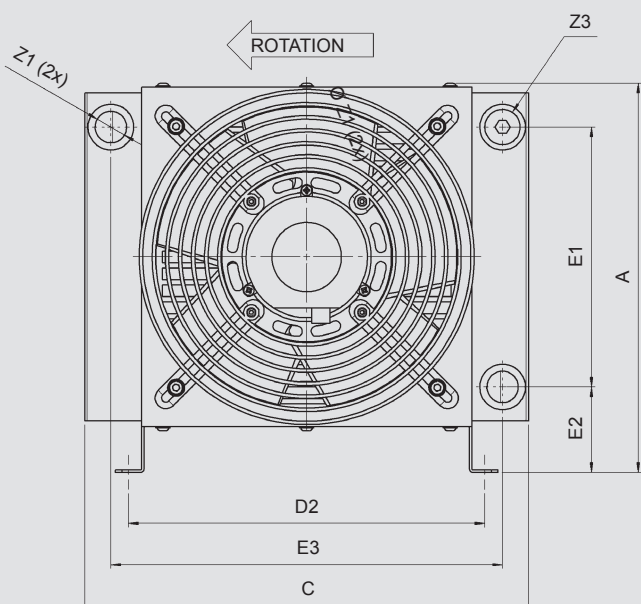

[mm]	A ±5	B ±10	C ±5	D1 ±2	D2 ±2	D3 ±2	D4 ±2	E1 ±5	E2 ±5	E3 ±5	F ø/slot	Z1	Z3
OK-ELC 1	298	197	340	110	270	136	50	200	65	300	8.5	G¾"	M22x1.5

Dimensions

OK-ELC 2-5

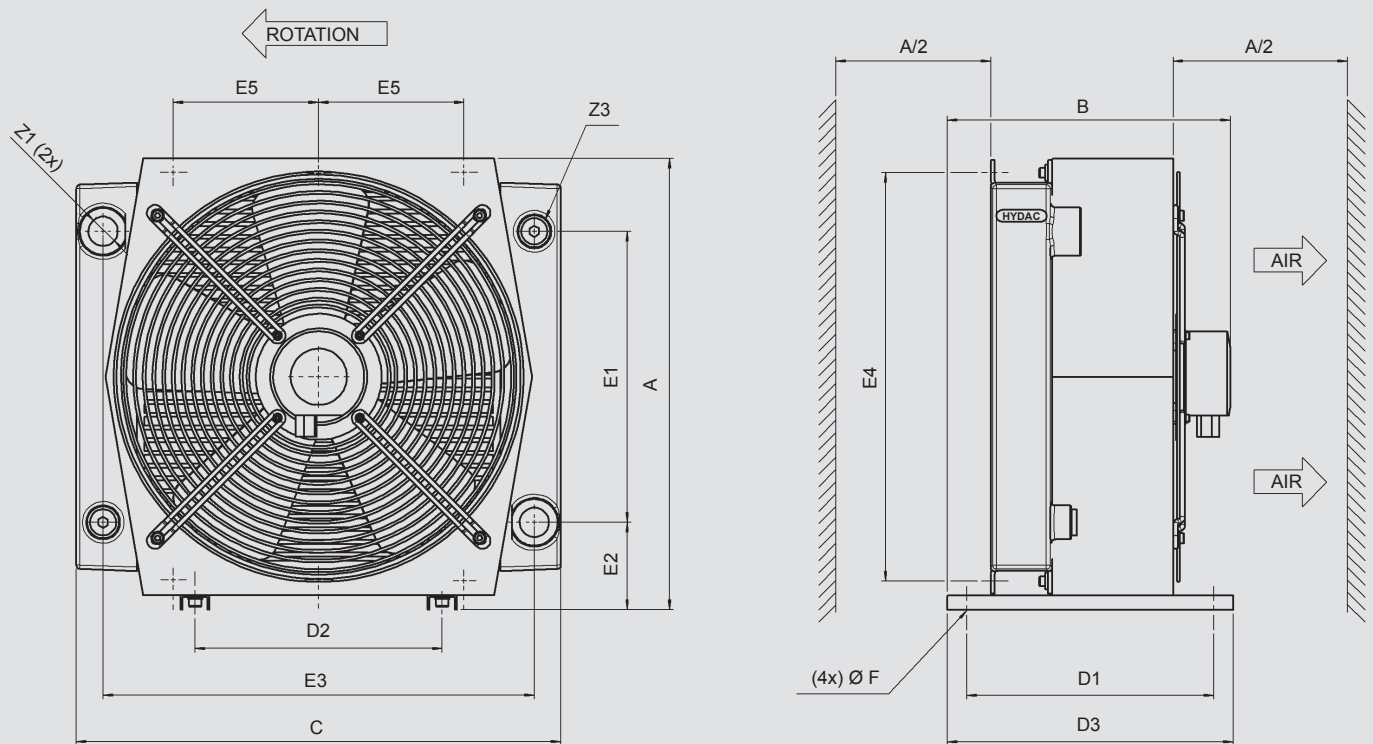

[mm]	A ±5	B ±10	C ±5	D1 ±2	D2 ±2	D3 ±2	E1 ±5	E2 ±5	E3 ±5	E4 ±5	E5 ±2	F ø/slot	Z1	Z3
OK-ELC 2	328	290	384	255	160	295	199	72	324	288	80	9	G1"	M22x1.5
OK-ELC 3	371	287	420	255	240	295	233	76	370	329	100	14x10	G1"	M22x1.5 ¹⁾
OK-ELC 4	465	292	500	255	255	295	300	90	445	421	150	19x10	G1"	M22x1.5 ¹⁾
OK-ELC 5	475	306	600	255	255	295	350	72	490	200 ²⁾	580 ²⁾	12	G1-1/4"	M22x1.5 ¹⁾

¹⁾ OK-ELC 3, OK-ELC 4 and OK-ELC 5 have two connections M22x1.5

²⁾ OK-ELC 5 has the front fixing holes in the lateral sides

Dimensions

OK-ELC 6-7

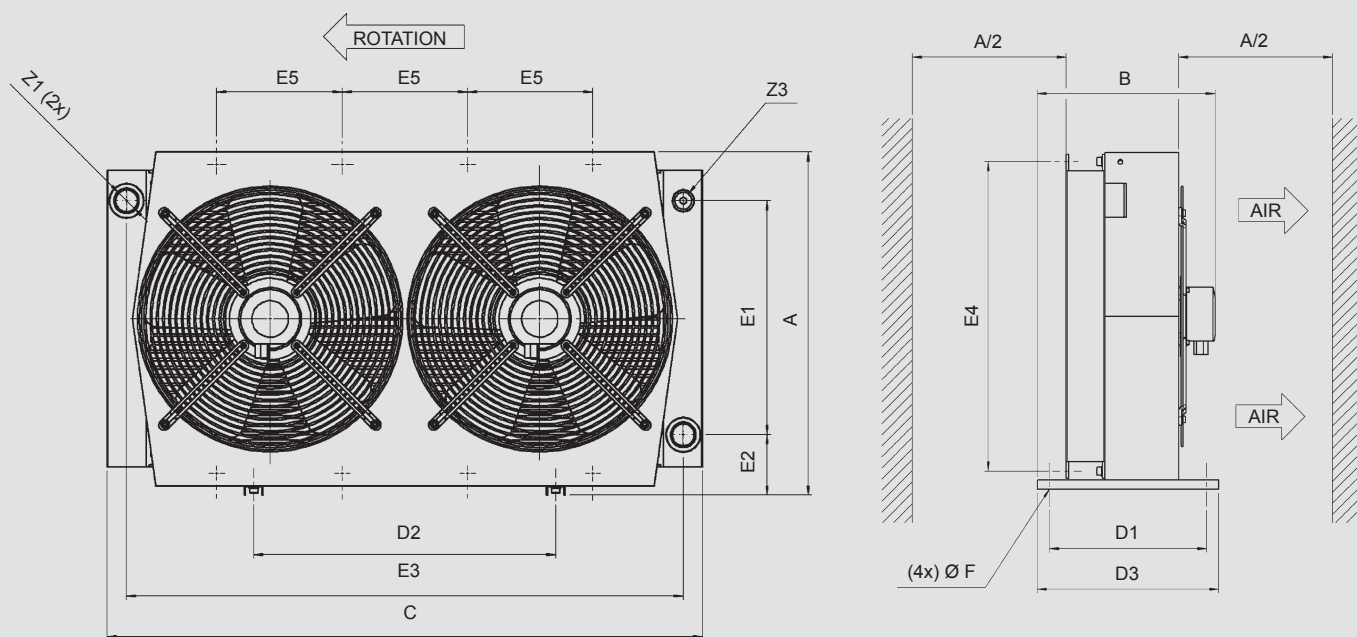

[mm]	A ±5	B ±10	C ±5	D1 ±2	D2 ±2	D3 ±2	E1 ±5	E2 ±5	E3 ±5	E4 ±5	E5 ±2	F ø/slot	Z1	Z3
OK-ELC 6	495	289	810	255	482	295	321	95	750	445	170	10x20	G1-¼"	M22x1.5
OK-ELC 7	547	289	950	255	482	295	373	96	888	503	200	9x21	G1-¼"	M22x1.5

Note:

We recommend maintaining a minimum distance to ensure an unimpeded air inlet and air outlet. This is half the height of the cooling element (A/2). Anything below the minimum distance can influence the cooling capacity and the noise emissions.

Note

The information in this brochure relates to the operating conditions.

For applications and operating conditions not described, please contact the relevant technical department.

Subject to technical modifications.



HYDAC COOLING GMBH

INTERNATIONAL

Industriegebiet
66280 Sulzbach/Saar
Germany

Tel.: +49 6897 509-01
Fax: +49 6897 509-454

E-mail: cooling@hydac.com
Internet: www.hydac.com

**HYDAC AG
Mezzovico Branch**

Via Sceresca, Zona Industriale 3
6805 Mezzovico
Switzerland

Tel.: +41 91 9355-700
Fax: +41 91 9355-701

E-mail: info@hydac.ch
Internet: www.hydac.com

Air Cooler Industry AC-MS Modular Systems

General

The new AC-MS air coolers are specifically designed to meet the needs of electric power generation applications, such as Diesel or gas generators, gas turbines, cogeneration units, gas compressors and general applications in oil and gas industry.

Product Features

Due to the high level of efficiency achieved by our aluminium cooling elements made with "plate & bar" technology, the new AC-MS coolers are designed to allow the installation inside the standard and high cube ISO 20-40 ft container, for Diesel / gas engines, gas turbines and compressors with the highest power output.

The modular design of the coolers makes possible the integration in several types of installations, and offers the possibility to expand the cooling capacity of new and existing power plants.

The AC-MS coolers may be used for cooling the following fluids:

- Engine cooling circuits
- HT High temperature circuit for jacket water
- LT Low temperature circuit for air to water charge cooler
- Charge air for Diesel and Gas turbo after-cooled engines
- Lubricating and transmission oil circuits
- Diesel fuel

Application Field

- Diesel and gas generators with a power output up to 3,000 kVA and over
- Gas turbines
- Gas compressors
- Combined heat and power applications (CHP)
- Oil & gas industry
- General industrial and fluid process cooling

Design

Depending on the specific needs of the application it is possible to choose the coolers among these three configurations:



Low Noise Coolers

- Fixed fan speed rotation
- Variable speed fan
- Ultra-silent coolers for special applications



Compact Design

- High performance in a compact design
- Side by side coolers
- Stacked coolers

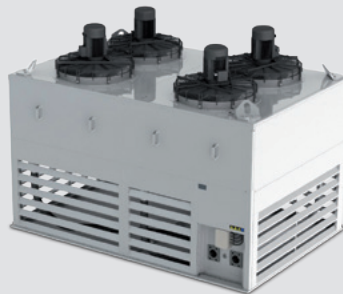

Heavy Duty Systems

- Enhanced performance
- Extreme ambient conditions

AC-MS Benefits

- Modularity: Expand your cooling capacity without limitation.
- Compactness: Design is optimized for containerized application
- High performance: Specific heat capacity up to 18 kW/K water glycol application.
- Efficiency: Low noise coolers reduce energy consumption further by use of low speed fans.
- Low cost of maintenance due to electric motor fan drives.

AC-MS Low Noise – High Efficiency

AC-MS Low noise cooler is the combination of high efficient cooling element and variable speed fans technology. Fans performances are regulated by monitoring both thermal load of the fluids and ambient temperature. Fan speed is tuned by means of system's integrated PID algorithm.

The reduced acoustic emissions of these coolers allow the installation of industrial equipment such as Diesel and gas generators, compressors and any other industrial machines needing a cooler in residential areas, hospitals, hotels, commercial buildings and schools.

Horizontal air flow direction

Vertical lay-out



Horizontal lay-out



Vertical air flow direction

V-shape cooler

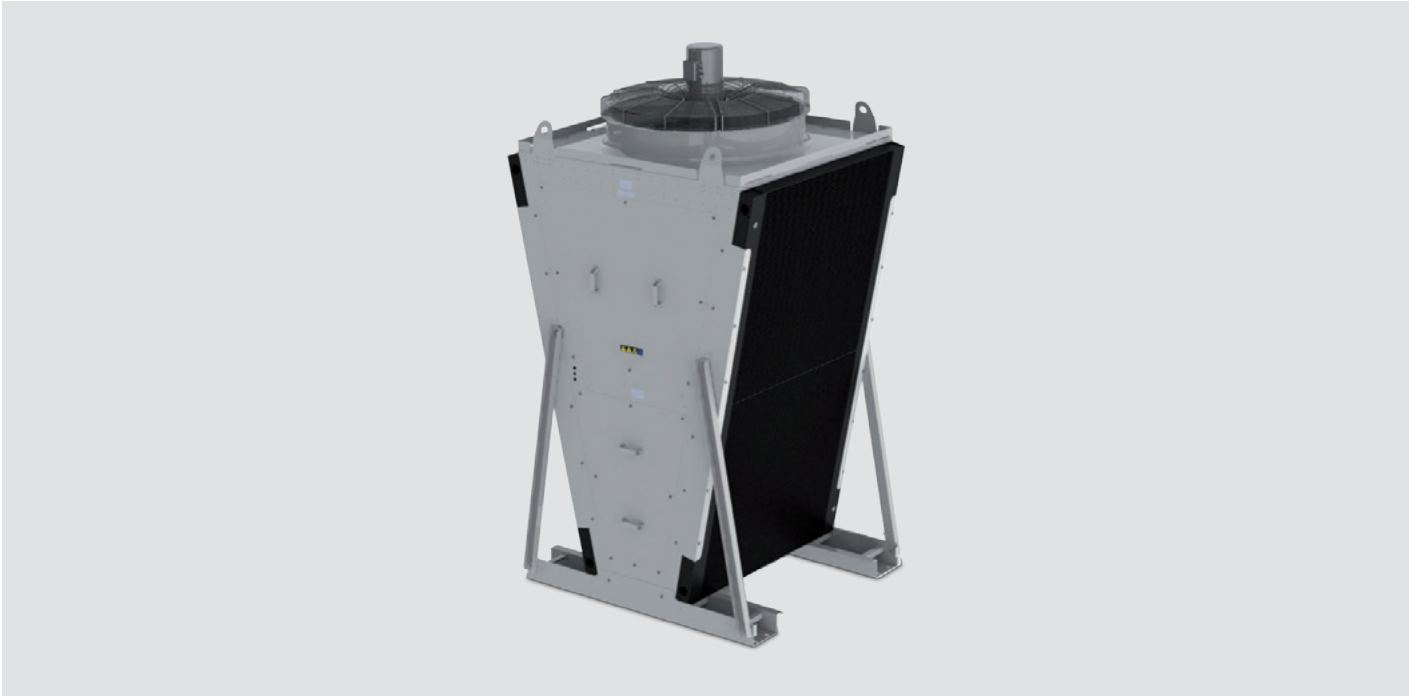

A range of products is available for Diesel and gas generators with an electrical power output of 40 kVA / 200 kVA / 300 kVA / 500 kVA / 800 kVA and up to 1,400 kVA.

Modularity of the cooling systems allows to expand the cooling capacity to any enhanced requirement.

AC-MS Compact Design

AC-MS compact coolers are the ideal choice for energy power applications that demand extremely high thermal capacity in limited space.

The overall dimensions of the coolers are compatible with the height limits of standard or high cube 20/40 ft ISO container. With electric motors for fan drives with electric power up to 22 kW with 2 and 4 poles and option for variable speed drive. The modular design allows vertical and horizontal air flow direction. Mounting position of the cooling system in both vertical and horizontal position meets any specific installation requirement.

Horizontal air flow direction

Stacked cooler – Vertical lay-out



Twin/Stacked cooler – Vertical lay-out



Vertical air flow direction

Single Table cooler – Horizontal lay-out



Modular cooler – Horizontal lay-out

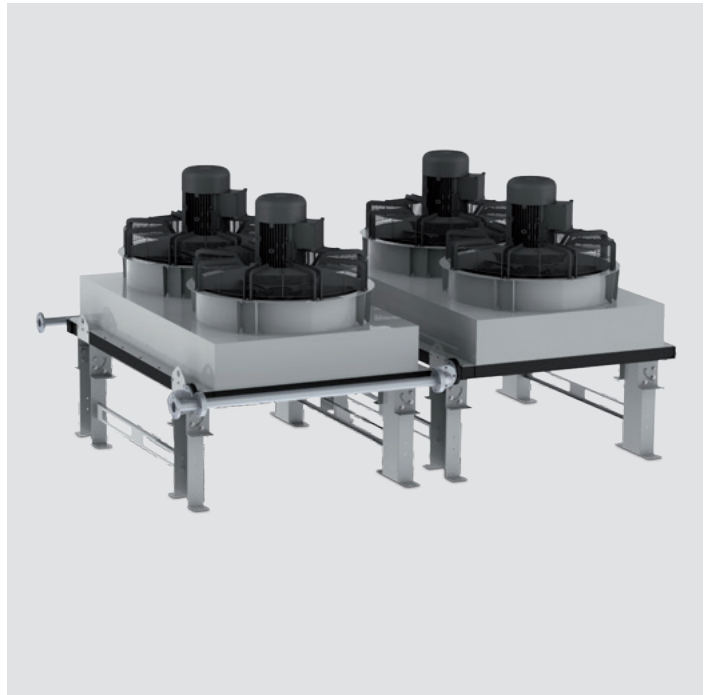

AC-MS Heavy Duty

AC-MS Heavy Duty systems are designed to match the highest level of performances and reliability.

The radiator core is available with various core thicknesses, assembled in a structural steel frame suitable for outdoor installation. Those coolers integrate a bunded tank required for leakage and for safe maintenance operation.

AC-MS coolers are available in several standard models that may be configured with options such as acoustic louvers, hydraulic and electrical control box, air flow inlet and outlet conveyor.

All the parts are easily accessible for cleaning, inspections and testing procedures.

Typical applications are those in the energy market segment as well as for gas turbine lubrication oil bearing or general industrial application.

Single module – open top



Modular system

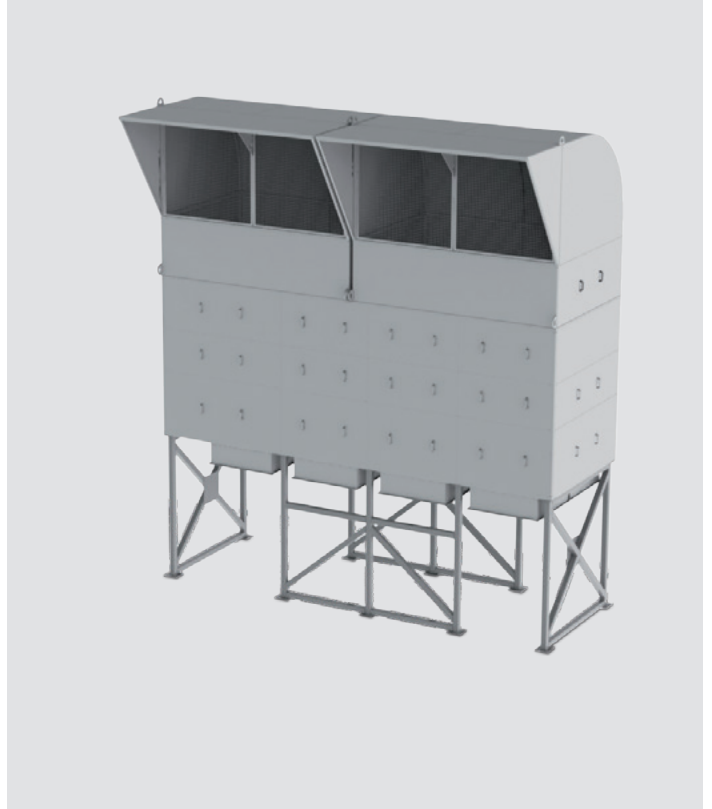

AC-MS Installation Examples

AC-MS Compact – HT/LT Circuit

3,200 kVA Diesel engine
– Emergency operation



AC-MS Compact – Modular table coolers

Cooling systems for gas compressor power station
Baseload and standby units



AC-MS Low Noise

Variable speed fans – 800 kVA Diesel engine
Jacket water and charge air cooler engine circuits

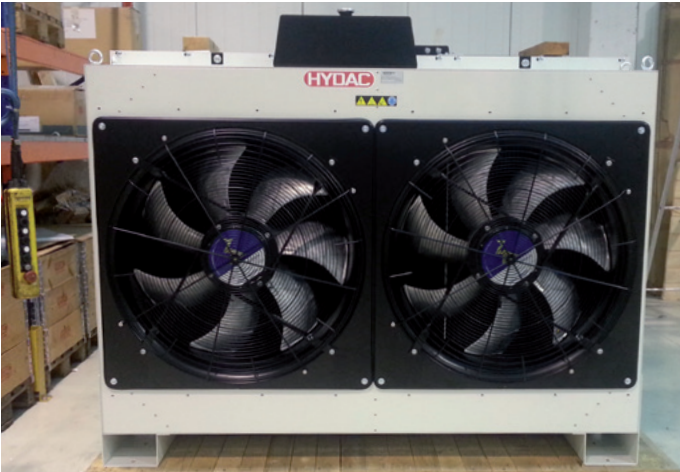

AC-MS Heavy Duty

Cooling system for air compressor



AC-MS Options Available

- Expansion / Filling tank
- ISO flanged / Victaulic hydraulic connection
- Fluid temperature and level sensors
- Safety switches for electric motors maintenance
- CPL version (Corrosion Protection Level)
- ATEX version
- Customized solutions
- Fan systems for engine room temperature control with AC/DC motors and brushless option with PWM speed control

Note

The information in this brochure relates to the operating conditions. For applications and operating conditions not described, please contact the relevant technical department. Subject to technical modifications.



HYDAC COOLING GMBH

INTERNATIONAL

Industriegebiet
66280 Sulzbach/Saar
Germany

Tel.: +49 6897 509-01
Fax: +49 6897 509-454

E-mail: cooling@hydac.com
Internet: www.hydac.com

**HYDAC AG
Mezzovico Branch**

Via Sceresca, Zona Industriale 3
6805 Mezzovico
Switzerland

Tel.: +41 91 9355-700
Fax: +41 91 9355-701

E-mail: info@hydac.ch
Internet: www.hydac.com

Air Cooler Industry / Mobile AC-LN / ACA-LN / ACAF-LN / AC-LNH ATEX



Certified to ATEX EU Directives

General

For applications in potentially explosive areas are the air cooler series AC-LN (without pump and filter) and AC-LNH also available with ATEX certification.

In order to prevent serious personal injury and damage to equipment, the highest possible level of safety must be achieved in such potentially explosive locations. Numerous requirements in terms of laws, regulations, directives and standards have been issued worldwide to enhance the level of safety.

In the context of globalisation, these have been combined, at least in Europe, into harmonised directives for explosion protection.

In the EU, the so-called ATEX directive regulates explosion protection (ATEX is the abbreviation of ATMosphaère Explosible). This directive of the European Parliament and the Council (RL 94/9/EG) which has been in force since 1994 regulates "the alignment of laws of the member states relating to equipment and protection systems specifically for use in potentially explosive locations".

The target group includes amongst others the manufacturers of equipment. Following a revision in July 2003, all new equipment must be realised according to this directive. This directive applies to areas where potentially explosive gases and dust are present and also in mining.

Product Features

Available for operating in potentially explosive areas are air coolers with AC motor (AC-LN, ACA-LN, ACAF-LN) and air coolers with hydraulic motor (AC-LNH). The certification applies for a frequency of 50 Hz and 60 Hz versions.

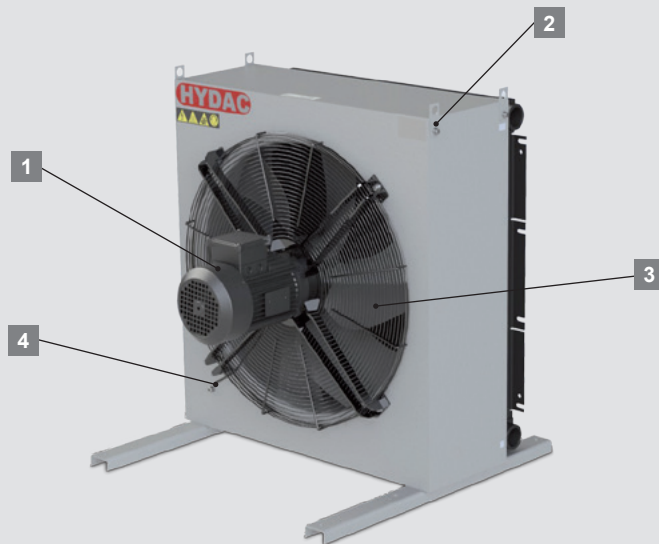

The components are developed especially for use in potentially explosive areas:

- 1 ATEX certified motor (protected against gas and dust)
- 2 Stainless steel screws with special washer earthing
- 3 Antistatic fan with plastic fan blades
- 4 All components earthed / Cable earthing between motor screw and housing



Certification



II 2G EX de IIC T4
II 2GD EX de IIC T4

II **Device group:**
I = Mining
II = all other explosive areas (non-mining)

2G / 2GD **Category:**
2 = present in normal operation
Explosive atmosphere:
G = gas
D = dust

Ex **Explosion protection**

de **Type of protection:**
de = fireproof with increased safety

IIC **Explosive group for gas:**
IIC = most dangerous class (e.g. hydrogen)

T4 **Temperature classes:**
T4 = 135 °C

Note

The information in this brochure relates to the operating conditions. For applications and operating conditions not described, please contact the relevant technical department. Subject to technical modifications.

HYDAC

HYDAC COOLING GMBH

INTERNATIONAL

Industriegebiet
66280 Sulzbach/Saar
Germany

Tel.: +49 6897 509-01
Fax: +49 6897 509-454

E-mail: cooling@hydac.com
Internet: www.hydac.com

HYDAC AG
Mezzovico Branch

Via Sceresca, Zona Industriale 3
6805 Mezzovico
Switzerland

Tel.: +41 91 9355-700
Fax: +41 91 9355-701

E-mail: info@hydac.ch
Internet: www.hydac.com



Air Cooler Industry AC-LN / ACA-LN / ACAF-LN 2-14 Corrosion Protection Levels (CPL)

General

The AC-LN series is also available to work in aggressive environments with high corrosive potential. The design is a result of our research and developments during years of experience.

The protection levels are verified in neutral salt spray tests following EN ISO 9227.

Quality and performance are guaranteed in every condition.

Product Features

Protection Level	Standard	Medium	High
System code	–	CPL1	CPL2
Ambient	C2-H*	C3-H*	C4-H*
Description	Atmosphere with low level of pollution. Places where condensation may occur.	Atmospheres with moderate pollution and humidity. Coastal areas with low salinity.	Industrial areas and coastal areas with moderate salinity.

* Following EN ISO 12944

C5-H or configurations according to other standards can be supplied on request. ATEX certification is available on request.

For all other standard air cooler series, corrosion protection levels on request.

Application Field

For all industrial applications, indoor and outdoor applications in an aggressive environment where a high level of corrosion protection is requested. e.g.

- cranes
- harbour
- marine platforms
- ships
- chemical plants
- agricultural sites

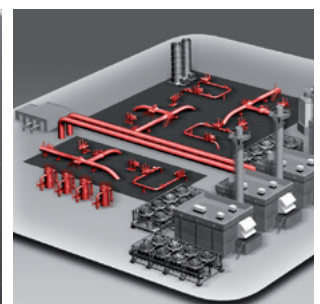

Model Type

AC-LN10L - - CPL2

Corrosion Protection Level

n/a = Standard

CPL1 = Medium protection level

CPL2 = High protection level

CPLS = Special protection level

For CPLS version refer to the technical department.

Note

The information in this brochure relates to the operating conditions.

For applications and operating conditions not described, please contact the relevant technical department.

Subject to technical modifications.



HYDAC COOLING GMBH

INTERNATIONAL

Industriegebiet
66280 Sulzbach/Saar
Germany

Tel.: +49 6897 509-01
Fax: +49 6897 509-454

E-mail: cooling@hydac.com
Internet: www.hydac.com

**HYDAC AG
Mezzovico Branch**

Via Sceresca, Zona Industriale 3
6805 Mezzovico
Switzerland

Tel.: +41 91 9355-700
Fax: +41 91 9355-701

E-mail: info@hydac.ch
Internet: www.hydac.com



Air Cooler Mobile OK-ELH 2-7 with hydraulic motor

Symbol

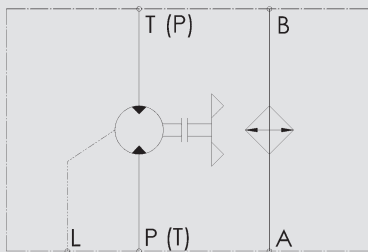

General

The OK-ELH air cooler series is designed specifically for mobile hydraulic applications where high performance and efficiency are required and physical size is minimized to allow easy installation.

Product Features

These coolers use a combination of high performance cooling elements and hydraulic motors to give long trouble free operation in arduous mobile hydraulic applications.

- Compact, efficient, high performance
- Cooling range 4-55 kW
- Hydraulic Motors from 6.3 to 22 cm³/r

Application Field

For transmission cooling and hydraulic systems in all mobile machines and vehicles, such as

- Mobile cranes
- Concrete mixers and pump trucks
- Road paving machines
- Construction machines (excavators, wheel loaders)
- Agricultural machines
- Municipal machines

Operation Data

Fluids	<ul style="list-style-type: none"> ● Oils (mineral oils, synthetic oils, high viscosity oils, biological oils, phosphate ester) ● Water-glycol (cooling fluids)
Viscosity	2,000 mm ² /s (standard)
Temperature range	<ul style="list-style-type: none"> ● Minimum / maximum ambient temperature: -20 °C bis +40 °C (standard) ● Minimum / maximum temperature of the medium: +20 °C to +130 °C <p>Please contact the technical sales department in the event of deviating temperatures.</p> <p>Notice! Fan at max. speed (max. volume of air) must be avoided when operating a cooler at which the temperature difference between the medium inlet at the cooler and the ambient temperature can be greater than 50 °C. Quick changes in the temperature of the cooling element material can lead to a significant reduction in service life or to direct damage of the cooling element due to thermal shock. Please contact the technical sales department to receive information about controlled fan drives.</p>
Pressure resistance of the cooling element	<ul style="list-style-type: none"> ● Dynamic operating pressure: 16 bar ● Static operating pressure: 21 bar
Fan	<p>Axial fan in suction version (standard) Axial fan in pushing version on request (note: approx. 10 % less cooling capacity)</p>
Motor*	<ul style="list-style-type: none"> ● Hydraulic motor reversible with drain port ● max. outlet side pressure: 120 bar ● max. drain pressure: 2 bar ● max. peak pressure: 6.3/14 cm³/U = 300 bar, 22 cm³/U = 200 bar ● Operating fluid: Mineral oil to DIN 51524/25 DIN 51511 Fluid viscosity range: 10 - 600 mm²/s (recommended 30 - 45 mm²/s) Fluid temperature range: up to 90 °C Filtration : ISO/DIS 4406, Code 19/16, β₂₅ > 75
Noise levels	<p>See technical data The noise levels are only reference values as the acoustic properties of a room, connections and reflection have an effect on the noise level.</p>
Accessories	<ul style="list-style-type: none"> ● Integrated pressure bypass valve (IBP) or integrated thermal pressure bypass valve (IBT) (cannot be retrofitted, also see options) ● Thermostats ● Air filter grid or air filter mat ● Vibration damper

* The motor oil flow Q can be calculated at nominal motor oil operating pressure as follows:

$$Q = \frac{V_g \times n}{10^3 \times \eta_{vol}} \quad [l/min]$$

V_g = motor displacement [cm³/U]

n = fan speed [rpm]

η_{vol} = volumetric efficiency = 90 % at motor oil operating pressure of 150 bar

(Calculation also in simulation software "KULI" possible)

Options

Integrated pressure bypass valve (IBP) / Integrated thermal pressure bypass valve (IBT)

The bypass channel is integrated in the cooling element. If a particular pressure is exceeded, the IBP opens the bypass channel, thereby protecting the cooling element from too high a pressure. Furthermore, the IBT only opens the cooling element path once a particular temperature has been reached.

ATEX

The OK-ELH is also available for operation in gas and dust explosive areas.

Corrosion protection CPL

The CPL version (corrosion protection level) is for aggressive ambient conditions, such as industrial atmospheres, high humidity or high salt content, which place great demands on the corrosion resistance and robustness of the materials used.

Thermal bypass Hydraulic motor / variable speed

The thermo valve is a pre-controlled pressure valve with temperature-dependent pressure control and is mounted on the hydraulic motor in place of the existing cover plate.

The pressure setting of the valve automatically changes dependent on the temperature and thus controls the motor speed. In addition to the actual temperature-controlled pressure setting, a mechanical maximum pressure control and a recharging valve are fitted as a non-return valve.

The switching temperature values can be set from 40 to 70 °C and the pressure can be controlled up to 100 °C: please contact our sales for the dimensioning of the thermo-bypass.

All the standard hydraulic motors can be used with the thermo-bypass. The minimum oil pressure at which the thermo control starts to work is 8 bar, i. e. a maximum residual power consumption corresponding to 8 bars is to be foreseen also in by-pass phase.

Dimension

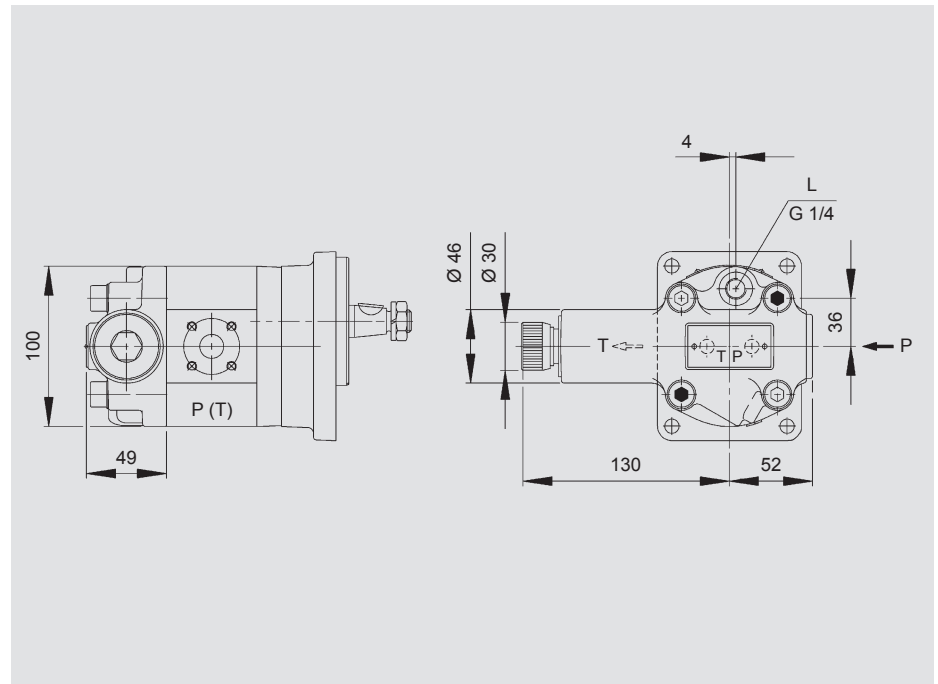

Symbol Thermal bypass

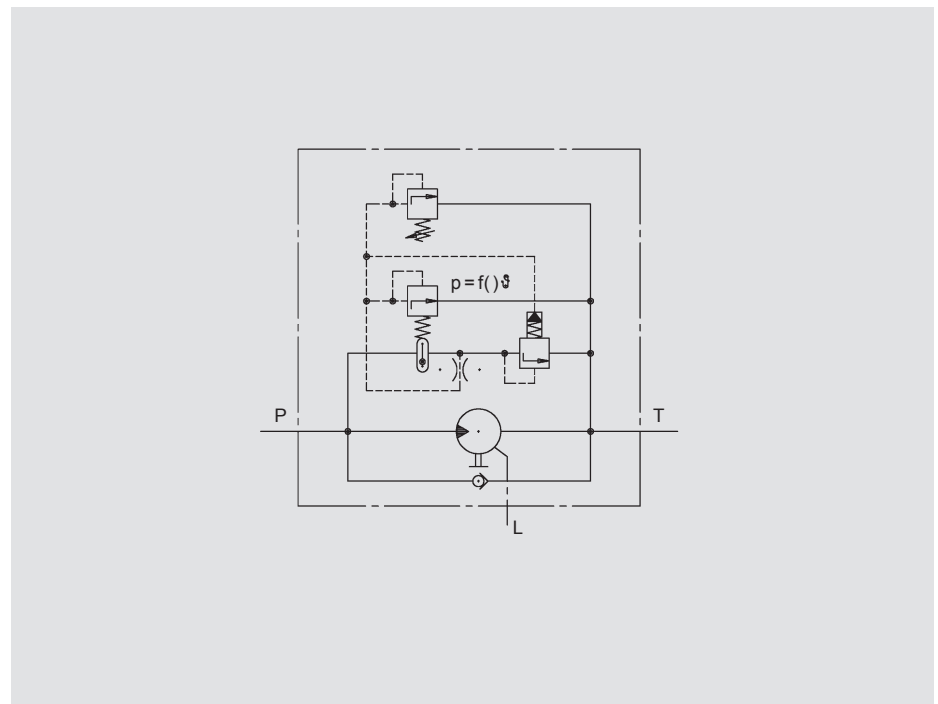

Design

OK-ELH 2-4

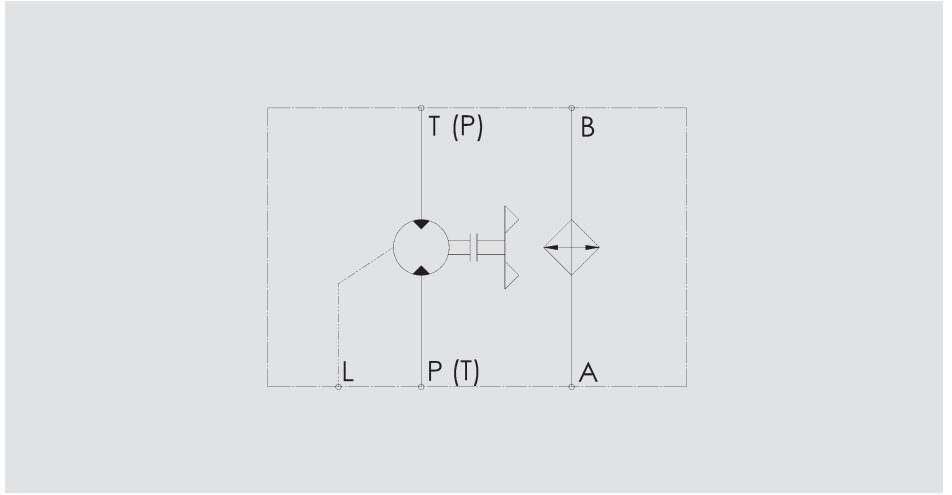
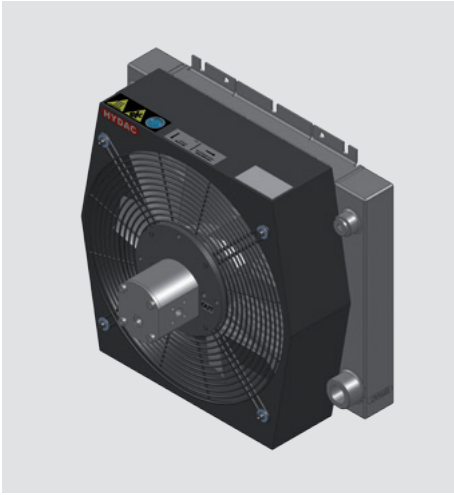

Air cooler with

- 1 Hydraulic motor
- 2 Finger grid
- 3 Fan housing
- 4 Axial fan
- 5 Heat exchanger

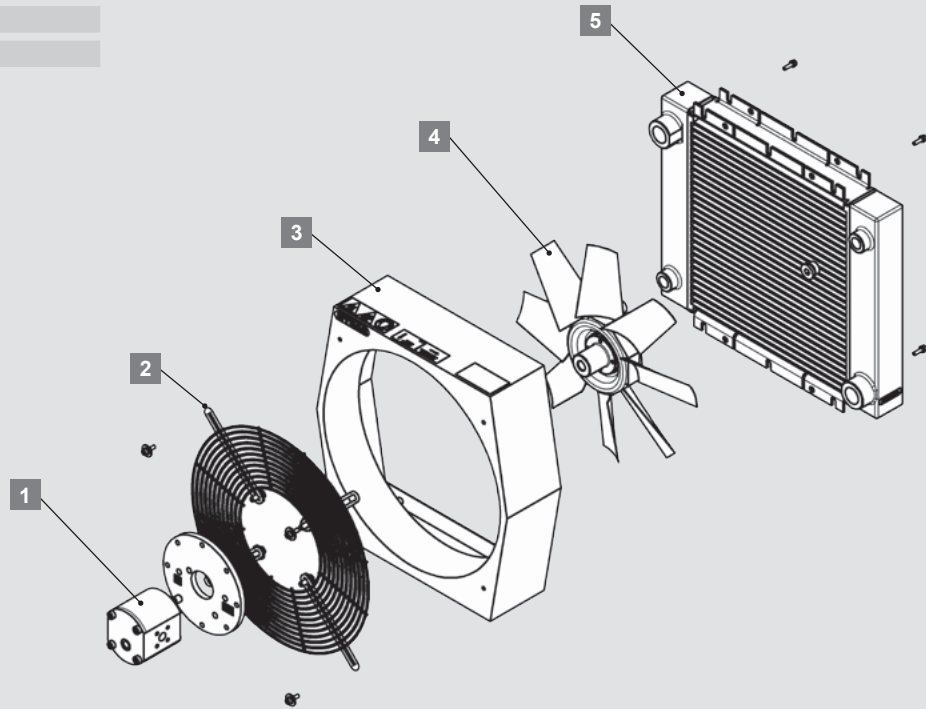

Design

OK-ELH 5

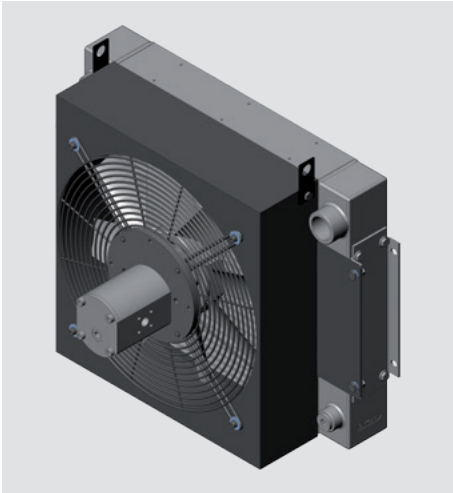

OK-ELH 6

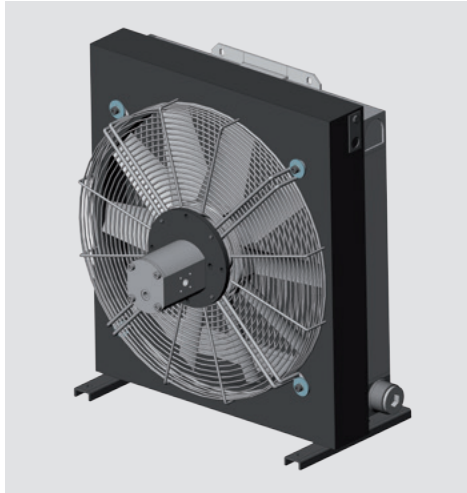

OK-ELH 7

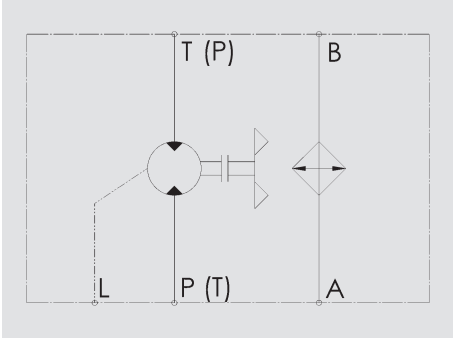
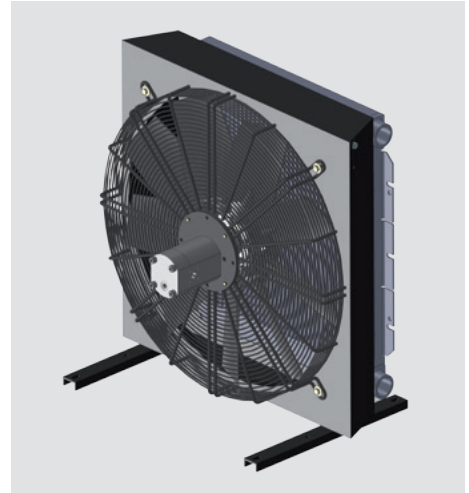

OK-ELH 5

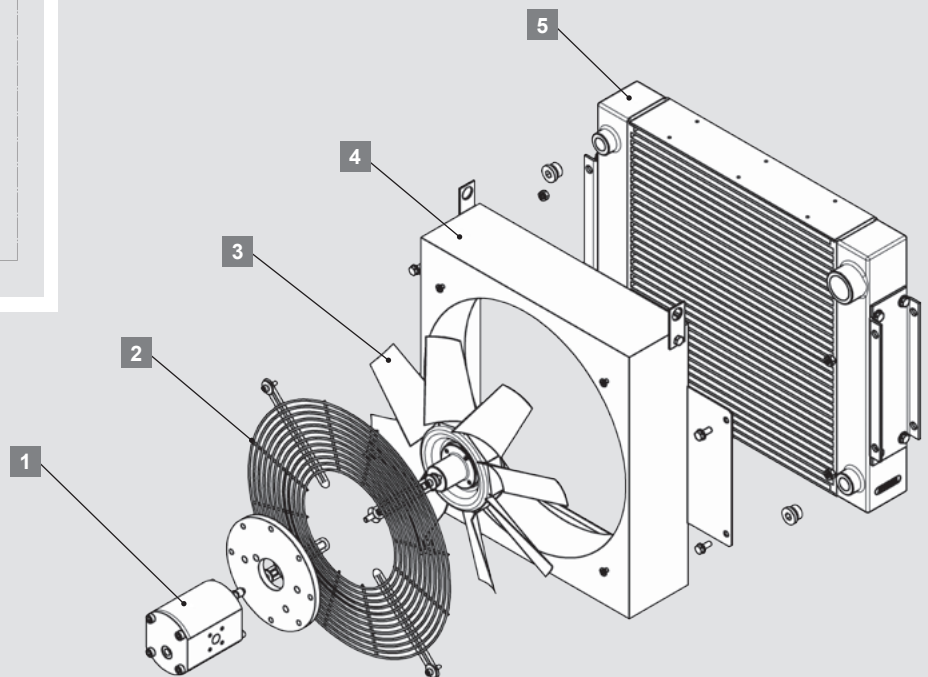

Air cooler with

- 1 Hydraulic motor
- 2 Finger grid
- 3 Axial fan
- 4 Fan housing
- 5 Heat exchanger

Air cooler with

- 1 Hydraulic motor
- 2 Finger grid
- 3 Axial fan
- 4 Fan housing
- 5 Heat exchanger

OK-ELH 6-7

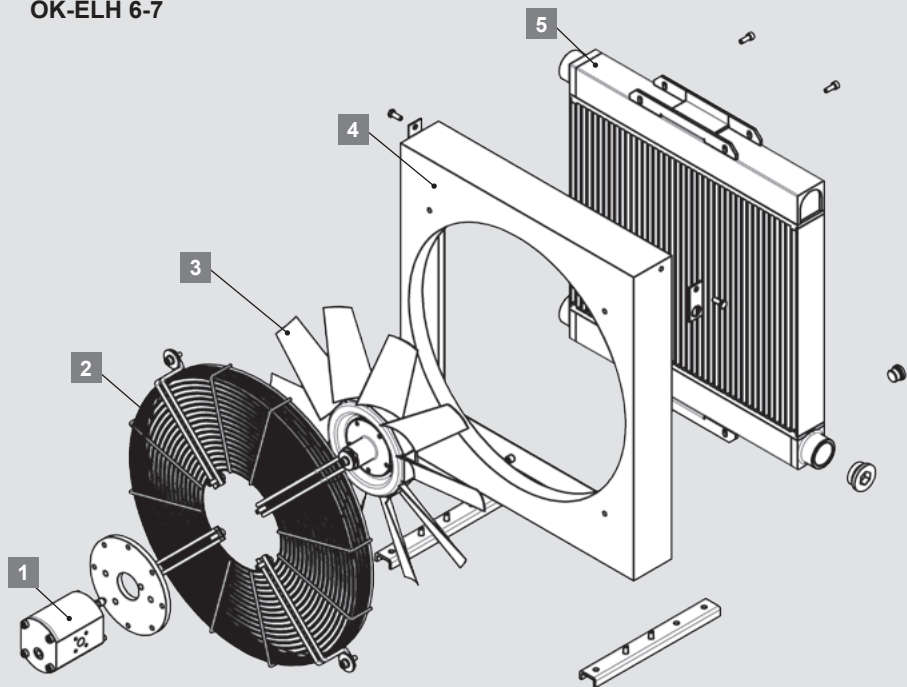

Technical Data

OK-ELH 2-7

Type of cooler	P/N	Motor displacement [cm ³ /r]	Operating speed range [rpm]	Fluid flow [l/min] ¹⁾	Air flow [m ³ /h] ¹⁾	Continuous motor operating pressure [bar]	Required pressure for max. speed [bar] ²⁾	Motor oil flow at 1,500 rpm [l/min]	Noise level at 1,000 rpm [dB(A)] (at 1 m distance)	Volume [l] ³⁾	Weight [kg] ⁴⁾
OK-ELH 2	3118399	6.3	1,500 - 3,000	180	420	250	20	10.5	69	2.0	11
OK-ELH 2	3118400	14.0	1,500 - 3,000	180	420	250	20	23.0	69	2.0	11
OK-ELH 3	3103131	6.3	1,500 - 3,000	250	740	250	20	10.5	69	2.2	13
OK-ELH 3	3103134	14.0	1,500 - 3,000	250	740	250	20	23.0	69	2.2	13
OK-ELH 3	3103523	22.0	1,500 - 3,000	250	740	150	20	36.6	69	2.2	13
OK-ELH 4	3106813	6.3	1,500 - 3,000	250	1,500	250	50	10.5	70	3.0	18
OK-ELH 4	3106816	14.0	1,500 - 3,000	250	1,500	250	30	23.0	70	3.0	18
OK-ELH 4	3106817	22.0	1,500 - 3,000	250	1,500	150	20	36.6	70	3.0	18
OK-ELH 5	3098892	6.3	1,500 - 3,000	250	1,700	250	70	10.5	70	5.2	24
OK-ELH 5	3103135	14.0	1,500 - 3,000	250	1,700	250	30	23.0	70	5.2	24
OK-ELH 5	3107149	22.0	1,500 - 3,000	250	1,700	150	20	36.6	70	5.2	24
OK-ELH 6	3128565	6.3	1,000 - 3,000	250	3,300	250	150	10.5	72	4.6	43
OK-ELH 6	3128566	14.0	1,000 - 3,000	250	3,300	250	70	23.0	72	4.6	43
OK-ELH 6	3128567	22.0	1,000 - 3,000	250	3,300	150	50	36.6	72	4.6	43
OK-ELH 7	3189345	14.0	1,000 - 2,000	250	7,800	250	220	23.0	77	5.2	50
OK-ELH 7	3189359	22.0	1,000 - 2,000	250	7,800	150	140	36.6	77	5.2	50

¹⁾ Max. flow rate at 1,500 1/min

²⁾ at 34 mm²/s

⁴⁾ Fluid in cooling element

³⁾ Unfilled

Cooling Capacity and Pressure Difference Δp

OK-ELH 2-7

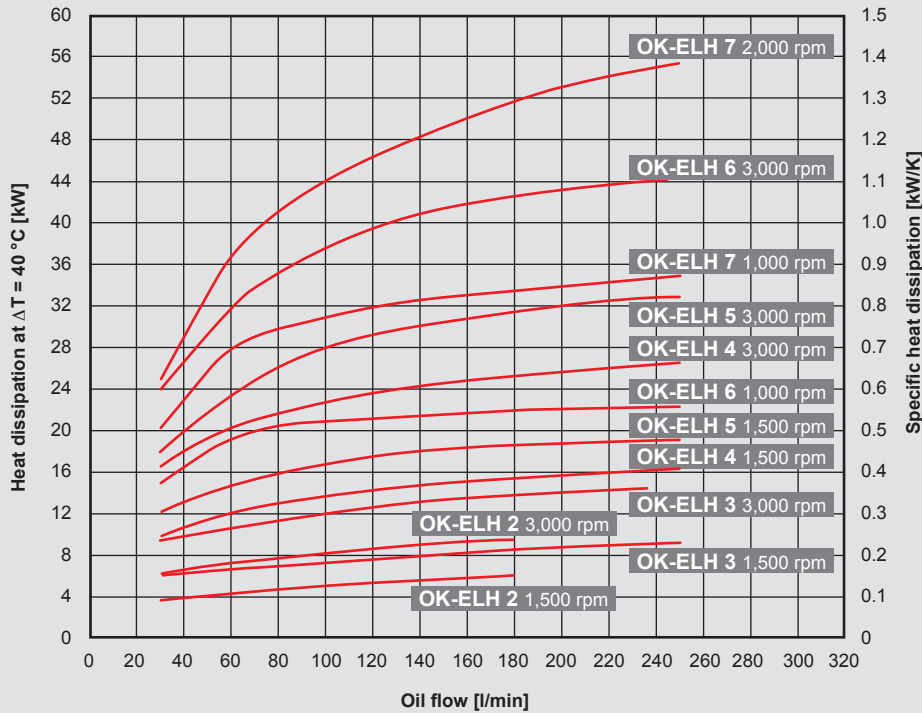

Tolerance: $\pm 5\%$

Cooling capacity:

Dependent on the oil flow rate and the temperature difference ΔT between oil inlet and air inlet.

Note:

The values are measured at $\Delta T = 40^\circ\text{C}$. For smaller ΔT values, the values can change. You can also use our cooler calculation software for designing. Please contact our technical sales department.

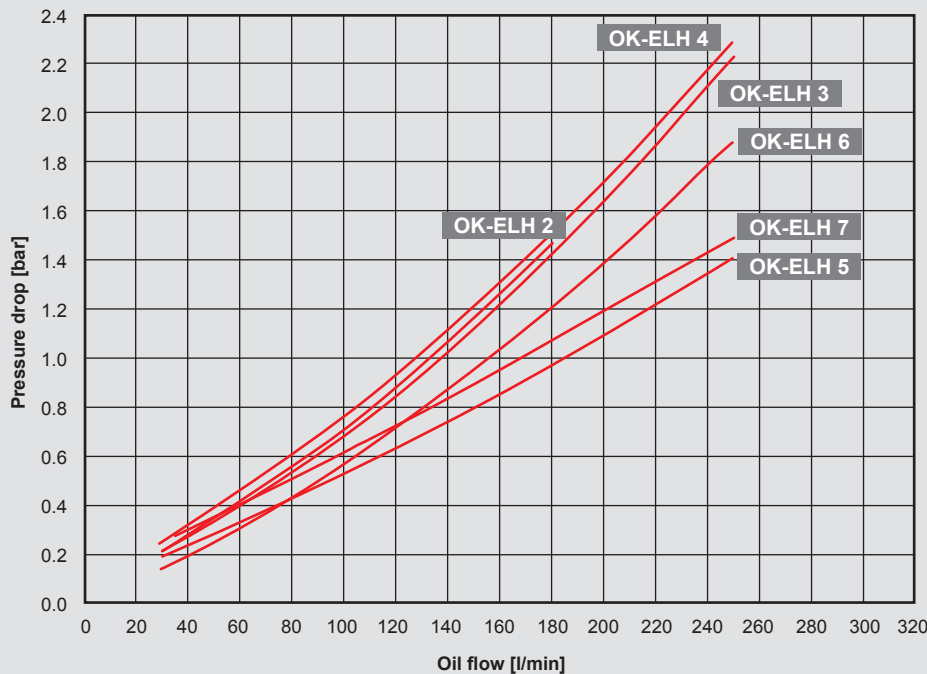

measured at $30\text{ mm}^2/\text{s}$

Tolerance: $\pm 5\%$

Pressure difference Δp

For other viscosities, the pressure loss must be multiplied by the conversion factor K:

Viscosity (mm^2/s)	10	15	22	30	46	68	100	150
Factor K	0.35	0.5	0.75	1.0	1.4	1.9	2.5	3.5

Model Type

OK-ELH - 2 - 1.0 - H6.3TB - 1 - S - AITF60

Cooler type

OK-ELH = Oil-Air cooler

Size

2-7 = Size

Revision

Motor displacement

H6.3 = 6.3 cm³/r

H14 = 14 cm³/r

H22 = 22 cm³/r

H..TB = hydraulic motor with thermal bypass

Color

1 = RAL 9005 (standard)

Other colors on request.

Air flow direction

S = Suction (standard)

D = Blowing (on request)

Accessories

IBP = Heat exchanger with integrated bypass valve

IBT = Heat exchanger with integrated thermo-bypass valve

AITF = Thermostat (fixed)

FU = Feet

For all possible accessories, like vibration absorber, air filter grid or air filter mat please refer to brochure Accessories for air coolers.

Dimensions

OK-ELH 2-4

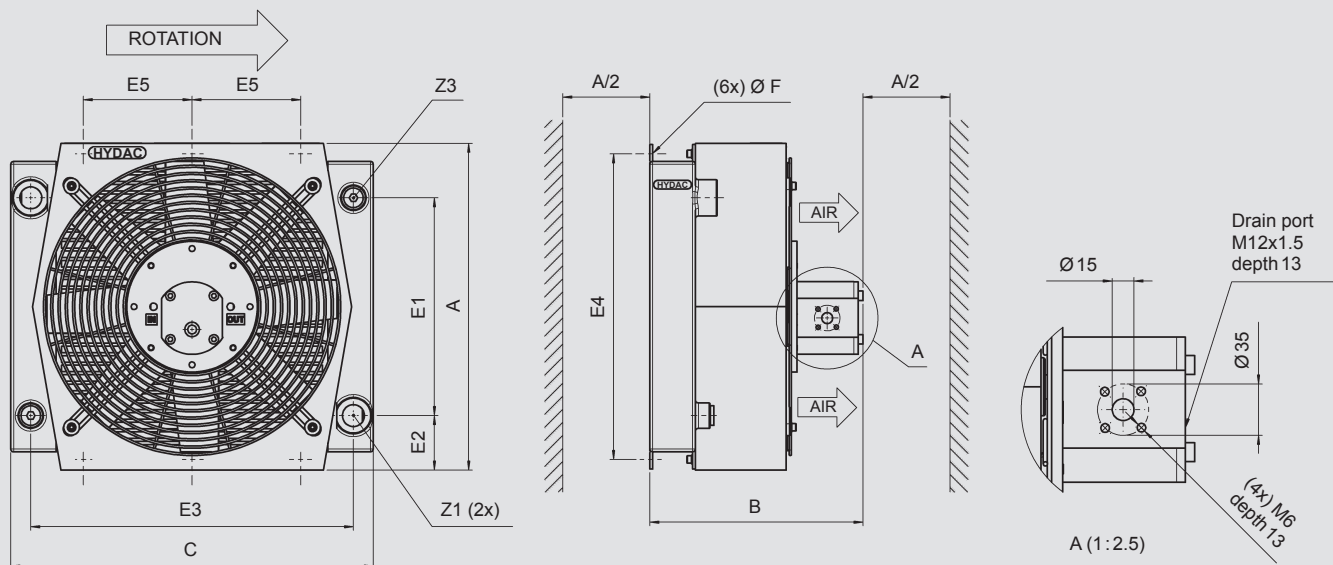

[mm]	A ±5	B ±10 6.3 cc	B ±10 14 cc	B ±10 22 cc	C ±5	E1 ±5	E2 ±5	E3 ±5	E4 ±2	E5 ±2	F ø/slot	Z1	Z3
OK-ELH 2	313	270	283	283	384	199	57	324	288	80	14x10	G1"	M22x1.5
OK-ELH 3	356	279	292	292	420	230	63	370	329	100	14x10	G1"	M22x1.5 ¹⁾
OK-ELH 4	450	294	306	306	500	300	80	445	421	150	19x10	G1"	M22x1.5 ²⁾

¹⁾ OK-ELH 3 and OK-ELH 4 have two connections M22x1.5.

OK-ELH 5

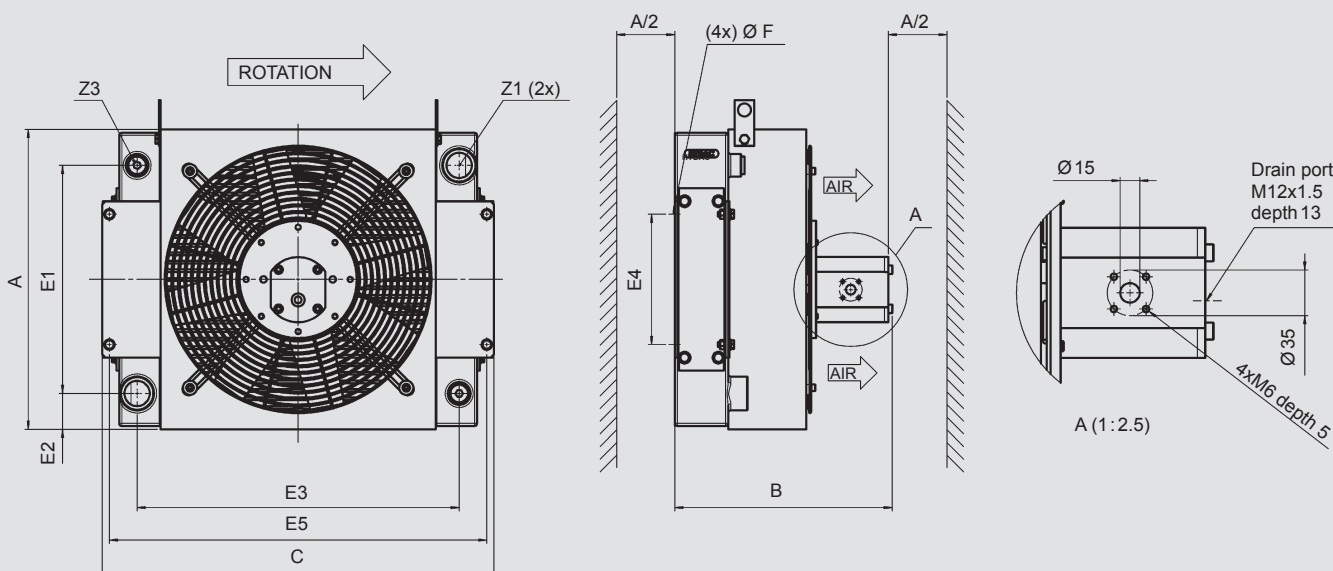

[mm]	A ±5	B ±10 6.3 cc	B ±10 14 cc	B ±10 22 cc	C ±5	E1 ±5	E2 ±5	E3 ±5	E4 ±5	E5 ±5	F ø/slot	Z1	Z3
OK-ELH 5	460	311	323	338	602	350	55	495	200 ²⁾	580 ²⁾	12	G1-1/4"	M22x1.5 ²⁾

¹⁾ The cooling element has two connections M22x1.5.

²⁾ OK-ELH 5 has the front fixing holes in the lateral sides.

OK-ELH 6

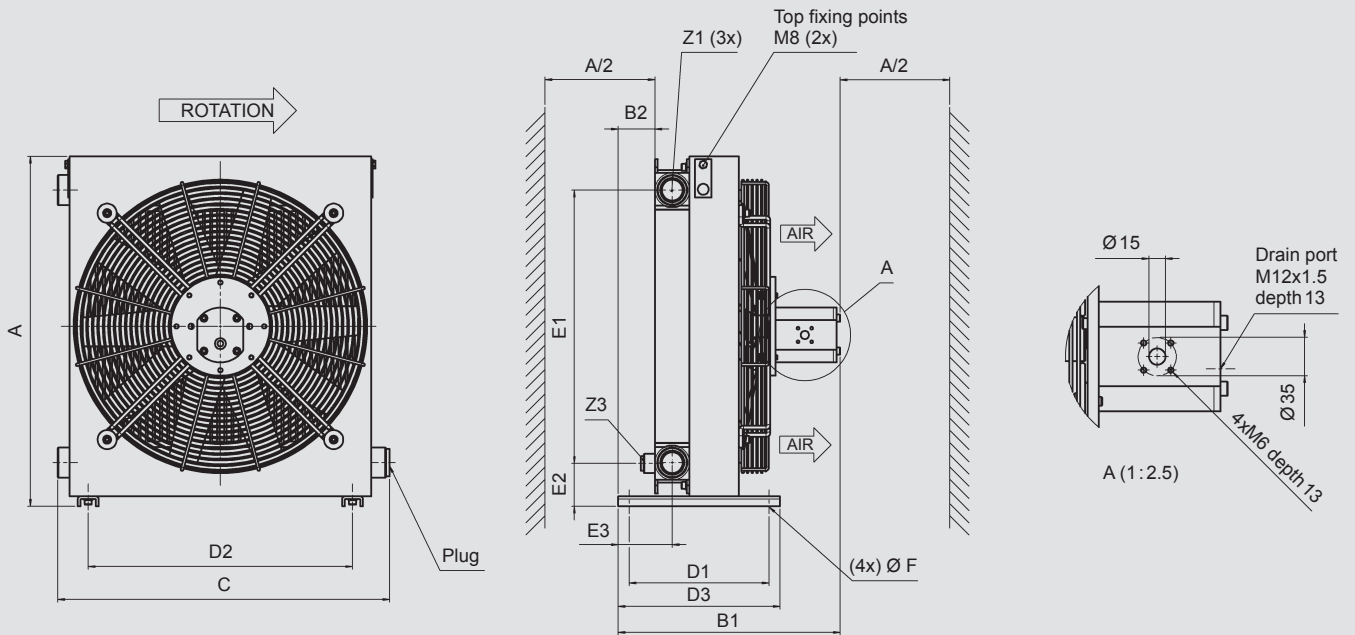

[mm]	A ±5	B1 ±10 6.3 cc	B1 ±10 14 cc	B1 ±10 22 cc	B2 ±5	C ±5	D1 ±2	D2 ±2	D3 ±2	E1 ±5	E2 ±5	E3 ±5	F ø/slot	Z1	Z3
OK-ELH 6	638	378	391	405	67	598	255	482	295	497	80	98	9	G1-1/4"	M22x1.5

OK-ELH 7

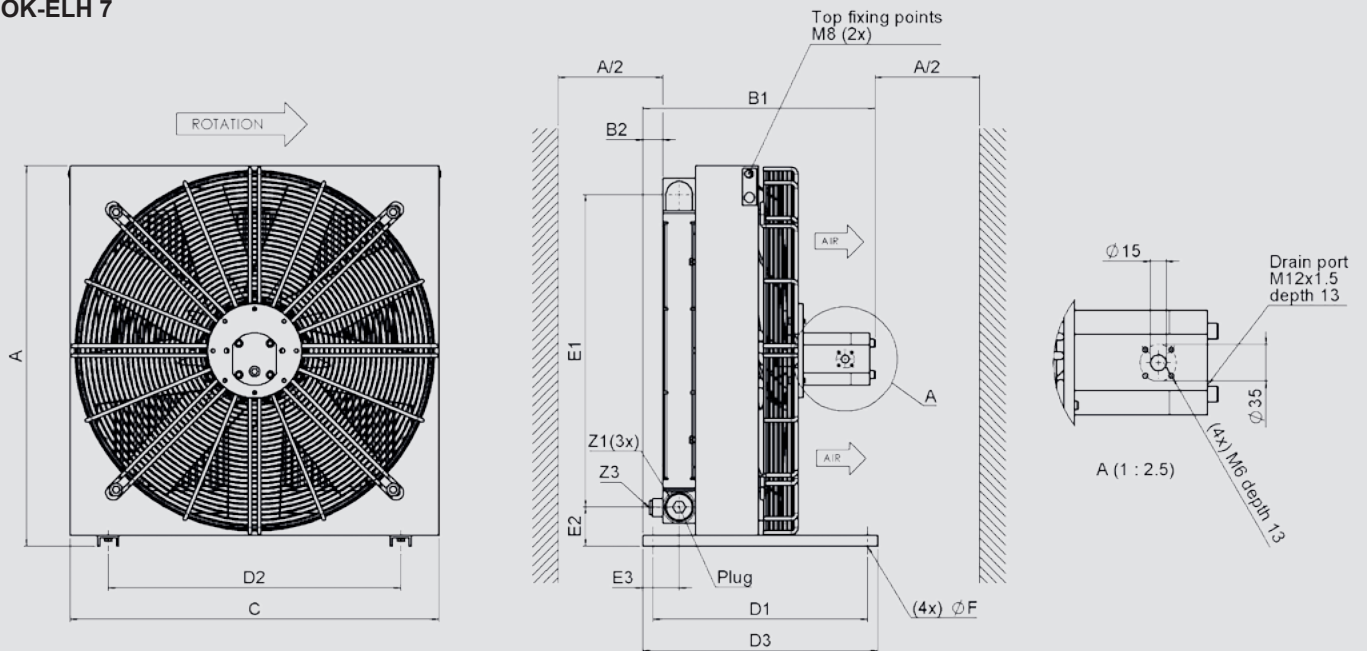

[mm]	A ±5	B1 ±10 6.3 cc	B1 ±10 14 cc	B1 ±10 22 cc	B2 ±5	C ±5	D1 ±2	D2 ±2	D3 ±2	E1 ±5	E2 ±5	E3 ±5	F ø/slot	Z1	Z3
OK-ELH 7	726	–	444	459	42	706	410	560	450	597	75	73	9x20	G1-1/4"	M22x1.5

Note:

We recommend maintaining a minimum distance to ensure an unimpeded air inlet and air outlet. This is half the height of the cooling element (A/2). Anything below the minimum distance can influence the cooling capacity and the noise emissions.

Note

The information in this brochure relates to the operating conditions.

For applications and operating conditions not described, please contact the relevant technical department.

Subject to technical modifications.



HYDAC COOLING GMBH

INTERNATIONAL

Industriegebiet
66280 Sulzbach/Saar
Germany

Tel.: +49 6897 509-01
Fax: +49 6897 509-454

E-mail: cooling@hydac.com
Internet: www.hydac.com

**HYDAC AG
Mezzovico Branch**

Via Sceresca, Zona Industriale 3
6805 Mezzovico
Switzerland

Tel.: +41 91 9355-700
Fax: +41 91 9355-701

E-mail: info@hydac.ch
Internet: www.hydac.com



Air Cooler Mobile AC-LNH 8-14 with hydraulic motor

Symbol

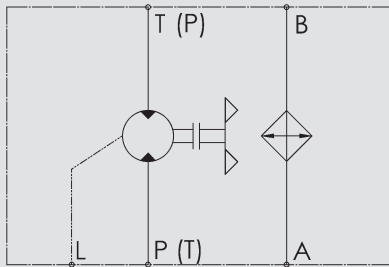

General

The AC-LNH air cooler series is designed specifically for mobile hydraulic systems where high performance and efficiency are required and physical size must be minimized to allow easy installation.

Product Features

AC-LNH coolers use a combination of high performance, pressure-resistant cooling elements and hydraulic drive motors in order to ensure long, trouble-free operation of hydraulic systems in the mobile sector.

- Compact, efficient, high performance
- Cooling range 20 – 290 kW
- Hydraulic motors from 6.3 to 22 cm³/rev

Application Field

Gearbox cooling and hydraulic systems in all mobile machines and vehicles, such as

- Mobile cranes
- Concrete mixers and pump trucks
- Road paving machines
- Construction machines (excavators, wheel loaders)
- Agricultural machines
- Municipal machines

Operation data

Fluids	<ul style="list-style-type: none"> ● Oils (mineral oils, synthetic oils, high viscosity oils, biological oils, phosphate ester) ● Water glycol (cooling fluid)
Viscosity	2,000 mm ² /s (standard)
Temperature range	<ul style="list-style-type: none"> ● Minimum / maximum ambient temperature: -20 °C to +40 °C (standard) ● Maximum temperature of the medium: +130 °C <p>Please contact the technical sales department in the event of deviating temperatures.</p> <p>Notice! Fan switching frequency at max. fan speed (max. volume of air) must be avoided when operating a cooler at which the temperature difference between the medium inlet at the cooler and the ambient temperature can be greater than +50 °C. Quick changes in the temperature of the cooling element material can lead to a significant reduction in service life or to direct damage of the cooling element due to thermal shock. Please contact the technical sales department to receive information about controlled fan drives.</p>
Pressure resistance of the cooling element	<ul style="list-style-type: none"> ● Dynamic operating pressure: 16 bar ● Static operating pressure: 21 bar
Fan	<p>Axial fan in suction version (standard) Axial fan in blowing version on request (note: approx. 10 % less cooling capacity)</p>
Motor*	<ul style="list-style-type: none"> ● Hydraulic motor ● Reversible direction of rotation ● max. outlet side pressure: 150 bar ● max. drain pressure: 5 bar ● max. operating pressure: 6.3/14 cm³/rev = 300 bar, 22 cm³/rev = 240 bar ● Operating fluid: Mineral oil to DIN 51524/25; DIN51511 ● Viscosity range: 12 – 750 mm²/s (recommended 12 – 100 mm²/s) ● Temperature range: up to +80 °C ● Filtration: ISO/DIS 4406, Class 19/17/14, β₁₀ ≥ 200 bar, Class 21/19/16, β₂₅ < 140 bar
Noise levels	<p>See Technical Data. The noise levels are only reference values as the acoustic properties of a room, connections and reflection have an effect on the noise level.</p>
Accessories	<ul style="list-style-type: none"> ● Integrated pressure bypass valve (IBP) or integrated thermal pressure bypass valve (IBT) (cannot be retrofitted, also see Options) ● Thermostats ● Air filter grid or air filter mat ● Vibration damper

* Calculation of the required oil volume:

$$Q = \frac{V_g \times n}{10^3 \times \eta_{vol}} \quad [l/min]$$

V_g = motor displacement [cm³/rev]

n = fan speed [rpm]

η_{vol} = volumetric efficiency = 90 % at operating pressure of 150 bar

(Calculation also possible in simulation software KULI)

Options

Integrated pressure bypass valve (IBP) / Integrated thermal pressure bypass valve (IBT)

The bypass channel is integrated in the cooling element. If a particular pressure is exceeded, the IBP opens the bypass channel, thereby protecting the cooling element from too high a pressure. Furthermore, the IBT only opens the cooling element path once a particular temperature has been reached.

ATEX

The AC-LNH is also available for operation in gas and dust explosive areas.

Corrosion protection CPL

The CPL version (Corrosion Protection Level) is suitable for aggressive ambient conditions, such as industrial atmospheres, high humidity or high salt content, which place great demands on the corrosion resistance and robustness of the materials used.

Thermal bypass hydraulic motor / variable speed

The thermal valve is a pilot-operated pressure relief valve with temperature-dependent pressure control and is mounted on the hydraulic motor instead of the provided end cap. The pressure setting of the valve automatically changes depending on the temperature and thus controls the motor speed. In addition to the actual temperature-controlled pressure setting, maximum pressure relief and a recharging valve are fitted as a bypass check valve. The setting temperature values can be from +40 °C to +70 °C and the pressure can be controlled up to +100 °C. Please contact us for the designing of the thermal valve. All hydraulic motors can be equipped with thermal bypass. The minimum oil pressure at which the valve starts to work is 8 bar, i.e. this must be taken into consideration for the rest of the operating pressure range of the motor.

Thermal bypass dimensions

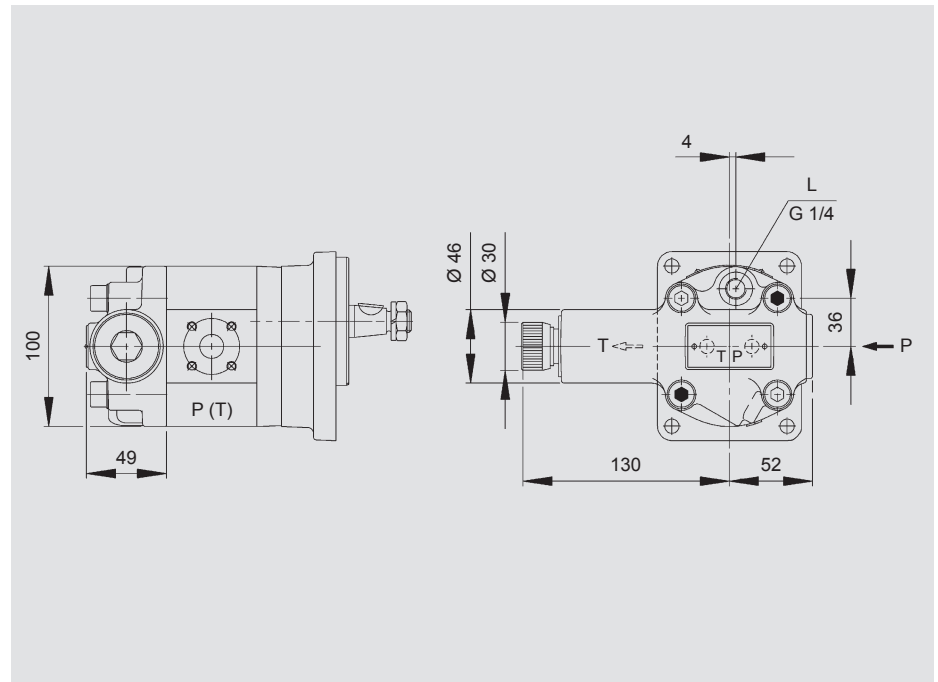

Thermal bypass symbol

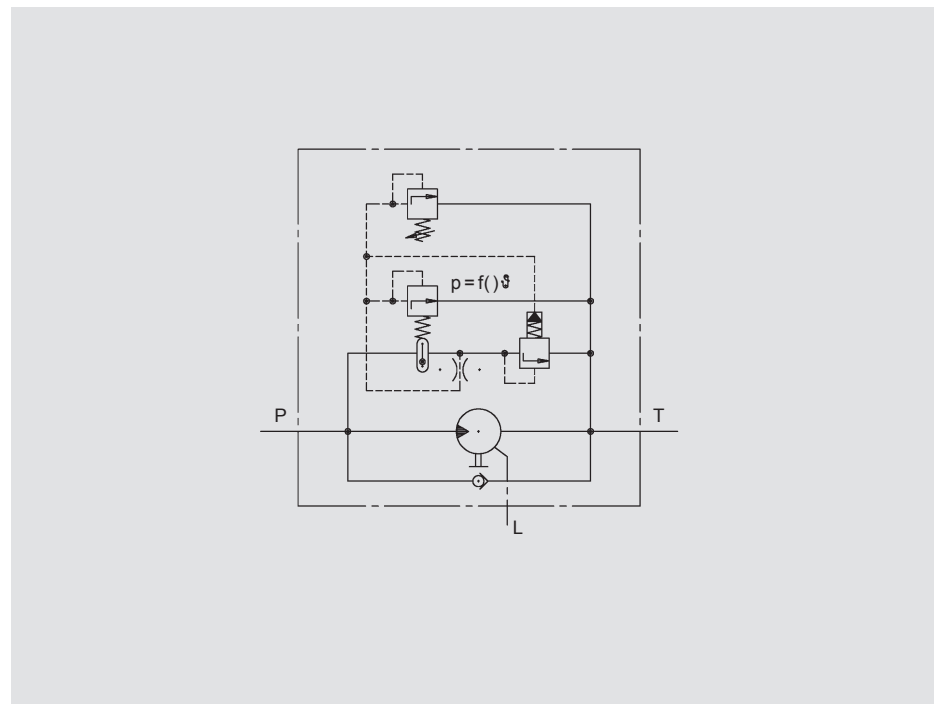

Design

AC-LNH 8-9

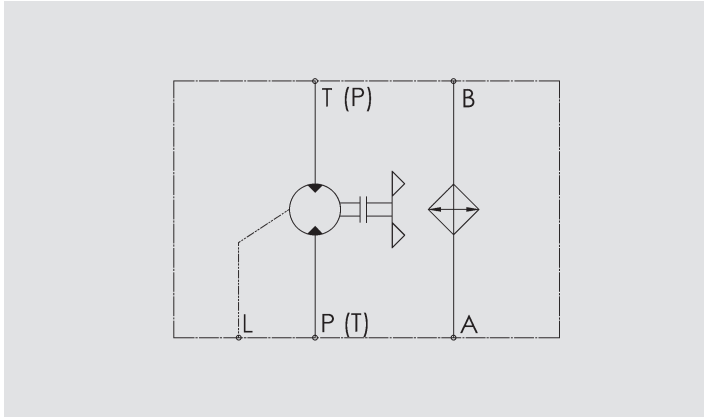
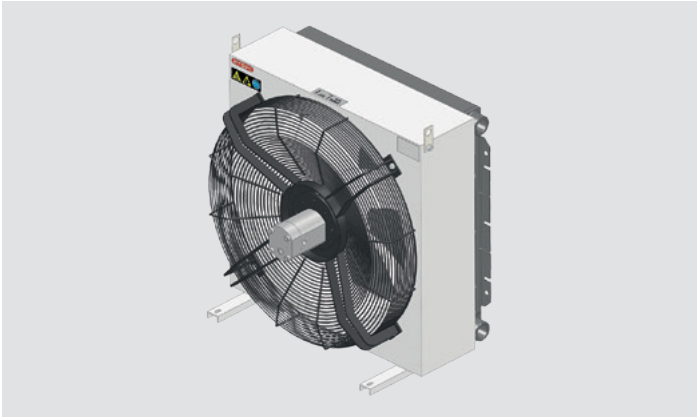

Air cooler with

- 1 Hydraulic motor
- 2 Finger guard
- 3 Axial fan
- 4 Fan housing
- 5 Heat exchanger

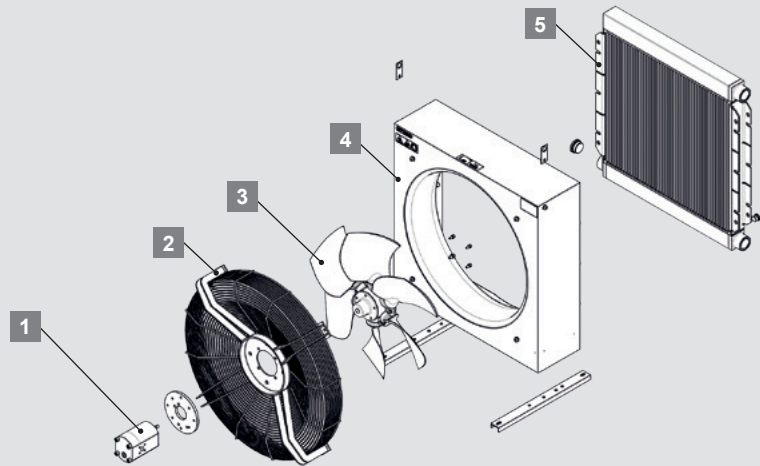

AC-LNH 10-11

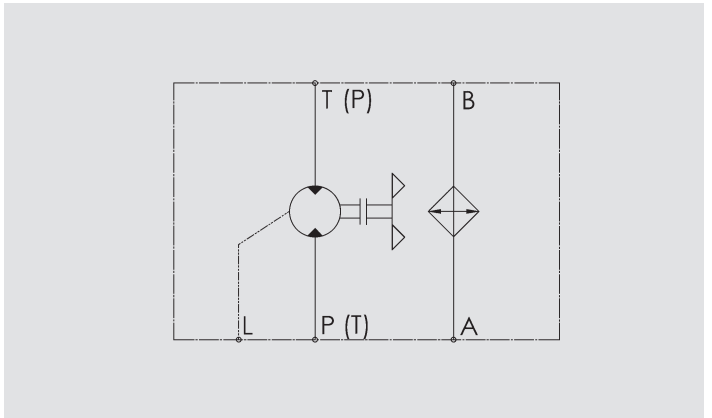

Air cooler with

- 1 Hydraulic motor
- 2 Finger guard
- 3 Axial fan
- 4 Fan housing
- 5 Heat exchanger

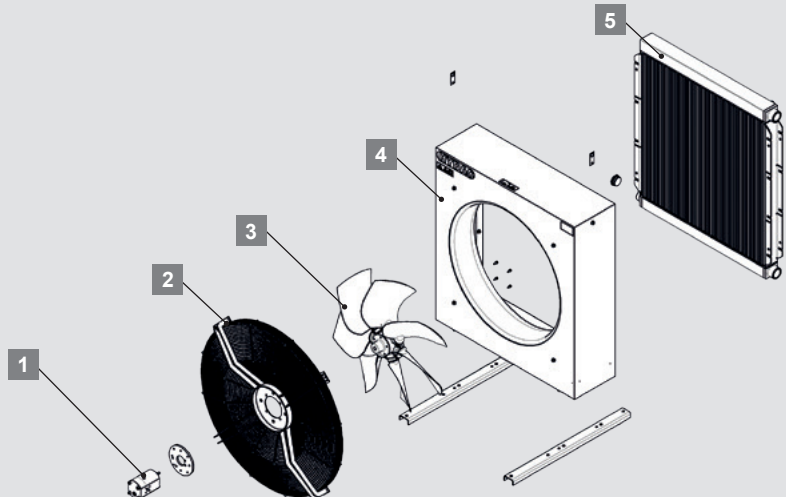

Design

AC-LNH 12-14

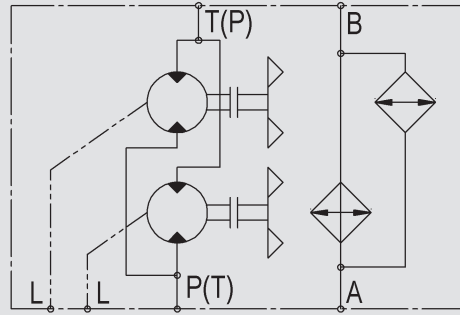
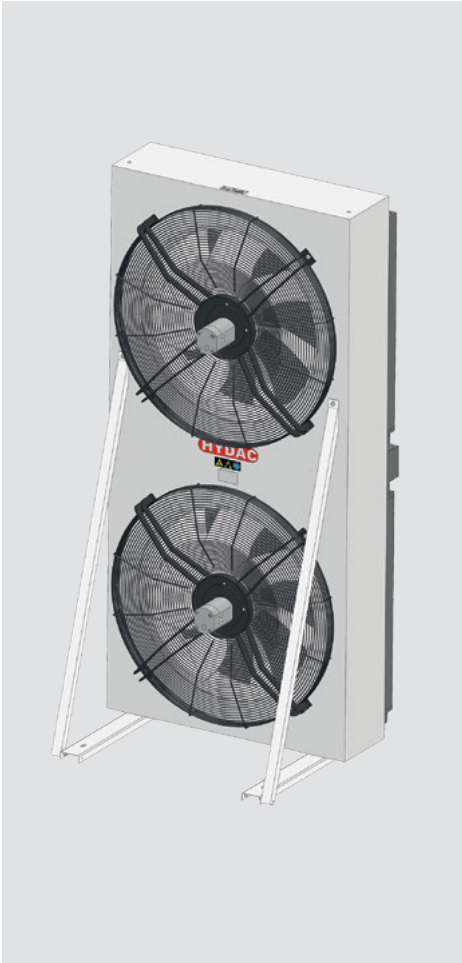

Air cooler with

- 1 Hydraulic motor
- 2 Finger guard
- 3 Axial fan
- 4 Fan housing
- 5 Heat exchanger

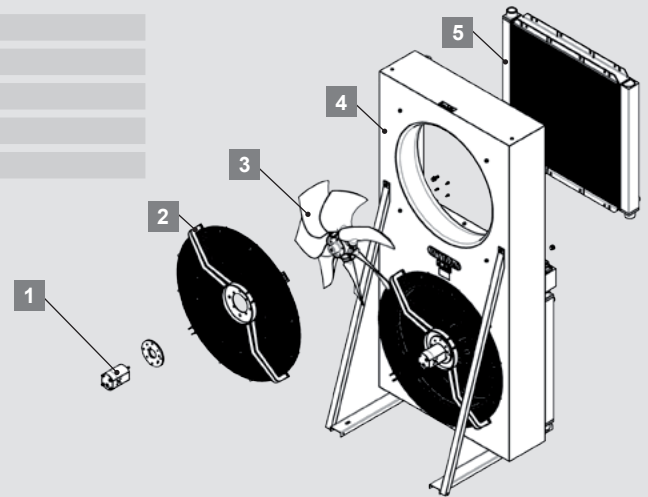

Technical Data

Type of cooler	P/N	Motor displacement [cm ³ /rev]	Operating speed range [rpm]	Fluid flow rate [l/min] ¹⁾	Air flow rate [m ³ /h] ¹⁾	Continuous motor operating pressure [bar]	Required pressure for max. speed [bar] ²⁾	Required motor oil flow at 1,500 rpm [l/min]	Noise level (at 1 m distance) [dB(A)]	Volume [l] ³⁾	Weight [kg] ⁴⁾
AC-LNH8	3903313	6.3	1,000 – 2,800	350	7,900	250	270	10.5	69	6	64
	3904781	14.0	1,000 – 2,800	350	7,900	250	120	23.0	69	6	64
	3904783	22.0	1,000 – 2,800	350	7,900	150	80	36.6	69	6	64
AC-LNH9	3903356	14.0	1,000 – 2,200	350	11,500	250	120	23.0	71	11	90
	3904830	22.0	1,000 – 2,200	350	11,500	150	80	36.6	71	11	90
AC-LNH10	3903358	14.0	1,000 – 1,800	540	18,600	250	210	23.0	77	14	120
	3904831	22.0	1,000 – 1,800	540	18,600	150	140	36.6	77	14	120
AC-LNH11	3903359	14.0	1,000 – 1,500	540	24,500	250	270	23.0	81	18	143
	3904832	22.0	1,000 – 1,500	540	24,500	150	180	36.6	81	18	143
AC-LNH12	3975153	14.0	1,000 – 1,800	840	18,600	250	210	23.0	77	28	270
	3975154	22.0	1,000 – 1,800	840	18,600	150	140	36.6	77	28	270
AC-LNH14	3975235	14.0	1,000 – 1,500	840	24,500	250	270	23.0	81	35	265
	3975236	22.0	1,000 – 1,500	840	24,500	150	180	36.6	81	35	265

¹⁾ Max. flow rate at fan speed of 1,500 rpm

²⁾ At viscosity 34 mm²/s

³⁾ Fluid in cooling element, AC-LNH 12-14: depending on cooling element

⁴⁾ Unfilled

Cooling Capacity and Pressure Difference Δp

Mineral oil

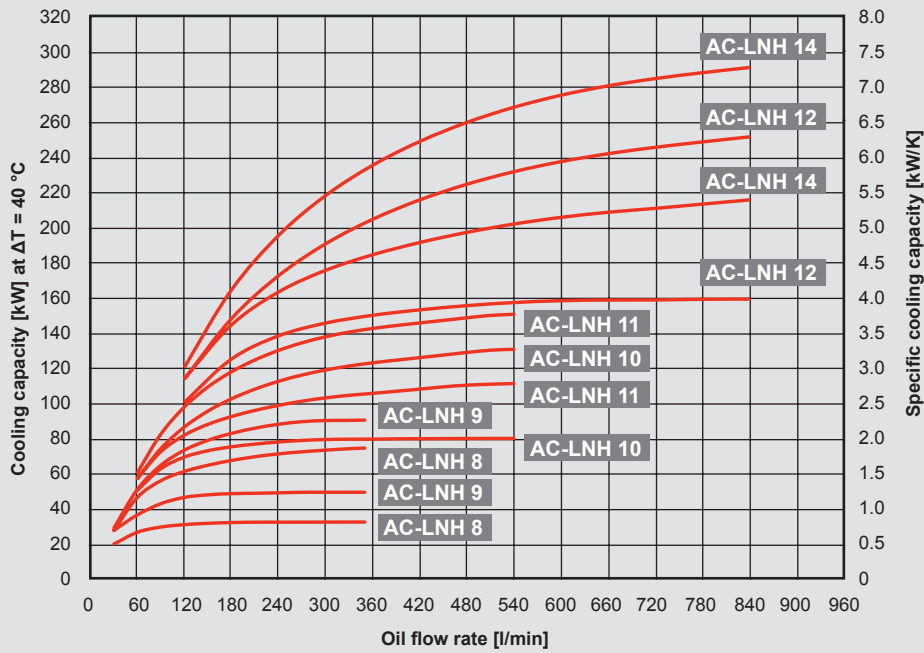

Tolerance: $\pm 5\%$

Cooling capacity:

Dependent on the oil flow rate and the temperature difference ΔT between oil inlet and air inlet.

Note:

The values are measured at $\Delta T = +40\text{ °C}$. For smaller ΔT values, the values can change.

You can also use our cooler calculation software for designing. Please contact our technical sales department.

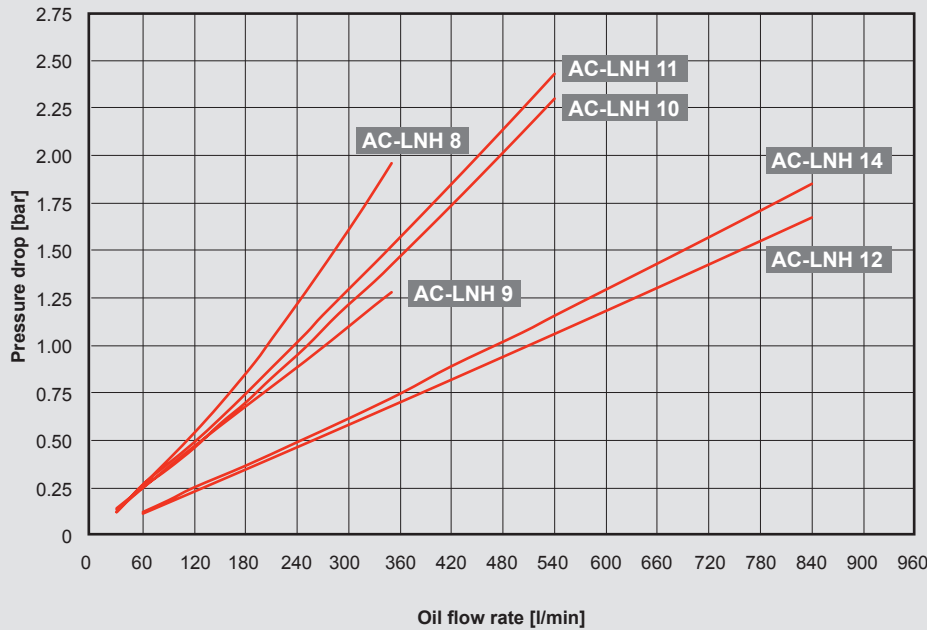

Measured at $30\text{ mm}^2/\text{s}$

Tolerance: $\pm 5\%$

Pressure difference Δp

For other viscosities, the pressure drop must be multiplied by the conversion factor K:

Viscosity (mm^2/s)	10	15	22	30	46	68	100	150
Factor K	0.35	0.5	0.75	1.0	1.4	1.9	2.5	3.5

Cooling Capacity and Pressure Difference Δp

Water glycol (60/40)

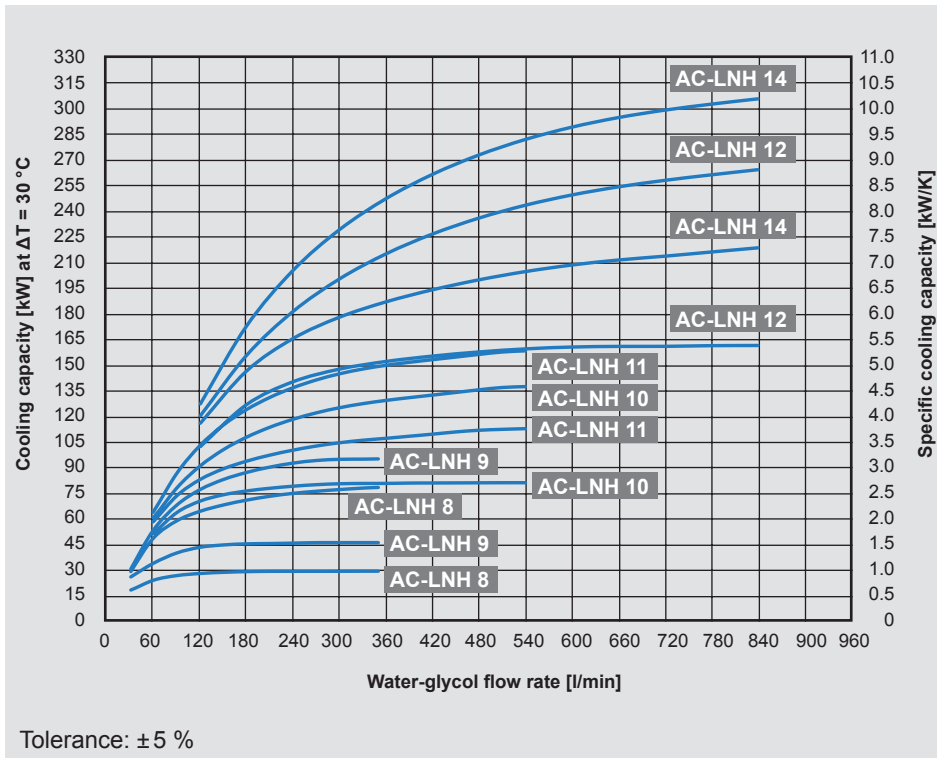

Cooling capacity:

Dependent on the water-glycol flow rate and the temperature difference ΔT between w/g inlet and air inlet.

Note:

The values are measured at $\Delta T = +30^\circ\text{C}$. For smaller ΔT values, the values can change. Please contact the technical sales department for designs with a temperature difference ΔT under $+10^\circ\text{C}$.

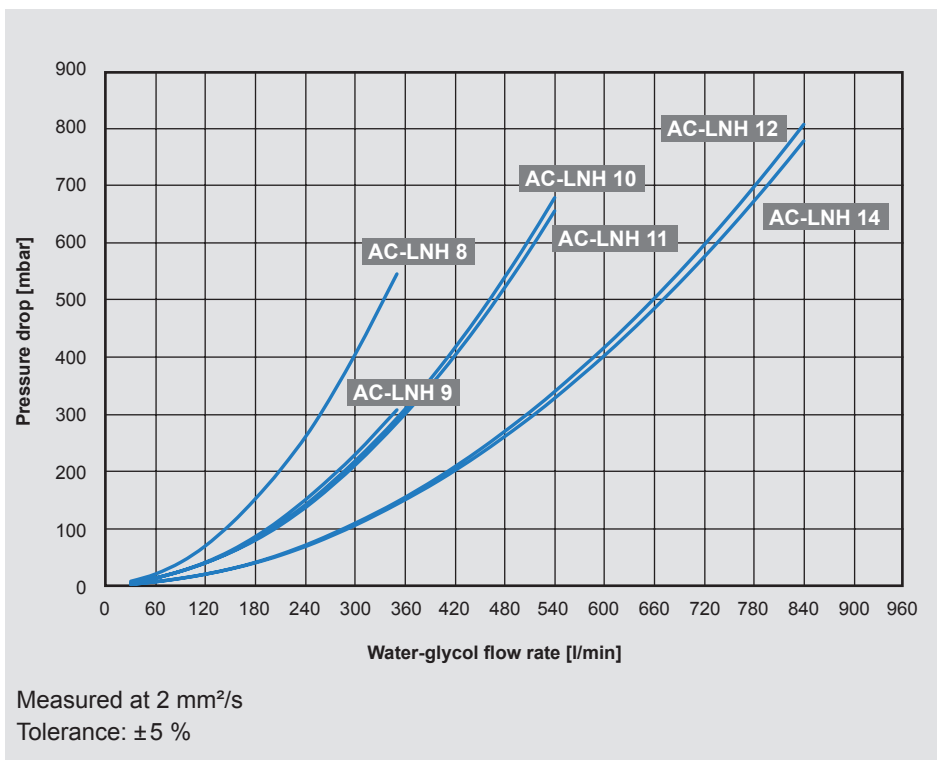

Pressure difference Δp

Model Code

AC-LNH 8 - 1.0 - H6.3TB - 1 - S - AITF60

Cooler type

AC-LNH = Air cooler (oil/water-glycol mix)

Size

8 – 14 = Size

Revision

Motor voltage

H6.3 = 6.3 cm³/r

H14 = 14 cm³/r

H22 = 22 cm³/r

H..TB = Hydraulic motor with thermal bypass

Colour

1 = RAL 9002 (standard)

Other colours on request.

Air flow direction

S = Suction (standard)

D = Blowing (on request)

Accessories

IBP = Heat exchanger with integrated pressure bypass valve (cannot be retrofitted)

IBT = Heat exchanger with integrated thermal pressure bypass valve (cannot be retrofitted)

AITF = Thermostat (fixed)

For other accessories, e.g. rubber buffer as vibration absorber, air filter grid or air filter mat, please see Air Cooler Accessories brochure.

Dimensions

AC-LNH 8-9

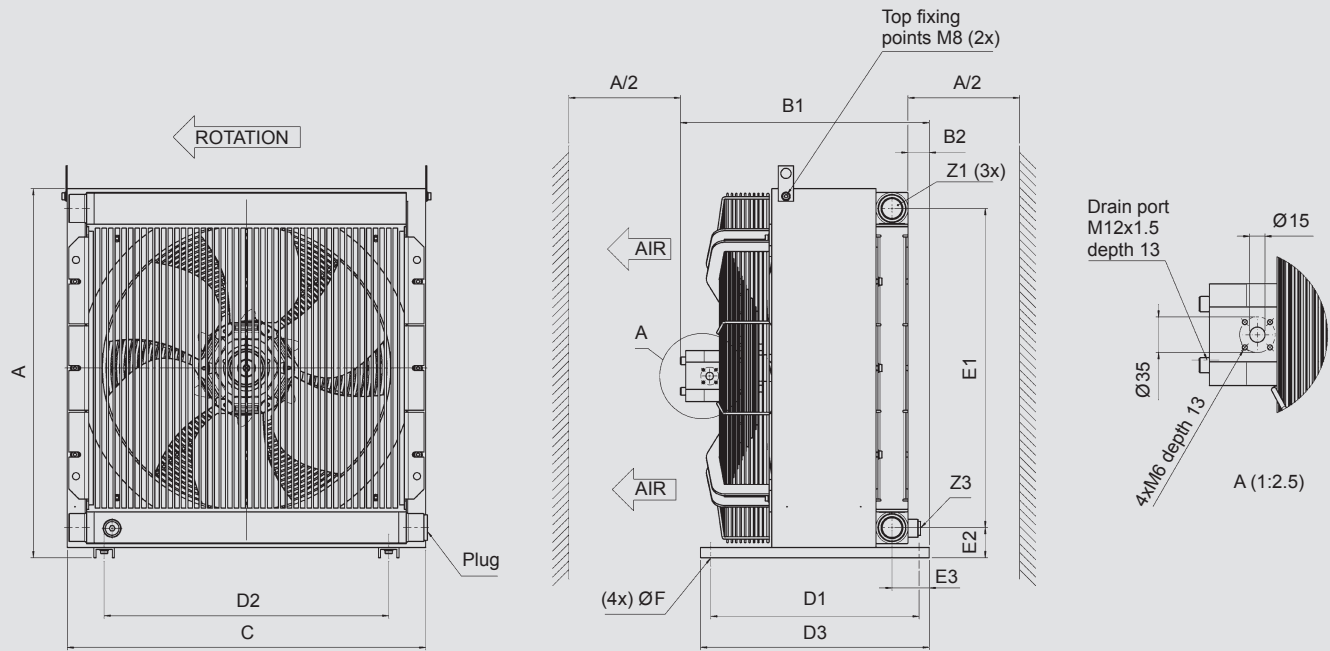

[mm]	A ±5	B1 ±10 6.3 cc	B1 ±10 14 cc	B1 ±10 22 cc	B2 ±5	C ±5	D1 ±5	D2 ±5	D3 ±5	E1 ±5	E2 ±5	E3 ±5	F Ø/hole	Z1	Z3
AC-LNH8	725	471	485	495	42	705	410	560	450	627	59	74	9x20	G1 1/4"	M22x1.5
AC-LNH9	880	-	639	649	107	790	750	700	790	757	77	148	Ø12	G1 1/2"	M22x1.5

Dimensions

AC-LNH 10-11

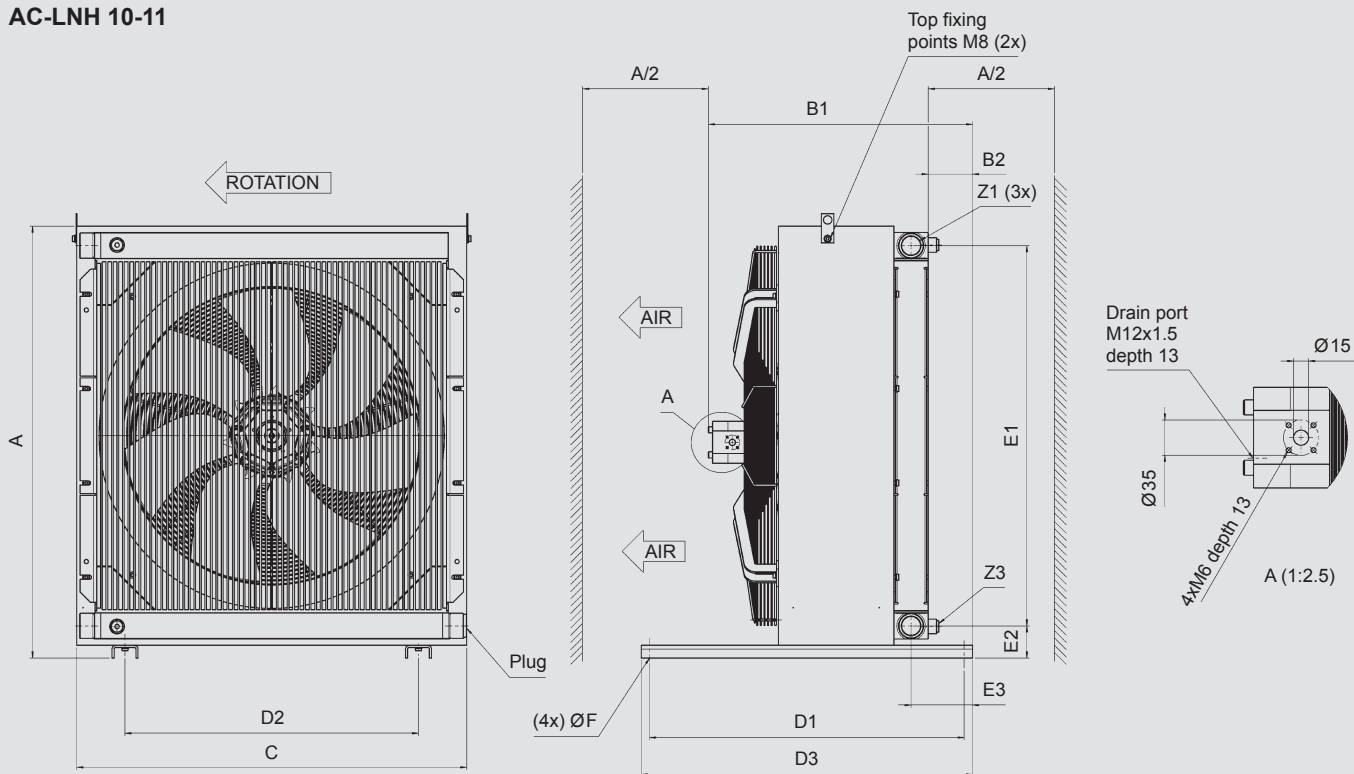

[mm]	A ±5	B1 ±10 14 cc	B1 ±10 22 cc	B2 ±5	C ±5	D1 ±5	D2 ±5	D3 ±5	E1 ±5	E2 ±5	E3 ±5	F Ø/hole	Z1	Z3
AC-LNH10	1,030	626	636	106	930	750	700	790	907	77	147	Ø12	G1 1/2"	M22x1.5
AC-LNH11	1,180	626	636	106	1,050	750	700	790	1,057	77	147	Ø12	G1 1/2"	M22x1.5

Dimensions

AC-LNH 12-14

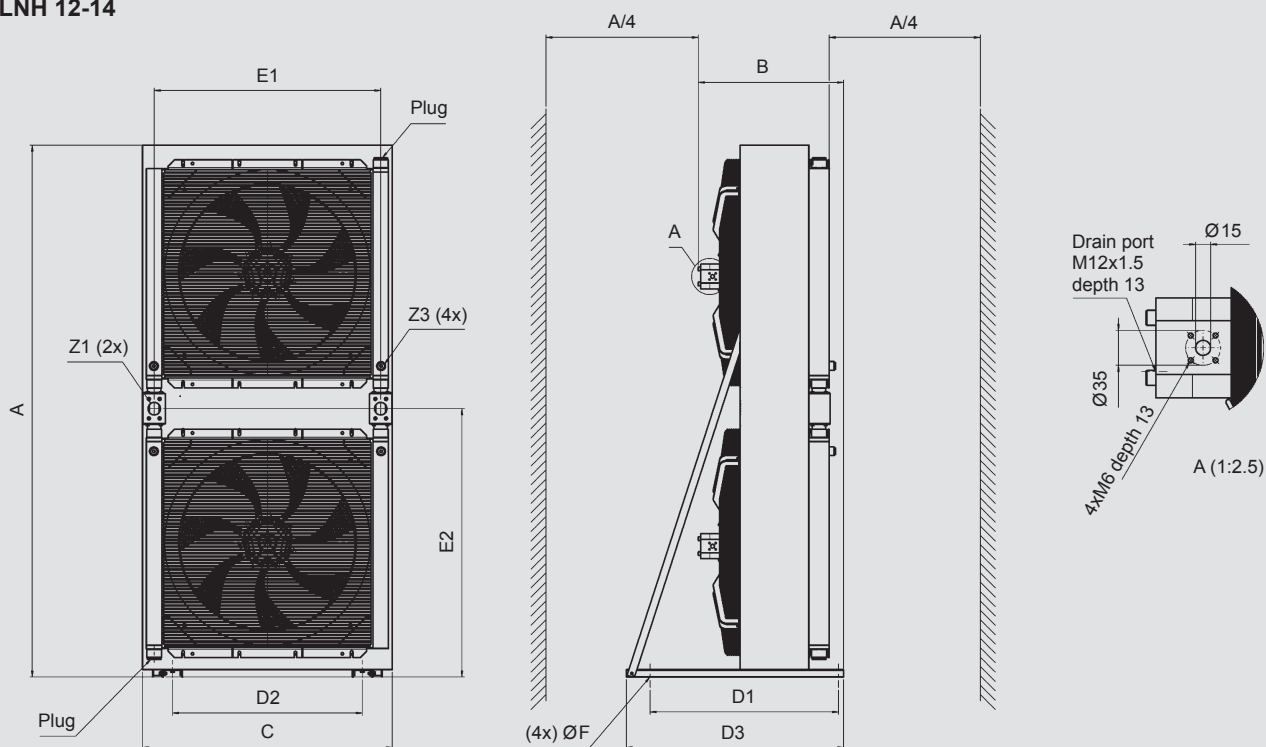

[mm]	A ±5	B ±10 14 cc	B ±10 22 cc	C ±5	D1 ±2	D2 ±2	D3 ±2	E1 ±5	E2 ±5	F Ø/hole	Z1	Z3
AC-LNH12	2,130	577	587	1,000	750	760	870	907	1,075	13x30	SAE G2"	M22x1.5
AC-LNH14	2,297	577	587	1,140	750	900	870	1,057	1,166	13x30	SAE G2"	M22x1.5

Note:

We recommend maintaining a minimum distance to ensure an unimpeded air inlet and air outlet. For sizes 8-11 this is half the height of the cooling element (A/2); for sizes 12-14 it is a quarter of the element height (A/4). Anything below the minimum distance can affect cooling capacity and noise emissions.

Note

The information in this brochure relates to the operating conditions and applications described.

For applications and operating conditions not described, please contact the relevant technical department.

Subject to technical modifications.



HYDAC COOLING GMBH

INTERNATIONAL

Industriegebiet
66280 Sulzbach/Saar
Germany

Tel.: +49 6897 509-01
Fax: +49 6897 509-454

E-mail: cooling@hydac.com
Internet: www.hydac.com

**HYDAC AG
Mezzovico Branch**

Via Sceresca, Zona Industriale 3
6805 Mezzovico
Switzerland

Tel.: +41 91 9355-700
Fax: +41 91 9355-701

E-mail: info@hydac.ch
Internet: www.hydac.com



Air Cooler Mobile OK-ELD 0-6 with DC motor

Symbol

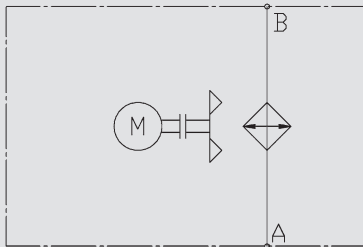

General

The OK-ELD air cooler series is designed specifically for mobile hydraulic applications where high performance and efficiency are required and physical size must be minimized to allow easy installation.

Product Features

These coolers use a combination of high performance cooling elements and high capacity, long life DC electric powered fans to give long trouble free operation in arduous mobile hydraulic applications. The compact design allows the coolers to fit most equipment and provide the highest cooling performance in heat dissipation whilst minimizing space required.

- Compact, efficient, high performance
- Cooling range 2-34 kW
- DC motors in 12 Volt and 24 Volt with motor lifetimes up to 16,000 hours

Application Field

Hydraulic systems in mobile machines and vehicles, such as

- Mobile cranes
- Concrete mixers and pump trucks
- Road paving machines
- Construction machines (excavators, wheel loaders)
- Agricultural machines
- Municipal machines

Operation Data

Fluids	<ul style="list-style-type: none"> ● Oils (mineral oils, synthetic oils, high viscosity oils, biological oils, phosphate ester) ● Water-glycol (cooling fluids) ● HFC pressure fluids
Viscosity	2,000 mm ² /s (standard)
Temperature range	<ul style="list-style-type: none"> ● Minimum / maximum ambient temperature: -20 °C to +40 °C (standard) ● Minimum / maximum temperature of the medium: +20 °C to +130 °C <p>Please contact the technical sales department in the event of deviating temperatures.</p> <p>Notice! Fan at max. speed (max. volume of air) must be avoided when operating a cooler at which the temperature difference between the medium inlet at the cooler and the ambient temperature can be greater than 50 °C. Quick changes in the temperature of the cooling element material can lead to a significant reduction in service life or to direct damage of the cooling element due to thermal shock. Please contact the technical sales department to receive information about controlled fan drives.</p>
Pressure resistance of the cooling element	<ul style="list-style-type: none"> ● Dynamic operating pressure: 16 bar ● Static operating pressure: 21 bar
Fan	<p>Axial fan in suction version (standard) Axial fan in pushing version on request (note: approx. 10 % less cooling capacity)</p>
Motor	<ul style="list-style-type: none"> ● DC motor ● 12 V / 24 V ● Protection class IP68 ● Insulation class F <p>Other versions on request.</p>
Noise levels	<p>See technical data The noise levels are only reference values as the acoustic properties of a room, connections and reflection have an effect on the noise level.</p>
Accessories	<ul style="list-style-type: none"> ● Integrated pressure bypass valve (IBP) or integrated thermal pressure bypass valve (IBT) (cannot be retrofitted, also see options) ● Brushless fan ● Electronic speed control (ESC) ● Thermostats ● Air filter grid or air filter mat ● Vibration damper

Options

Integrated pressure bypass valve (IBP) / Integrated thermal pressure bypass valve (IBT)

The bypass channel is integrated in the cooling element. If a particular pressure is exceeded, the IBP opens the bypass channel, thereby protecting the cooling element from too high a pressure. Furthermore, the IBT only opens the cooling element path once a particular temperature has been reached.

Design

OK-ELD 0

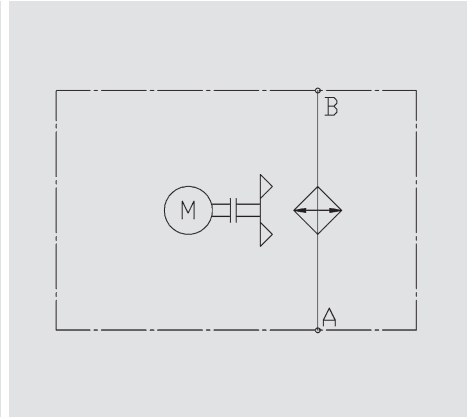
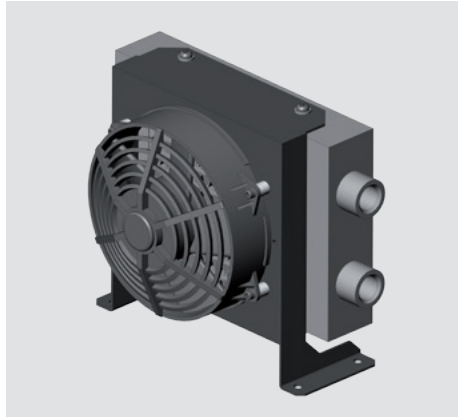

Air cooler with

- 1 Axial fan with integrated motor
- 2 Fan housing
- 3 Heat exchanger

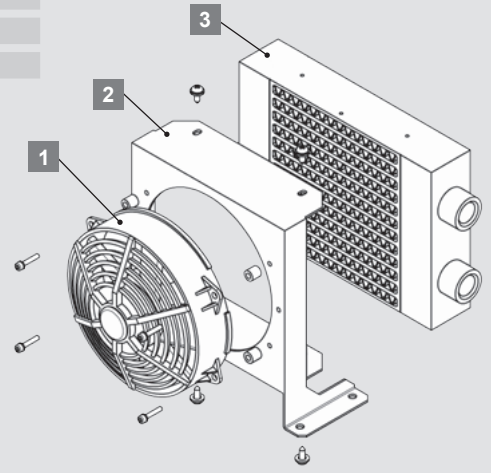

OK-ELD 1.5

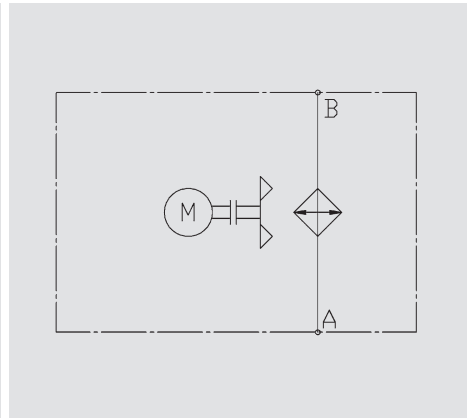
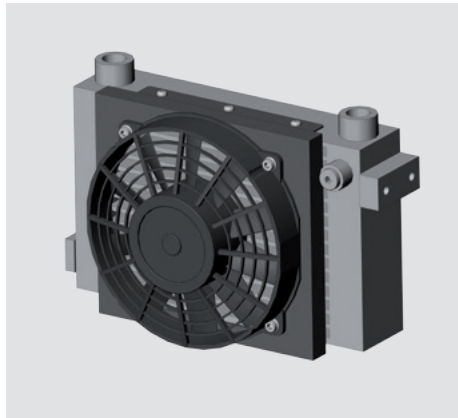

Air cooler with

- 1 Axial fan with integrated motor
- 2 Fan housing
- 3 Heat exchanger

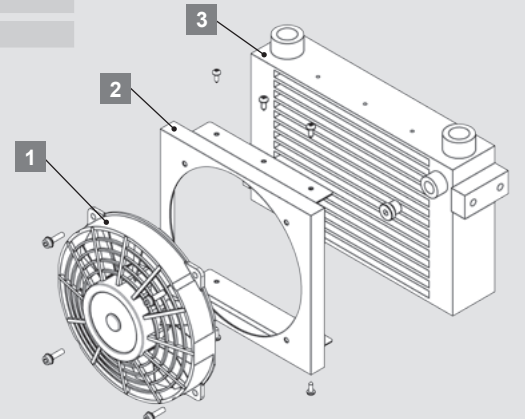

Design

OK-ELD 1-4.5

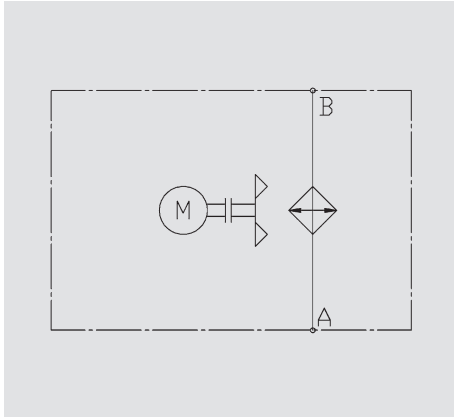
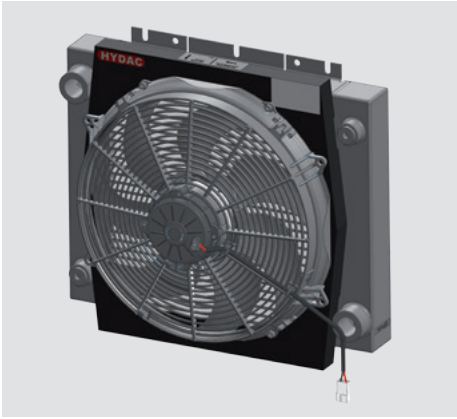

Air cooler with

- 1 Axial fan with integrated motor
- 2 Fan housing
- 3 Heat exchanger

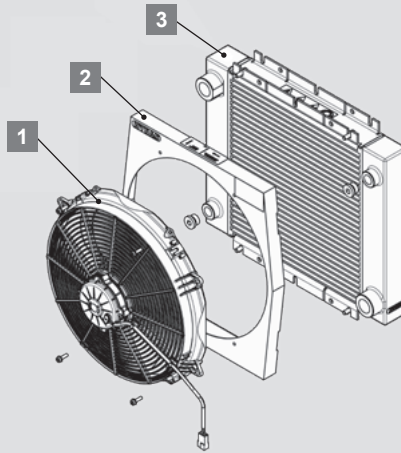

OK-ELD 5-6

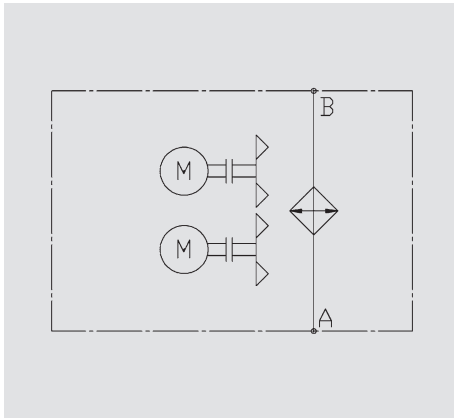

Air cooler with

- 1 Axial fan with integrated motor
- 2 Fan housing
- 3 Heat exchanger

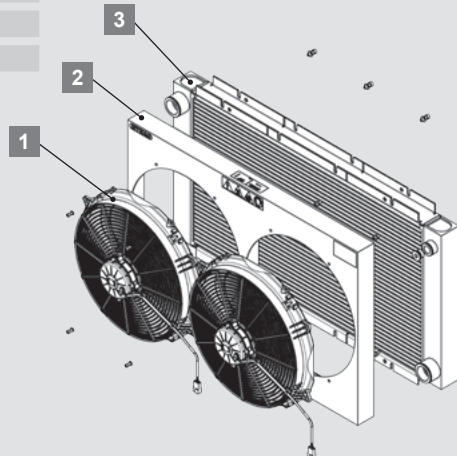

Technical Data

OK-ELD 0-6

Type of cooler	P/N	Voltage [V]	Fluid flow [l/min] ¹⁾	Air flow [m ³ /h]	Fan motor: Power / current absorption [kW / A] ²⁾		Recommended Fuse [A]	Fan Diameter [mm] ²⁾	Noise level (at 1 m distance) [dB(A)]	Volume [l] ³⁾	Weight [kg] ⁴⁾
					kW	A					
OK-ELD 0	3169981	12	60	279	0.05	3.0	5.0	140	68	0.4	2.7
OK-ELD 0	3169980	24	60	279	0.05	1.6	5.0	140	68	0.4	2.7
OK-ELD 1	3083371	12	150	451	0.10	8.0	15.0	190	73	0.6	4.0
OK-ELD 1	3083596	24	150	451	0.10	3.2	7.5	190	73	0.6	4.0
OK-ELD 1.5	3106405	12	150	455	0.10	8.0	15.0	190	77	1.0	4.7
OK-ELD 1.5	3106406	24	150	455	0.10	4.0	7.5	190	77	1.0	4.7
OK-ELD 2	3083370	12	150	910	0.14	9.4	20.0	255	74	2.0	9.4
OK-ELD 2	3083597	24	150	910	0.14	5.2	15.0	255	74	2.0	9.4
OK-ELD 3	3083369	12	180	1,338	0.23	17.5	25.0	305	79	2.2	11.0
OK-ELD 3	3083678	24	180	1,338	0.23	8.0	20.0	305	79	2.2	11.0
OK-ELD 4	3809511	12	180	2,052	0.30	22.5	30.0	385	76	3.0	15.9
OK-ELD 4	3809078	24	180	2,052	0.30	10.5	20.0	385	76	3.0	15.9
OK-ELD 4.5	3979800	12	180	2,284	0.30	22.5	30.0	385	76	5.2	22.0
OK-ELD 4.5	3979801	24	180	2,284	0.30	10.5	20.0	385	76	5.2	22.0
OK-ELD 5	3083286	12	180	3,581	0.46	35.0	2x25	305	80	4.2	30.3
OK-ELD 5	3083681	24	180	3,581	0.46	16.0	2x20	305	80	4.2	30.3
OK-ELD 6	3982479	12	180	5,020	0.60	45.0	2x30	385	77	5.2	36.6
OK-ELD 6	3982420	24	180	5,020	0.60	21.0	2x20	385	77	5.2	36.6

¹⁾ Max. flow rate

²⁾ OK-ELD 5-6: each fan

³⁾ Fluid in cooling element

⁴⁾ Unfilled

Counter connector

Type of cooler	P/N	
OK-ELD 0	12 V	3973604
	24 V	3973656
OK-ELD 1	12 V / 24 V	3973602
OK-ELD 1.5	12 V / 24 V	3973602
OK-ELD 2	12 V / 24 V	3973602
OK-ELD 3	12 V / 24 V	3176990
OK-ELD 4	12 V / 24 V	3973602
OK-ELD 4.5	12 V / 24 V	3973602
OK-ELD 5	12 V / 24 V	(2x) 3176990
OK-ELD 6	12 V / 24 V	(2x) 3973602

Cooling Capacity and Pressure Difference Δp

OK-ELD 0-6

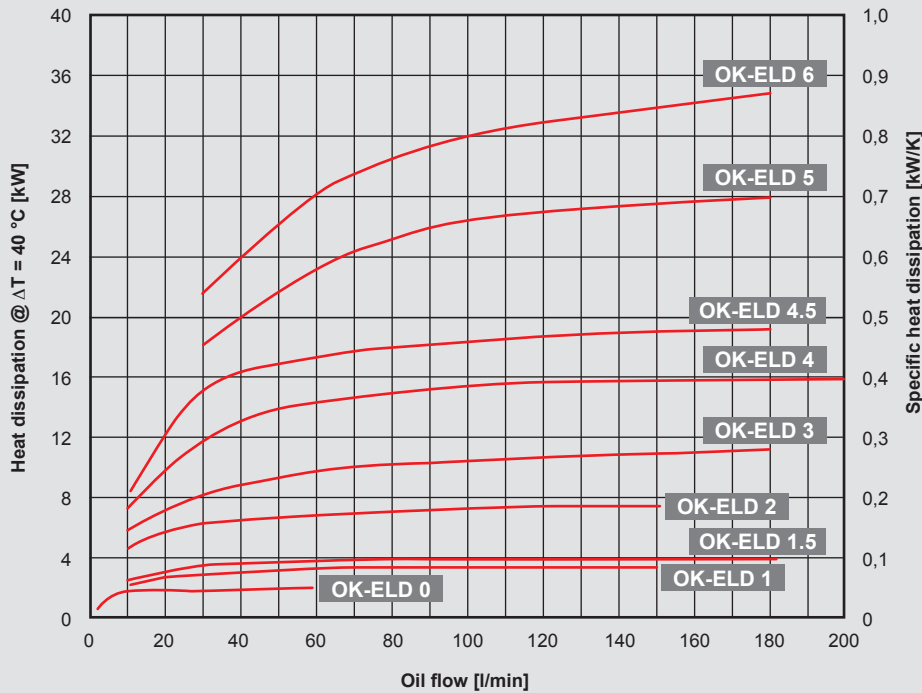

Tolerance: $\pm 5\%$

Cooling capacity:

Dependent on the oil flow rate and the temperature difference ΔT between oil inlet and air inlet.

Note:

The values are measured at $\Delta T = 40\text{ °C}$. For smaller ΔT values, the values can change. You can also use our cooler calculation software for designing. Please contact our technical sales department.

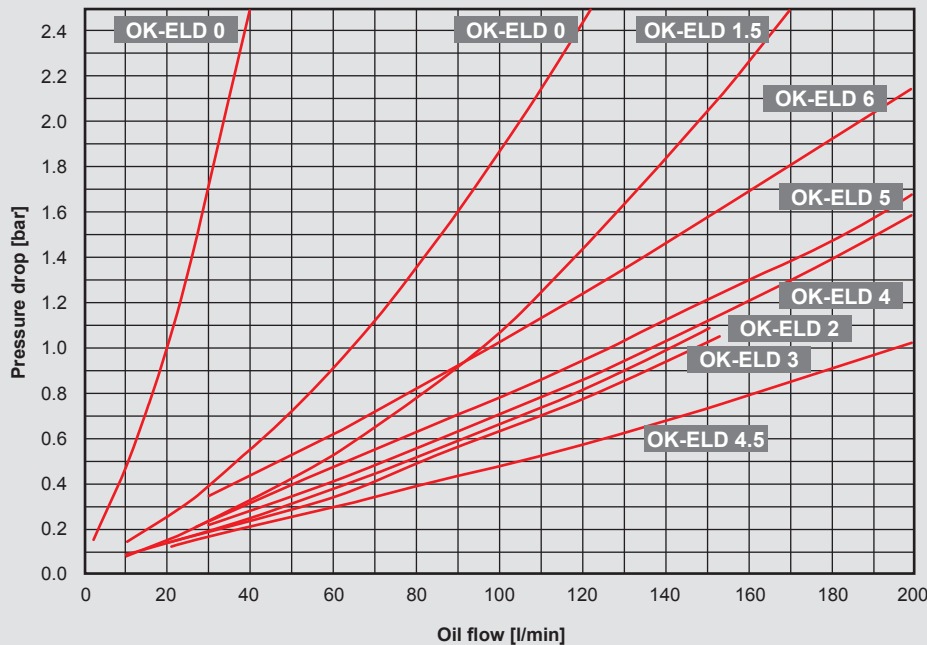

measured at $30\text{ mm}^2/\text{s}$
Tolerance: $\pm 5\%$

Pressure difference Δp

For other viscosities, the pressure loss must be multiplied by the conversion factor K:

Viscosity (mm^2/s)	10	15	22	30	46	68	100	150
Factor K	0.35	0.5	0.75	1.0	1.4	1.9	2.5	3.5

Model Type

OK-ELD - 1H - 3.1 - 12 VBL - 1 - S - AITF60

Cooler type

OK-ELD = Oil-Air cooler

Size / motor speed

0-6 = size

H = 2 pl (3,000 min⁻¹)

Revision

Motor voltage

12 V = 12 V DC

24 V = 24 V DC

12 VBL = 12 V DC brushless

24 VBL = 24 V DC brushless

Color

1 = RAL 9005 (standard)

Other colors on request.

Air flow direction

S = Suction (standard)

D = Blowing

Accessories

IBP = Heat exchanger with integrated bypass valve

IBT = Heat exchanger with integrated thermo-bypass valve

AITF = Thermostat (fixed)

ESC = Electronic speed control

For all possible accessories, like vibration absorber, air filter grid or air filter mat, please refer to brochure Accessories for air coolers.

Dimensions

OK-ELD 0

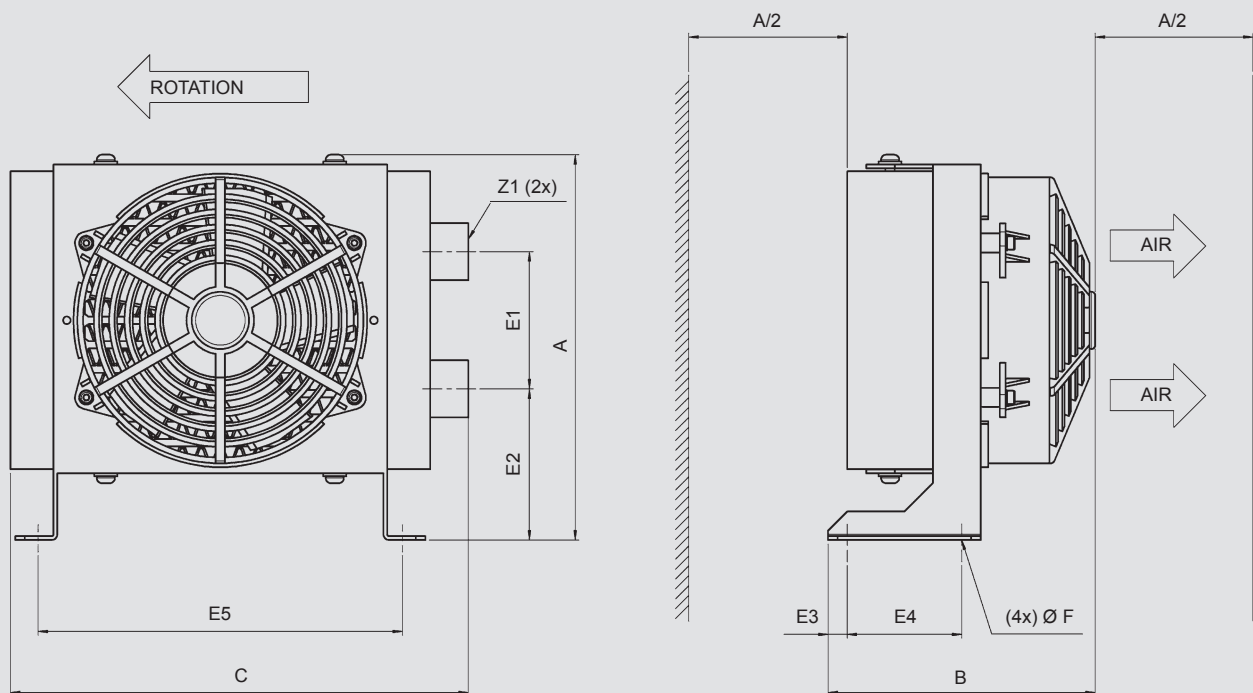

Dimensions

OK-ELD 1.5

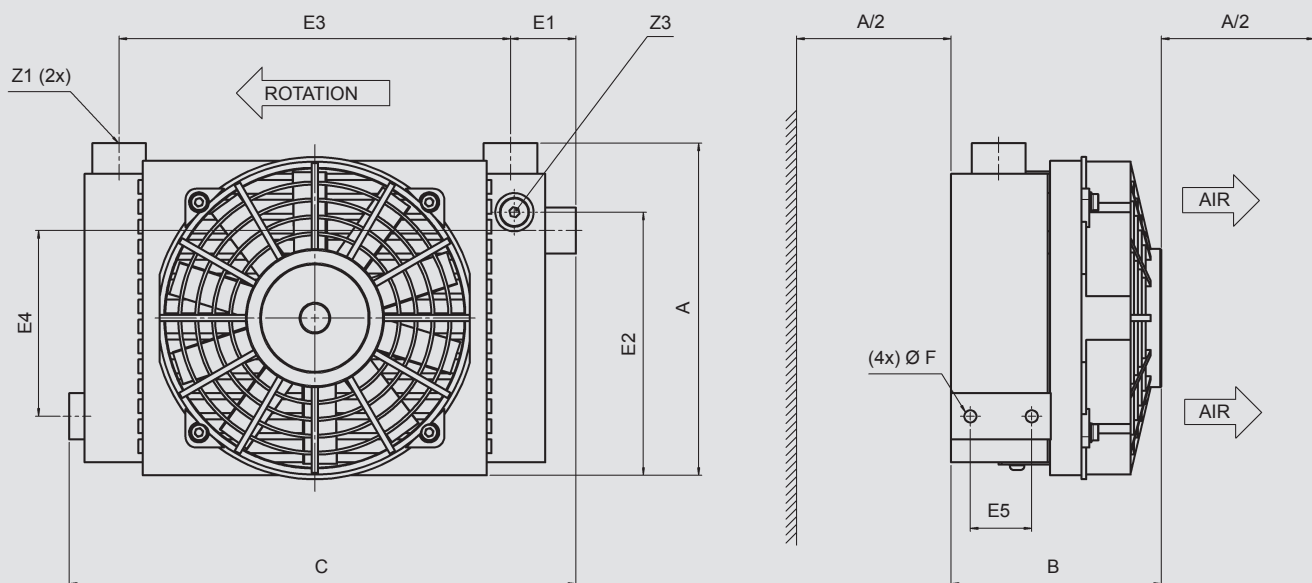

Dimensions

OK-ELD 1-4

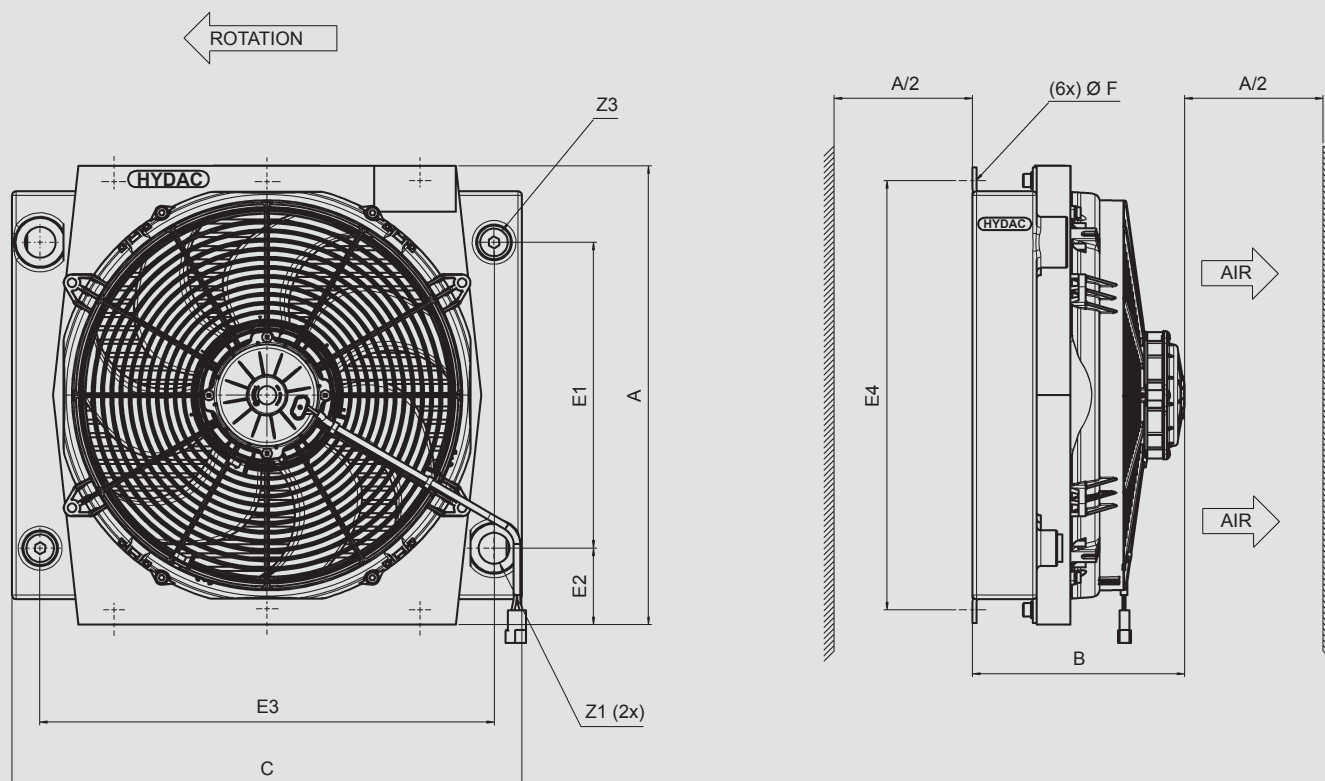

[mm]	A ±5	B ±10	C ±5	E1 ±5	E2 ±5	E3 ±5	E4 ±5	E5 ±2	F ø/slot	Z1	Z3
OK-ELD 0	202	140	240	72	79	10	60	190	6.5	G½"	–
OK-ELD 1	245	120	300	125	60	250	225	180 ¹⁾	9.0	M22x1.5	M22x1.5
OK-ELD 1.5	217	137	330	43	172	255	121	40	M8	M22x1.5	M14x1.5
OK-ELD 2	313	207	384	199	57	324	288	80	14x10	G1"	M22x1.5
OK-ELD 3	356	207	420	230	63	370	329	100	14x10	G1"	M22x1.5
OK-ELD 4	450	208	500	300	75	445	421	150	19x10	G1"	M22x1.5 ²⁾
OK-ELD 4.5	454	227	602	350	52	495	200	580 ¹⁾	12.0	G1-¼"	M22x1.5 ²⁾

¹⁾ OK-ELD 1 and OK-ELD 4.5 have only the four external fixing points

²⁾ OK-ELD 4 and OK-ELD 4.5 have two connections M22x1.5

Dimensions

OK-ELD 5-6

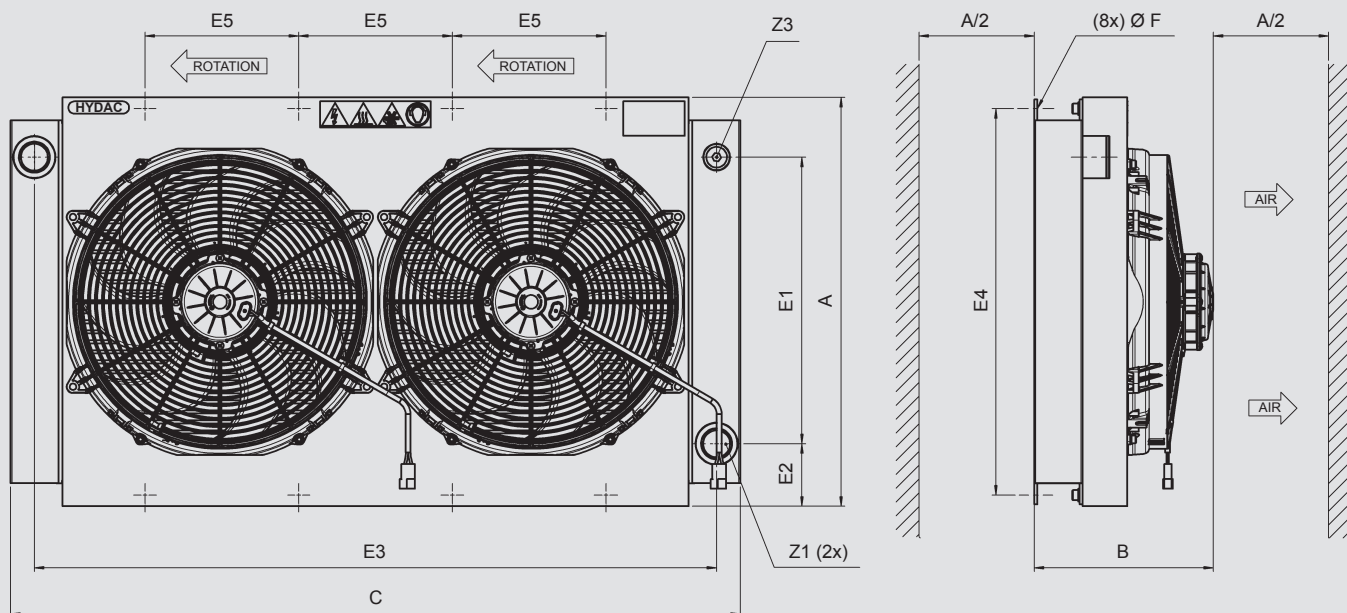

[mm]	A ±5	B ±10	C ±5	E1 ±5	E2 ±5	E3 ±5	E4 ±5	E5 ±2	F ø/slot	Z1	Z3
OK-ELD 5	480	232	810	321	79	750	450	170	10x20	G1-1/4"	M22x1.5
OK-ELD 6	532	233	950	373	81	888	503	200	9x21	G1-1/4"	M22x1.5

Note:

We recommend maintaining a minimum distance to ensure an unimpeded air inlet and air outlet. This is half the height of the cooling element (A/2). Anything below the minimum distance can influence the cooling capacity and the noise emissions.

Note

The information in this brochure relates to the operating conditions.

For applications and operating conditions not described, please contact the relevant technical department.

Subject to technical modifications.



HYDAC COOLING GMBH

Industriegebiet
66280 Sulzbach/Saar
Germany

Tel.: +49 6897 509-01
Fax: +49 6897 509-454

E-mail: cooling@hydac.com
Internet: www.hydac.com

**HYDAC AG
Mezzovico Branch**

Via Sceresca, Zona Industriale 3
6805 Mezzovico
Switzerland

Tel.: +41 91 9355-700
Fax: +41 91 9355-701

E-mail: info@hydac.ch
Internet: www.hydac.com

Mobile Coolers CMS – Cooling Mobile System



Hydraulic oil cooling on loader crane:
air cooler with DC motor



Hydraulic oil cooling on concrete pump:
air cooler with hydraulic motor and integrated filter



Combination cooler for forestry machine:
air cooler for 4 cooling circuits with fine filter grille, in folding design for easy, tool-free cleaning

General

The Emissions Directive for engines in mobile machinery has been structured to reduce emissions progressively which can lead to a drastic increase in the required heat dissipation and a corresponding adjustment in cooler size. The limited installation space available in a mobile machine must therefore be utilised efficiently and intelligently.

In mobile machines, multiple cooling circuits can be combined together in various ways in a CMS mobile cooler:

- Charge air cooling
- Coolant cooling
- Oil-cooling:
gearbox, hydraulics,
fan drive, axles
- Fuel cooling
- Condenser
If required, a heat exchanger for the A/C condenser can also be integrated into the cooling system

Product Features

The cooler comprises a set of cooling elements in different layouts, either side-by-side or front-to-back. With the addition of a fan cover, a protective grille and a fan (also available with motor) this cooler package is supplied to the customer ready for installation.

KULI simulation software is used to determine the optimal combination and configuration of heat exchangers and fan. In addition, CFD software can be used to visualise and calculate air flow and heat management in the engine compartment. This helps to reduce development costs.

Special cooling fins ensure suitability for use in dusty environments, for example, in agriculture and forestry or for applications in the mining sector.

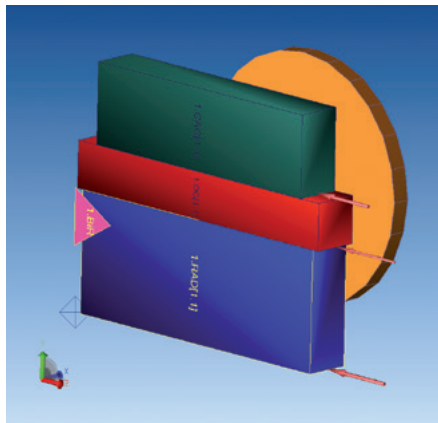

Side-by-side layout

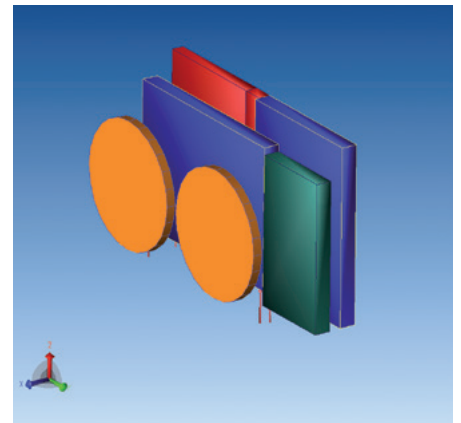

Front-to-back layout

Options

Fan controls

The efficiency of a cooler also depends largely on the fan control.

For DC and hydraulic motors, various options are used, such as the electronic speed control ESC, the temperature bypass TB or a proportional valve that continuously adjusts the fan speed according to the fluid temperature.

This means that the fan speed can be tailored directly to the required cooling capacity, i.e. just sufficient power is supplied to the fan as is immediately required.

As an option, these controls can also be supplied with a reversing function to "purge" the cooler of coarse contamination, such as lint, paper or fragments of vegetation.

Application Field

- Municipal vehicles and municipal machines
- Cement mixers and concrete pump trucks
- Agricultural and forestry machinery
e.g. tractors, harvesters, sprayers, combine harvesters
- Road construction machinery,
e.g. paver finishers, rollers, bulldozers, graders
- Dump truck

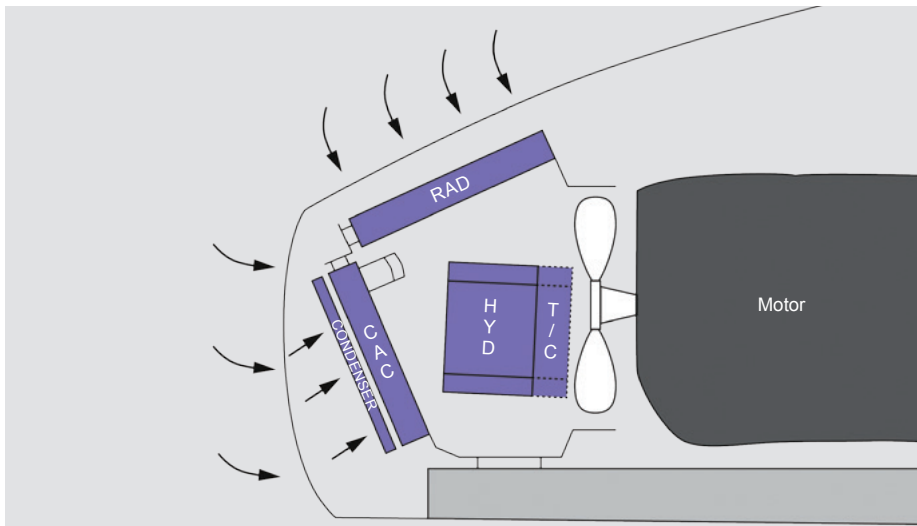

Configuration of the cooling elements in the engine compartment

Note

The information in this brochure relates to the operating conditions and applications described.

For applications and operating conditions not described, please contact the relevant technical department.

Subject to technical modifications and corrections.

Integration solutions

A variety of equipment can be integrated to produce customised solutions:

- Tank, filter and fan housing
- Integrated bypass valve – pressure (IBP) / Integrated bypass valve – temperature and pressure (IBT)
- Control

Combined in one component, they make a significant contribution to reducing installation space.

- Mobile cranes
- Wheel loaders
- Backhoe loaders
- Wheeled excavators and crawler excavators
- Snow grooming vehicles
- Vibrator survey trucks

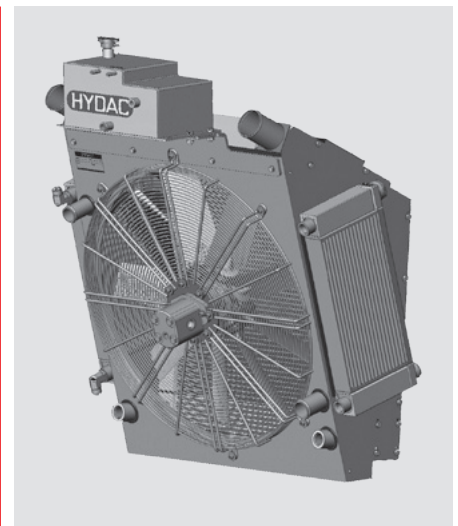

Combination cooler for sprayer: air cooler for 4 cooling circuits with hydraulic fan control

HYDAC

HYDAC COOLING GMBH

HYDAC AG
Mezzovico
branch office

INTERNATIONAL

Industriegebiet
66280 Sulzbach/Saar
Germany

Tel.: +49 6897 509-01
Fax: +49 6897 509-454

E-mail: cooling@hydac.com
Internet: www.hydac.com

Via Sceresca, Zona Industriale 3
6805 Mezzovico
Switzerland

Tel.: +41 91 9355-700
Fax: +41 91 9355-701

E-mail: info@hydac.ch
Internet: www.hydac.com

Air Cooler Accessories

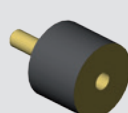
Cooler	Size	AITR	AITF	IBP	IBT	GP	Feet	ESC	LFG LFM LS
									
AC-LN	1	•	•			•			
	2-14	•	•	•	•	•			•
ACA-LN ACAF-LN	2-14			•	•	•			•
OK-ELC	0					•			
	1		•			•			•
	2-7	•	•	•	•	•			•
OSCA OSCAF	0					•			
	1-3					•			•
OK-ELD	0					•			
	1-1,5		•			• with feet	•	•	•
	2-6	•	•	•	•	• with feet	•	•*	•
OK-ELH	2-5	•	•	•	•	• with feet	•		•
	6-7	•	•	•	•	•			•
AC-LNH	8-14	•	•	•	•	•			•

* OK-ELD 5-6: special ESC for double fan is required.

Note:
Overall dimensions could be increased due to the presence of accessories.

Please contact the technical sales department for combination of accessories.

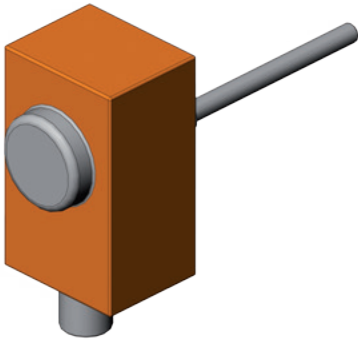

Thermostat adjustable TR/AITR

Symbol (AITR)

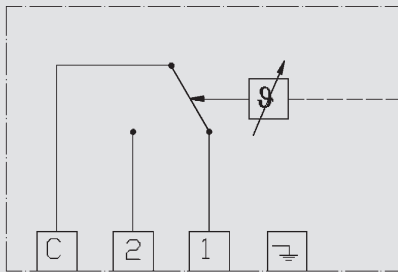

Operation Data

Temperature range	0 bis 90 °C +/- 3 °C
Switching differential	4 bis 8 °C
Storage temperature	-15 °C / +55 °C
Contacts ratings C1/C2	(C-1) 10(2.5)A NC/250 V (C-2) 6(2.5)A NO/250 V
Cable gland	M20 x 1.5
Max. ambient temperature	80 °C
Max. bulb temperature	125 °C
Rate of temperature change	1 K/min
Degree of protection	IP 40
Max. working pressure	10 bar

General

The TR/AITR is an electrical switch, opening or closing the circuit at the selected temperature.

TR could be mounted in the tank;
AITR is mounted in one of the cooling element free ports.

TR/AITR are supplied with a probe holder.

Dimensions

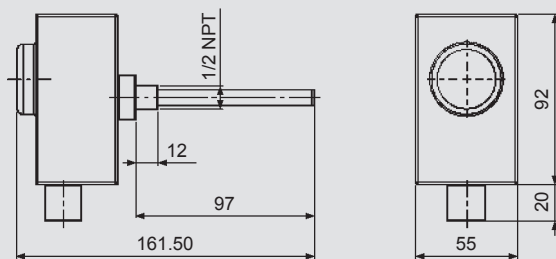

Installation

The position of the thermostat is in relation of the element design and position of ports.

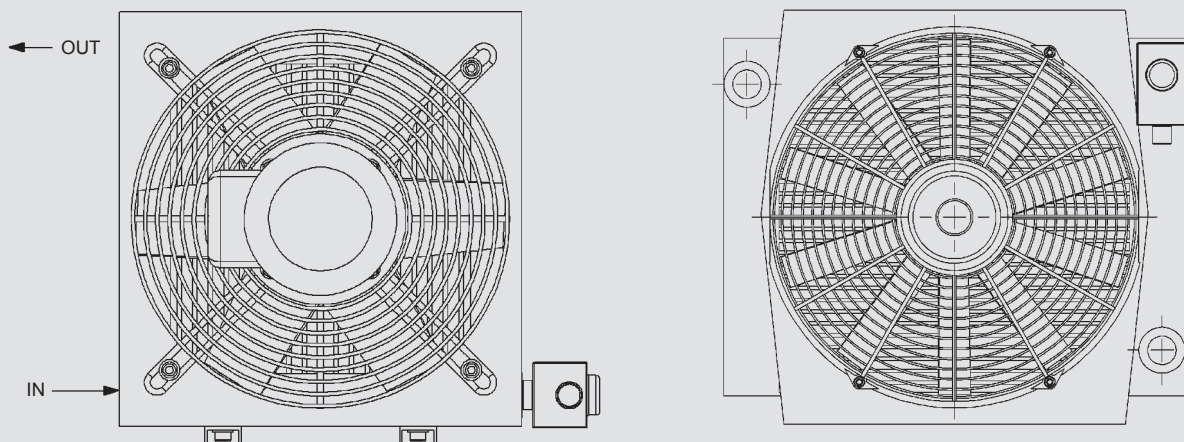

Model Type

Please check cooler compatibility in the table.

as accessory:

... / **AITR 30-90**

Working temperature range

AITR = Connection block with thermostat

as spare part:

AITR 30-90 / ...

Cooler / connection dimension

Working temperature range

AITR = Connection block with thermostat

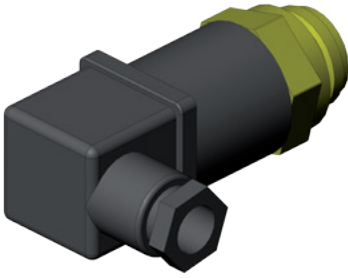

Thermostat fixed AITF

Symbol

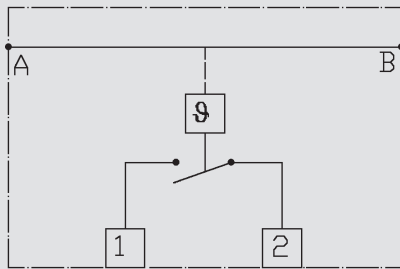

General

The AITF is an electrical switch, closing the circuit at a certain fixed temperature.

TF could be mounted in the tank; AITF is mounted in one of the cooling element free ports including the adaptors.

Operation Data

Case	Brass
Operating temperature	-20 °C/+120 °C
Contacts	NO (normally open)
Switching differential	10 °C at temperature change rate of 0.5 °C/min
Tolerance	+/- 3.5 °C at temperature change rate of 1 °C/min
Operating voltage/current	220 V AC / 10 A – 125 V AC / 15 A – 12-24 V DC / 2A
Electrical connections	according to DIN 43650
Hydraulic connection thread	M22X1.5 standard (1/2" BSP, 3/8" BSP on request)
Seal material	NBR
Life time	100,000 cycles
Protection degree	IP65 standard
Max. working pressure	200 bar

Dimensions

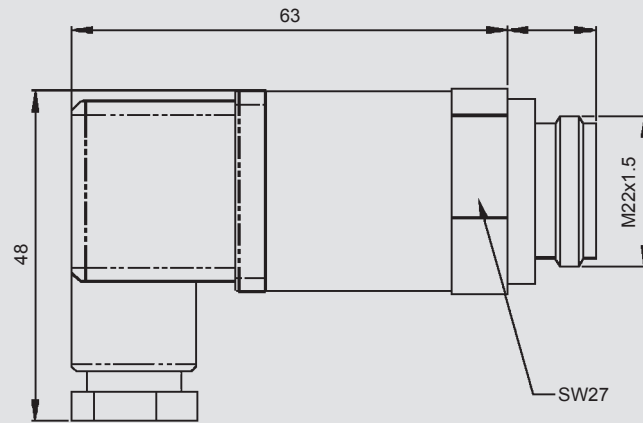

Model Type

Please check cooler compatibility in the table.

as accessory:

... / AITF 50

Switch-on temperature

AITF = Connection block with thermostat

as spare part:

AITF 50 / ...

Cooler / connection dimension

Switch-on temperature

AITF = Connection block with thermostat

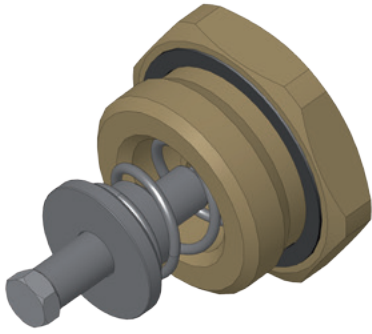

Integrated Pressure Bypass Valve IBP

Symbol

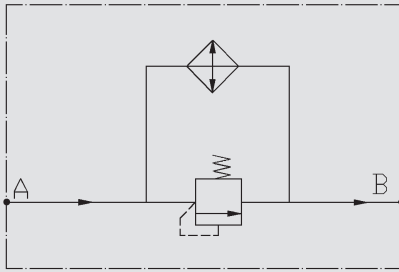

Operation Data

- Low pressure drop
- Works in any position
- Maintenance-free
- Max. working pressure: 16 bar

IBP version	Available opening pressure
IBP2	2 bar
IBP3	3 bar
IBP4	4 bar
IBP6	6 bar

General

The IBP is a valve that closes the bypass channel of the cooler. When the pressure exceeds a certain value in the cooling the IBP opens the bypass channel and allows a part of the fluid to bypass the element.

Note:

This valve requires a special cooling element with integrated bypass channel. Therefore, it cannot be retrofitted.

Installation

Inlet port is always placed on the tank where the IBP is assembled.

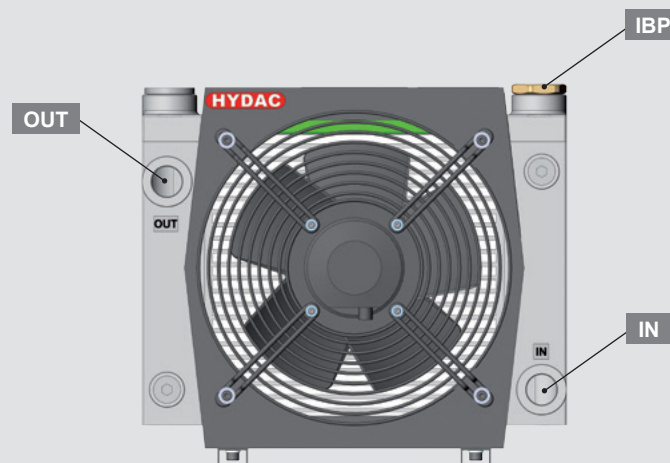
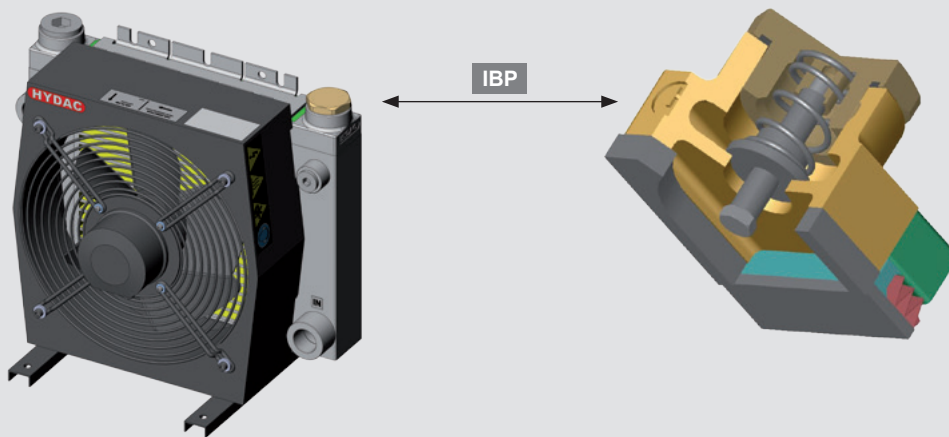

Model Type

Please check cooler compatibility in the table.

as accessory:

... / **IBP 2**

Opening pressure (see table of IBP versions)

IBP = Integrated bypass valve

as spare part:

IBP 2

Opening pressure (see table of IBP versions)

IBP = Integrated bypass valve

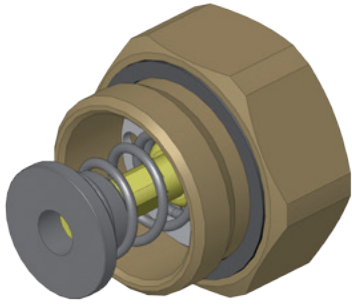

Integrated Temperature Bypass Valve IBT

Symbol

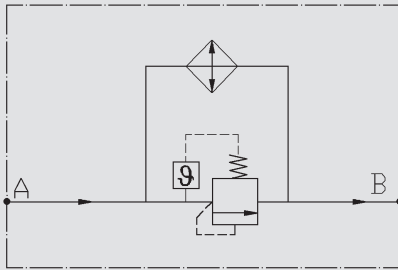

General

The IBT leaves the bypass channel open so that a part of the fluid bypasses the cooling element. Only when the fluid temperature reaches the required value, the IBT closes the bypass channel and the fluid is cooled down. So, a too low temperature of the fluid can be avoided i. e. at cold starts.

Note:

This valve requires a special cooling element with integrated bypass channel. Therefore, it cannot be retrofitted.

Operation Data

- Fixed setting temperature value
- Low pressure drop
- Works in any position
- Maintenance-free

IBT version	Available closing temperatures	Available opening pressure
IBT 25-x	25 °C	x = 2/3 bar
IBT 45-x	45 °C	x = 2/3/4/6 bar
IBT 50-x	50 °C	x = 2/3 bar
IBT 55-2	55 °C	2 bar
IBT 60-x	60 °C	x = 2 or 3 bar
IBT 65-2	65 °C	2 bar
IBT 75-2	75 °C	2 bar
IBT 80-2	80 °C	2 bar

Installation

Inlet port is always placed on the tank where the IBT is assembled.

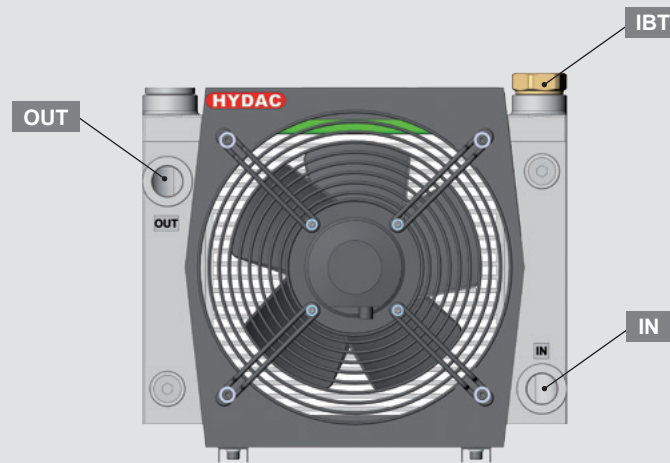
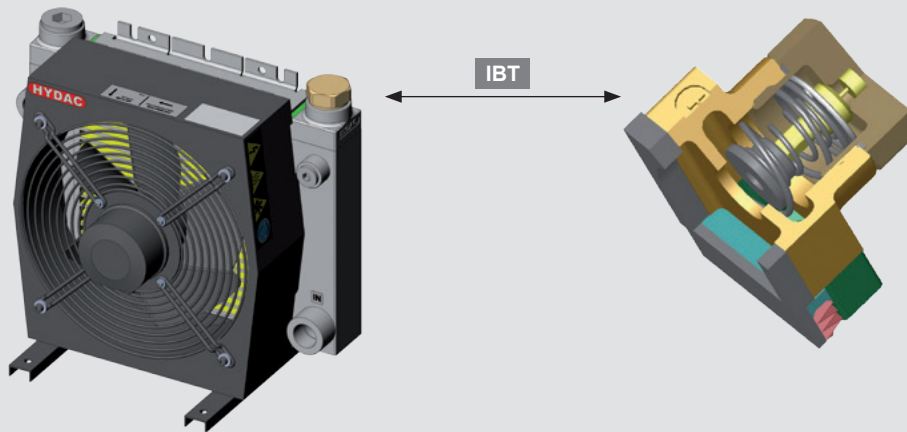

Model Type

Please check cooler compatibility in the table.

as accessory:

... / **IBT 45 - 2**

Opening pressure: 2, 3, 4 or 6 bar

Temperature at which IBT closes the bypass
(see table of IBT versions)

IBT = thermostatic bypass valve

as spare part:

IBT 45 - 2

Opening pressure: 2, 3, 4 or 6 bar

Temperature at which IBT closes the bypass
(see table of IBT versions)

IBT = thermostatic bypass valve

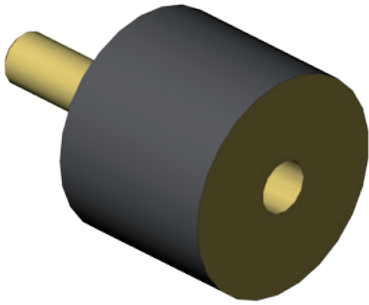

Vibration Absorbers GP

General

GP are rubber elements that are mounted between the cooler and the ground to absorb vibrations.

Operation Data

- Material: NR
- Hardness: 57 +/- 5 Sh

Cooler type	Dimensions
AC-LN 1-3 ACA-LN 2-3	
OK-ELC1-7	
OK-ELH 6 AC-LNH 8	
AC-LN 4-8 ACA-LN 4-6	
OSCA 1-3	
OK-ELH 7 AC-LNH 9	
ACA-LN 7-11	
AC-LN 9-11	
AC-LNH 10-11	
AC-LN 12-14	

Mounting

GP Mounting Kit

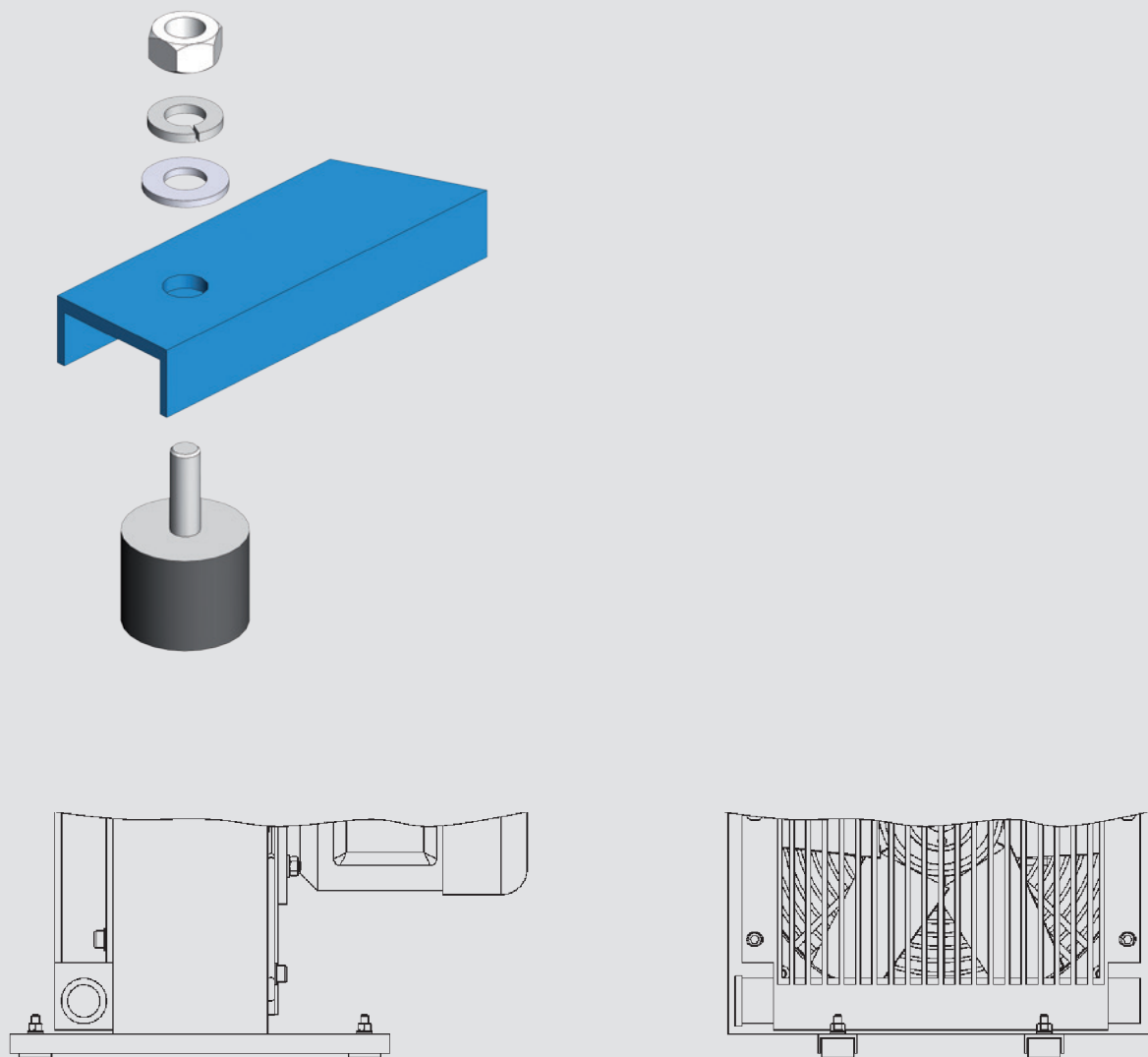

Model Type

Please check cooler compatibility in the table.

as accessory:

... / **GP**

GP = Vibration absorber

as spare part:

GP (AC-LN...)

Cooler / connection dimension

GP = Vibration absorber

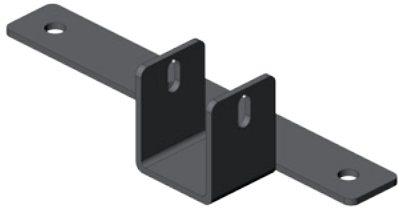

Feet

General

OK-ELD and OK-ELH models are not equipped with feet as standard. For these series feet are optional available.

Mounting

The foot has to be mounted using a screw already existing in the cooler (fixing the element to the housing) plus an additional screw supplied with the foot.

Feet Mounting Kit

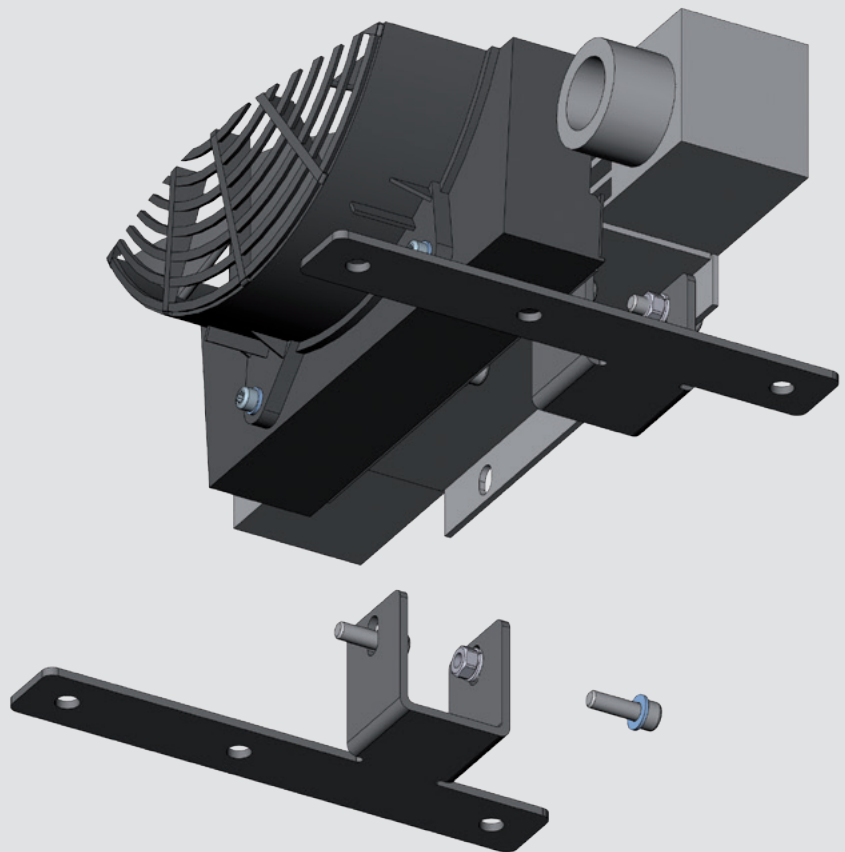

Dimensions

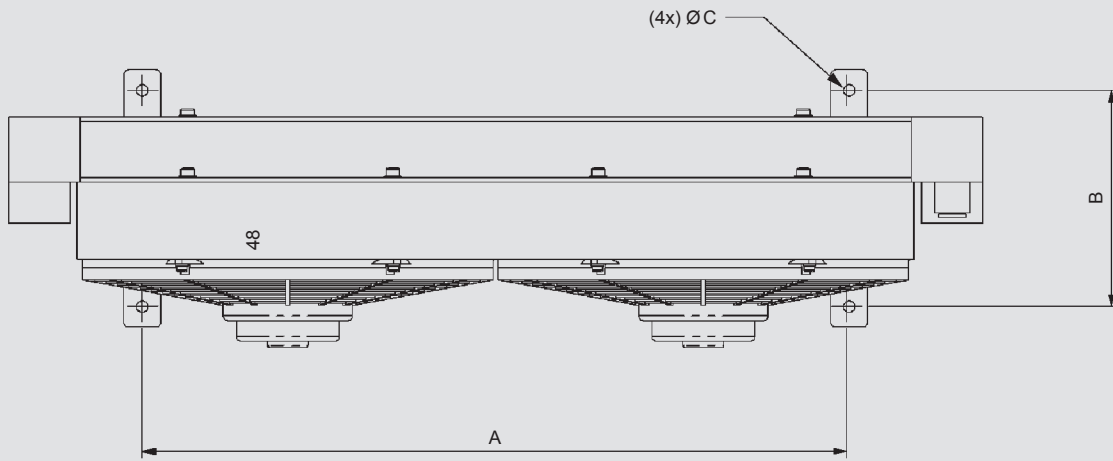

OK-ELD 1-6

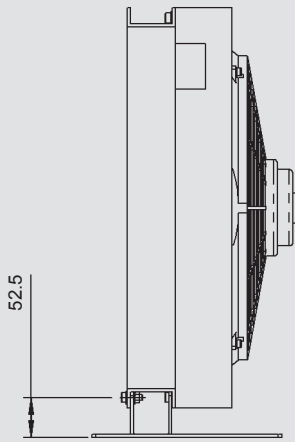

[mm]	A	B	C
OK-ELD 1	265	210	11
OK-ELD 2	249	210	11
OK-ELD 3	289	210	11
OK-ELD 4	389	210	11
OK-ELD 4.5	342	210	9
OK-ELD 5	599	210	11
OK-ELD 6	689	210	11

OK-ELH 2-5

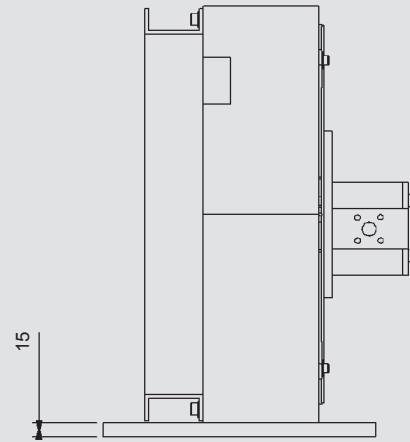

[mm]	A	B	C
OK-ELH 2	160	255	9
OK-ELH 3	240	255	9
OK-ELH 4	255	255	9
OK-ELH 5	255	255	9

Model Type

Please check cooler compatibility in the table.

as accessory:

... / **FU**

FU = Feet

as spare part:

FU (OK-ELD ...)

Cooler / dimensions

FU = Feet

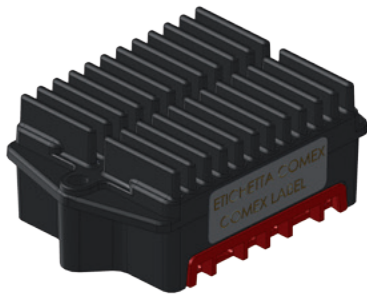

Electronic Speed Control ESC

Symbol

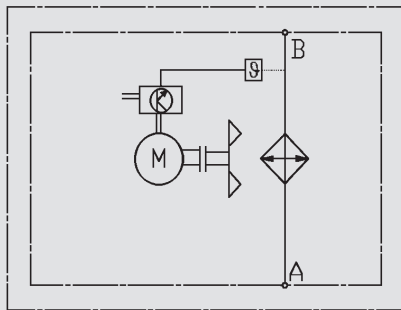

General

The ESC for DC coolers (OK-ELD series) controls the fan speed depending on the fluid temperature.

- Saves electric consumption
- Constant fluid temperature at the outlet
- Useful for multi-fan coolers
- Optional: Reverse function for heat exchanger cleaning

Operation Data

Operating temperature	-20 °C/+85 °C
Storage temperature	-40 °C/+95 °C
Operating voltage	12V DC or 24V DC
Current limit	35 A
Max. operating current in continuous working	30 A for standard models 25 A for reverse rotation models
Life time	200,000 cycles
Protection class	IP67
Electromagnetic compatibility	Conform to: 2004/108/EC 95/54/EC EN61000-6-3
Protection features	Electronics protected against load dump, reverse polarity, fan block, Electro Static Discharge (ESD). (A fuse is necessary and must be suitable for the input current of the fan used.)
Fan control options	1) Thermostat ON-OFF 2) NTC (temperature sensors) 3) 0-10 V signal 4) PWM
Additional functions	Soft start included with starting current not over +10 % of the nominal current
Control method	Control type PWM
Optional	Reverse rotation, also in working cycles (see options)
Control option	From 2 to more fan in parallel (max 35 A total)

Options

STANDARD rotation:

ESC controls fan speed proportionally with the fluid temperature.

REVERSE rotation 1 (Rev1):

Standard + reverse rotation

The reverse rotation starts as soon as the fan stops the normal rotation due to low temperature.

REVERSE rotation 2 (Rev 2):

Standard + reverse rotation (cycle)

The reverse rotation starts in a preset cycle, independent of the fluid temperature.

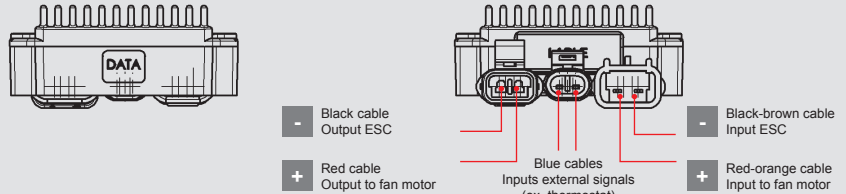
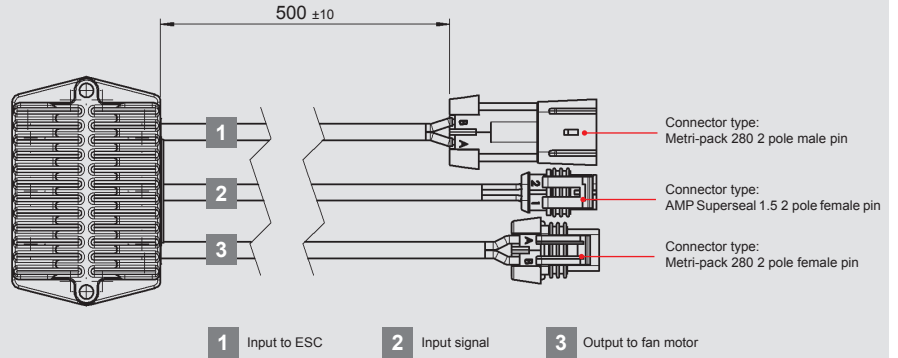

Mounting

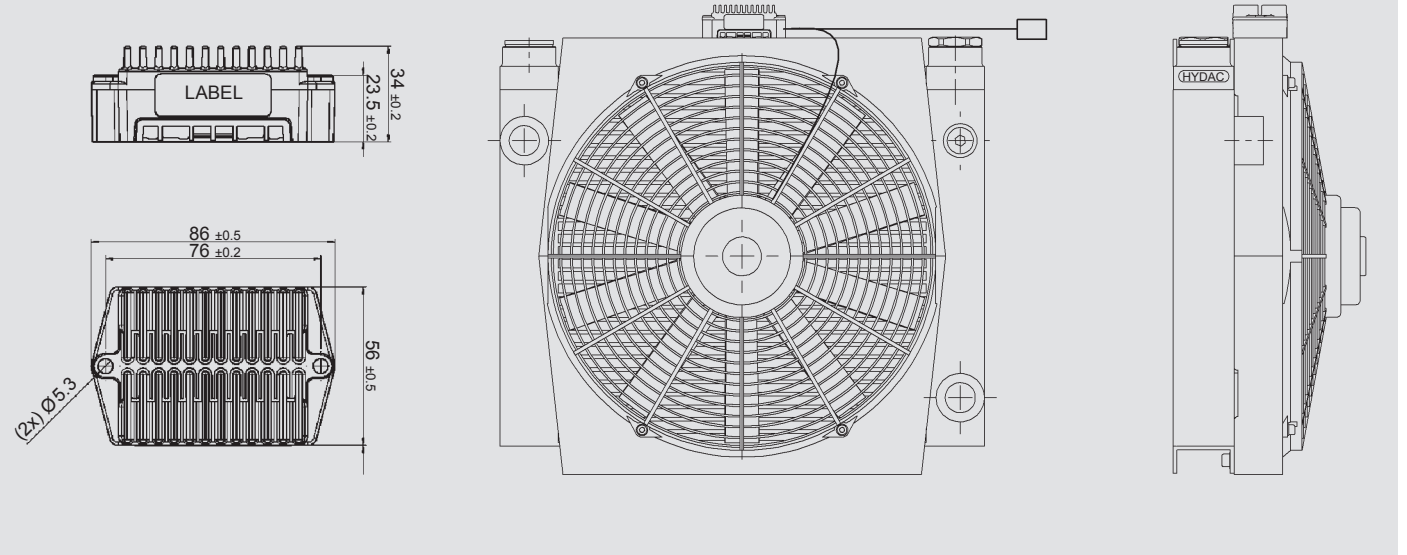

Model Type

Please check cooler compatibility in the table.

as accessory:

... / **ESC 40-60 (REV1 or REV2)**

- ESC option
- Operating temperature range
- ESC = Electronic Speed Control

as spare part:

ESC 40-60 (REV1 or REV2)

- ESC option
- Operating temperature range
- ESC = Electronic Speed Control

For information about temperature settings and cycles please contact technical sales department.

Element Protection Grid

LFG/LFM/LS

General

Protective grid mounted in front of the element to protect the element from stones, sand, leaves, dust and any other external agent that can clog the air side of element.

Only for sucking version of coolers available.

LFG

Protective grid with a metal mesh to filter the air and prevent element clogging from sand, leaves, dust and small stones.

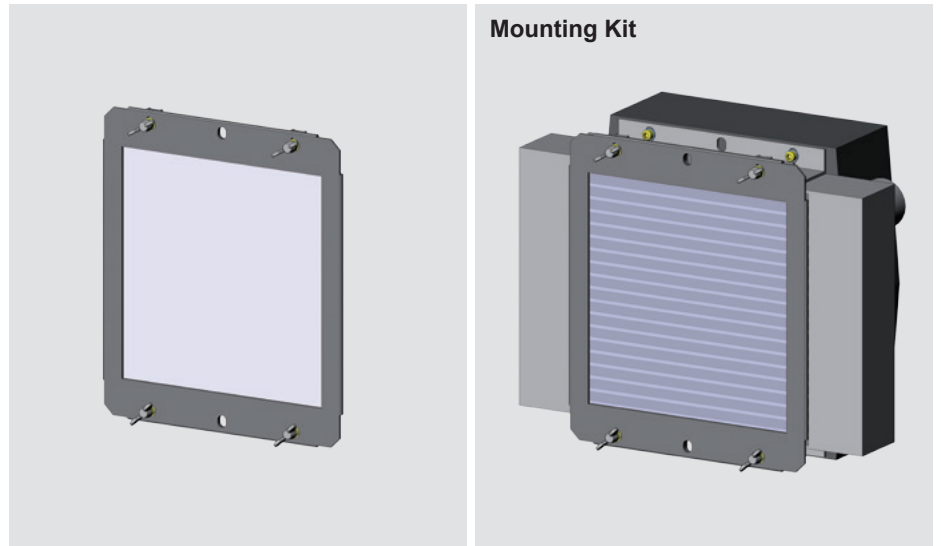

LFM

Protective grid equipped with filter element to filter dirty air across air side of the element.

The filter element can be exchanged easily.

Used to filter air from small particles of sand, dust and can offer protection against stones.

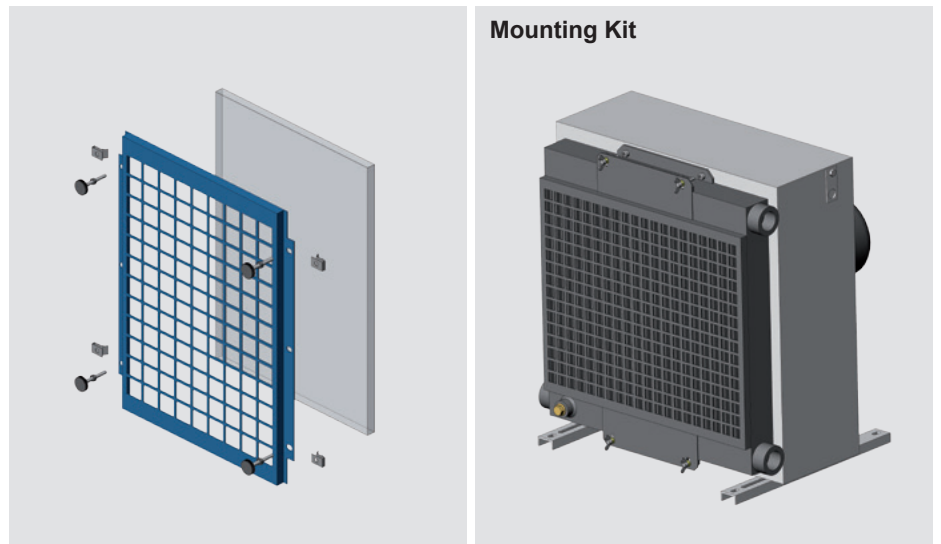

LS

Protective grid against stones.

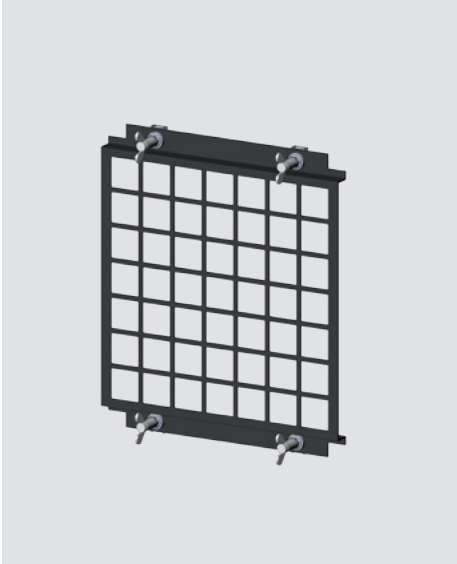

Mounting Kit

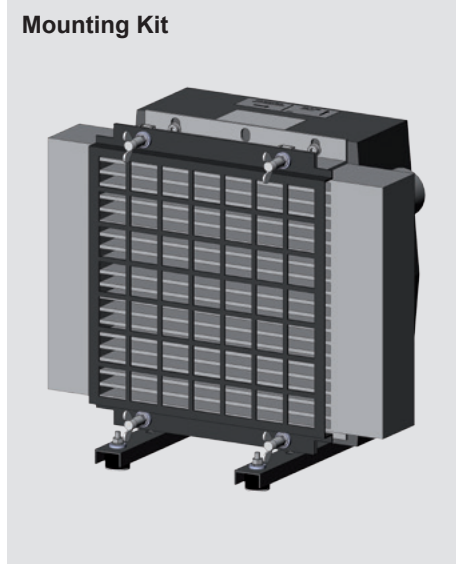

Model Type

Please check cooler compatibility in the table.

as accessory:

... / LFG

LFM = Air filter mat
LFG = Air filter grid
LS = Protection grid against stones

as spare part:

LFG (AC-LN...)

Cooler
LFM = Air filter mat
LFG = Air filter grid
LS = Protection grid against stones

Note

The information in this brochure relates to the operating conditions.

For applications and operating conditions not described, please contact the relevant technical department.

Subject to technical modifications.



HYDAC COOLING GMBH

Industriegebiet
66280 Sulzbach/Saar
Germany

Tel.: +49 6897 509-01
Fax: +49 6897 509-454

E-mail: cooling@hydac.com
Internet: www.hydac.com

**HYDAC AG
Mezzovico Branch**

Via Sceresca, Zona Industriale 3
6805 Mezzovico
Switzerland

Tel.: +41 91 9355-700
Fax: +41 91 9355-701

E-mail: info@hydac.ch
Internet: www.hydac.com

Plate Heat Exchangers



HYDAC HEX Sxxx



Hxxx-LIQUID

General

Plate heat exchangers are used wherever thermal energy (heat) has to be transferred from one fluid to another.

The advantage is that they can maintain the fluid temperature at a very low and stable level – depending on the temperature of the coolant.

Plate heat exchangers consist of a stack of stamped heat exchange plates which are either brazed together or bolted together in a frame with gaskets.

Medium flows in the channels between the plates where hot medium (which will be cooled) alternates with cold medium (which will be heated). The design of the plates induces the turbulent flow required for efficient heat transfer.

Brazed Plate Heat Exchangers HYDAC HEX Sxxx

The design and construction of the **brazed plate heat exchangers** are particularly compact and efficient. The heat transfer plates are made in stainless steel and are brazed with copper as standard. For use with aggressive media, nickel braze can also be used.

Copper brazed plate heat exchangers are pressure resistant up to 30 bar, nickel brazed up to 10 bar. Special models are however also suitable for higher pressures.

Gasketed Plate Heat Exchangers Hxxx-LIQUID

Gasketed plate heat exchangers are particularly suitable for large flows and high cooling capacities. The stack of heat transfer plates and gaskets is clamped together with bolts in a frame.

This means that the plate heat exchanger can also be dismantled for cleaning and maintenance. Furthermore it is possible to add more plates at a later date to achieve a higher capacity.

For applications with seawater, the plate heat exchangers can also be supplied with titanium heat transfer plates.

Various stamp designs can cater for heavily contaminated or high viscosity fluids to suit particular applications, or even if the temperature difference between the hot and cold medium is only minimal.

Safety heat exchangers with double-walled plates are used in situations where different media must be strictly isolated.

Function

Fluids flow in counterflow through the plate heat exchanger:

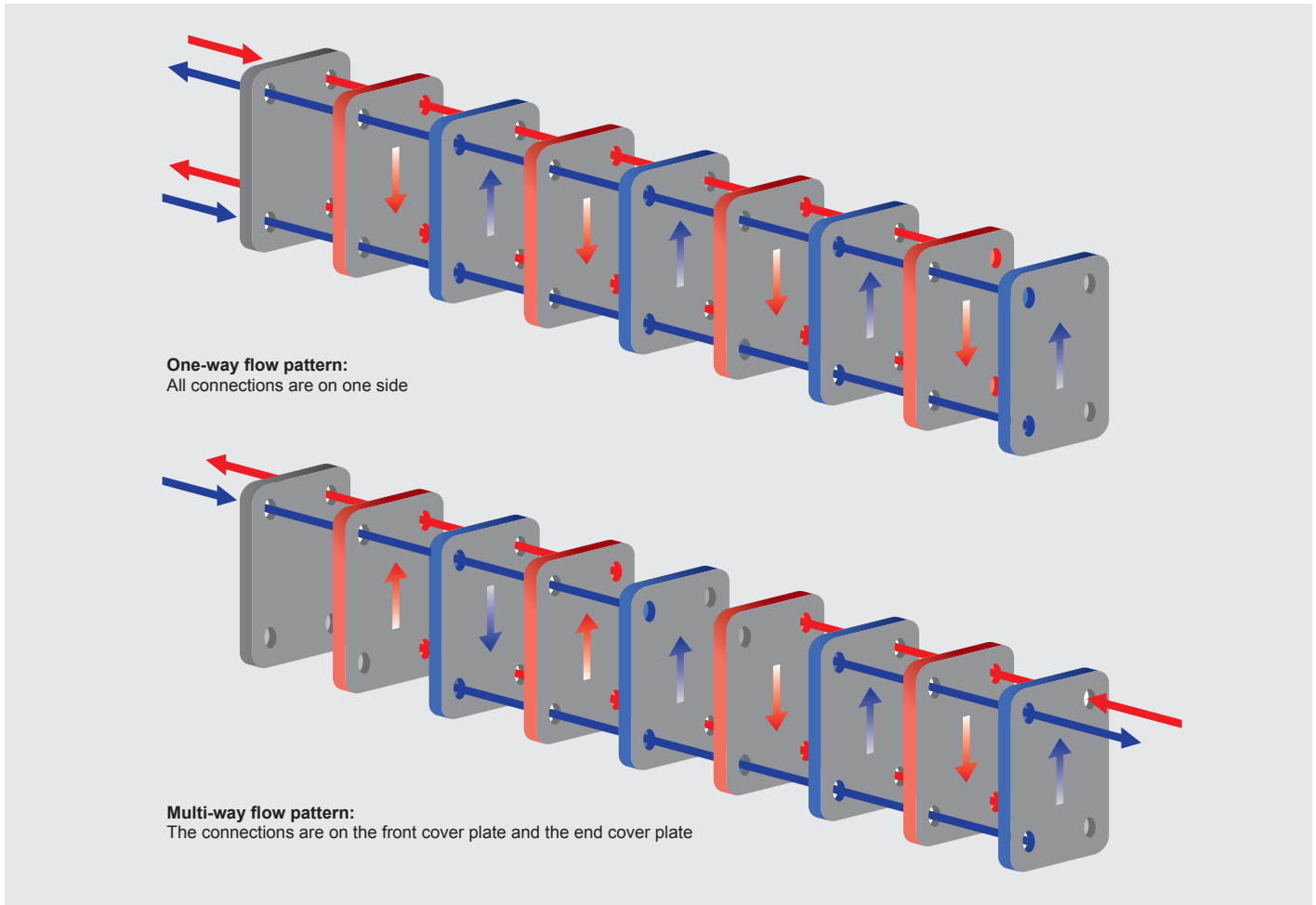

In counterflow, the hot medium is cooled more rapidly than in parallel flow because the cold medium flows in the opposite direction to the hot fluid.

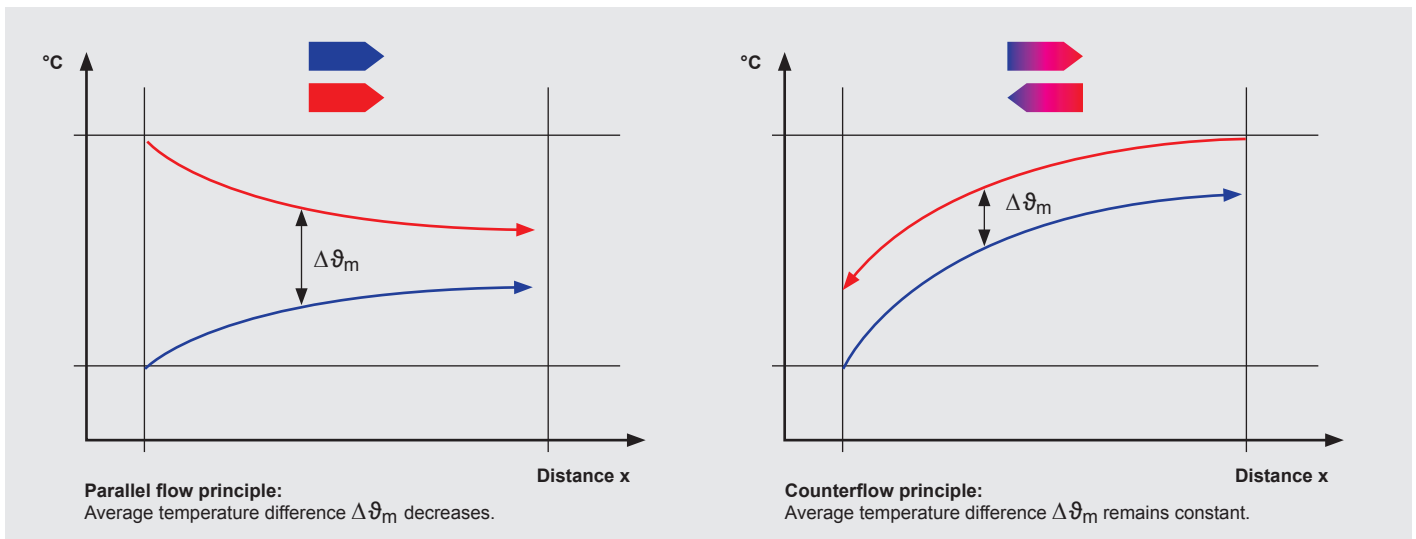

With **brazed plate heat exchangers** it is possible to reverse the inlet and outlet connections of a medium without adversely affecting the function. However, to guarantee the counterflow principle, the inlet and outlet of the other medium must also be changed. However, changing the cold and hot side is not recommended. The plate heat exchangers are designed to have hot fluid always flowing through the outer plate. If cold medium flows through, condensation could form on the outside of the heat exchanger.

With **gasketed plate heat exchangers** it is not possible to change the connections because of the more complex plate stamp pattern. In this case the connections can be selected before manufacture of the plate heat exchanger. Please consult our technical sales department.

Application Field

A plate heat exchanger can be used wherever there should be heat transfer between two media.

Typical applications are:

- Hydraulic systems
- Presses
- Lubrication systems
- Test rigs
- Motors/engines

Sectional View

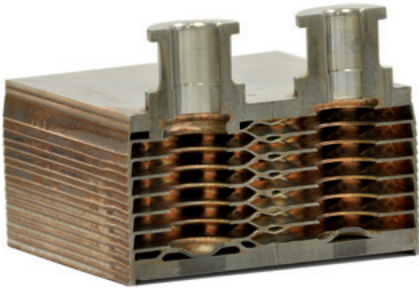

Cross-section of a brazed plate heat exchanger

Cooling Capacity

The maximum cooling capacity of a plate heat exchanger depends on several factors:

- the inlet temperature of the hot and cold medium
- the flow rate of the hot and cold medium
- the media used.

Sizing Program

The sizing program for **brazed plate heat exchangers** helps you to select the right size and number of plates.

Please ask for the latest version from the technical sales department.

Type	Plate No.	Series	Parallel	Required heat load	Margin	Press. drop of side 1	Press. drop of side 2	Note
				kW	%	bar	bar	
HEX S400								No Solution
HEX S610	110	1	1	10,0	-1,6	0,01	0,03	
HEX S615	30	1	1	10,0	2,0	0,07	0,19	
HEX S522	30	1	1	10,0	30,7	0,01	0,06	
HEX S722	30	1	1	10,0	15,3	0,01	0,06	

PHE: **HEX S615** PDF Drawing

For **gasketed plate heat exchangers** please fill in the Specification Sheet in this brochure and send it to the technical sales department.

We will help you to find the appropriate plate heat exchanger for your specific application.



Brazed Plate Heat Exchangers HYDAC HEX Sxxx

Symbol

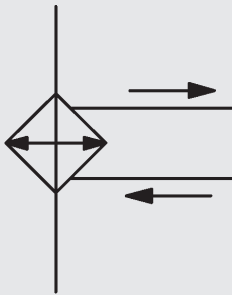

General

With plate heat exchangers, the heat from the fluid being cooled is transferred to a cooling fluid. The advantage is that they can maintain the fluid temperature at a very low and stable level – depending on the temperature of coolant. Brazed heat exchangers therefore ensure efficient heat transfer combined with compact dimensions and low weight.

Product Features

Brazed heat exchangers consist of a stack of stamped heat transfer plates with connections in stainless steel. The plates are vacuum brazed with copper or nickel.

The plates have smoothed edges and the end plate is provided with edge protection.

The special stamp pattern of the plates induces a turbulent flow which is necessary for optimum heat transfer and which in addition has a self-cleaning effect because the high level of wall friction reduces deposits on the surface.

Operating data

Plate material	Stainless steel 1.4401 (AISI 316)
Braze material	Copper (standard), nickel
Pressures	Copper braze: max. 30 bar (test pressure 45 bar) Nickel braze: max. 10 bar Other pressures on request
Media	<ul style="list-style-type: none"> ● Hydraulic oil, lubrication oil, rolling oil, engine oil ● HFC, HFA, HFD, pressure fluids ● Water, water glycol ● Refrigerant Use nickel-brazed plate heat exchangers with corrosive fluids: e.g. ammonia, sulphides and sulphates, deionised or demineralised water Other fluids on request
Temperature range	up to +200 °C (freezing point and boiling point must be taken into consideration)
Contamination	The quantity of particles in suspension should be less than 10 mg/l Particle size <0.6 mm (spherical) Thread-like particles cause a rapid rise in pressure drop
Water quality	The following ions are not corrosive under normal conditions: phosphate, nitrate, nitrite, manganese, sodium and potassium See table on water quality
Connections	Female thread (standard) Optional: male thread, soldered connection, SAE connection
Accessories	Installation: HYDAC clamping bands (standard), optional: bolts on the front plate or the end plate Insulation

Application Field

Cooling circuits operated using water, coolant, HFC operating fluid or oil.

Typical applications are:

- Machine tools
- Presses
- Injection moulding machines
- Motors/engines
- Test rigs
- Generators

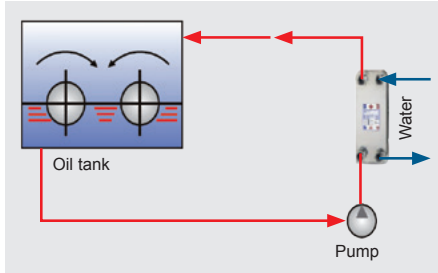

Oil cooling

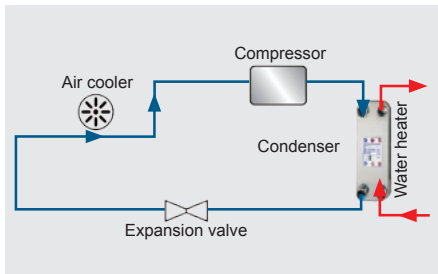

Heat pump

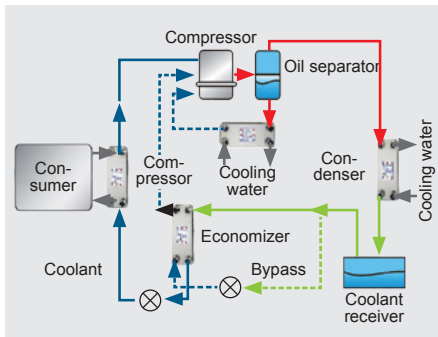

Chiller

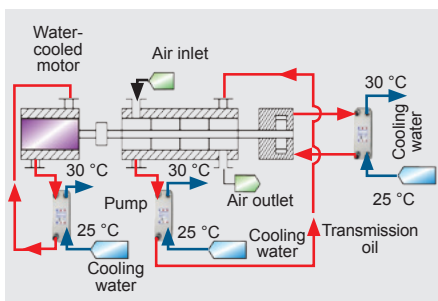

Vacuum pump

Model Type

HYDAC HEX S400 -10 -00NI / G3/4"

Size

HYDAC HEX S400
HYDAC HEX S610
HYDAC HEX S615
HYDAC HEX S522
HYDAC HEX S722
HYDAC HEX Z800

Other sizes on request

Number of plates

	10	14	20	30	40	50	60	70	80	90	100	120	150	160	180	190
HYDAC HEX S400	•	•	•	•	•											
HYDAC HEX S610	•		•	•	•	•	•	•	•	•	•	•				
HYDAC HEX S615	•		•	•	•	•	•	•	•	•	•	•				
HYDAC HEX S722			•	•	•	•	•	•	•	•	•	•	•	•	•	•
HYDAC HEX S522			•	•	•	•	•	•	•	•	•	•	•	•	•	•

Version with nickel braze (optional)

Connections (standard)

HYDAC HEX S400: 4 x G $\frac{3}{4}$ " female thread

HYDAC HEX S610 and HYDAC HEX S615: 4 x G1" female thread

HYDAC HEX S722: 4 x G1 $\frac{1}{2}$ " female thread

HYDAC HEX S522: 4 x G1 $\frac{1}{2}$ " female thread

Male threaded, soldered and SAE connections are also available as an option. The pipes must be connected so that connections are stress-free. Linear expansion and vibrations from the pipes to the heat exchanger must be avoided.

Water Quality

The following limits refer to copper-brazed plate heat exchangers and a water temperature of + 60°C:

Substances dissolved in water	Concentration (ppm)	Stainless steel	Copper
pH value	<6.0 6.0 – 9.0 >9.0	0 + +	0 + 0
Electrical conductivity	<10 [μ S/cm] 10 – 500 [μ S/cm] >500 [μ S/cm]	+ + +	0 + 0
Cl ⁻	<300	+	+
SO ₄ ⁻²	<50 50 – 300 >300	+ + 0	+ 0 0
CaCO ₃	<50	+	+
Fe	<0.3 >0.3	+ +	+ 0
NH ₃	<2 >2	+ +	+ 0
NO ₃	<100 >100	+ +	+ 0
S ⁻²		Not suitable	
SiO ₂	<30	+	+
NH ₄ ⁺	<0.1	+	+
Free chlorine	<0.1	+	+
CO ₃ ⁻²	<0.4	+	+
H ₂ S	<0.05 >0.05	+ +	+ 0

0: Corrosive

+: Suitable

For nickel-brazed versions, please contact the technical sales department.

Dimensions

HYDAC HEX S400

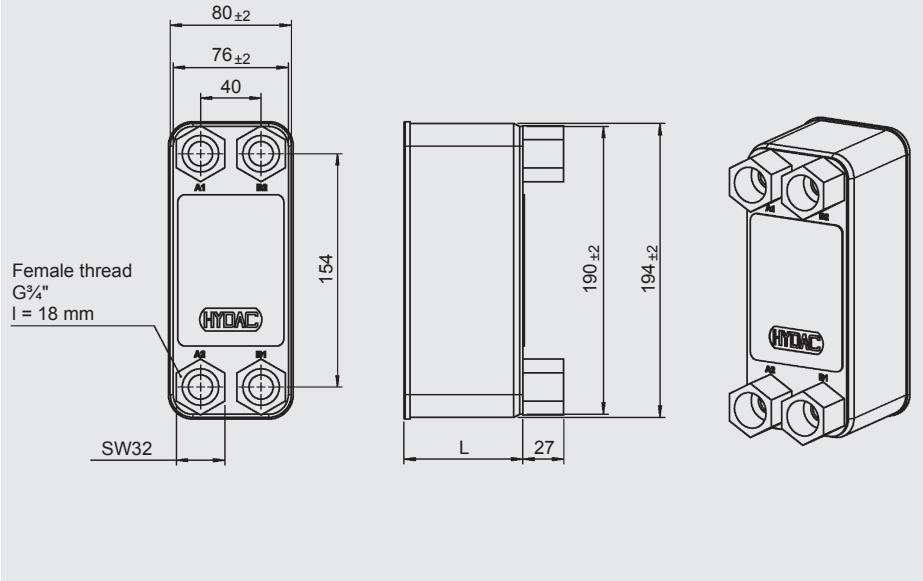
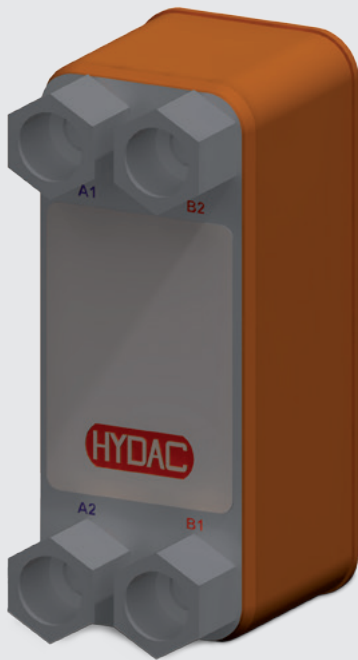

HYDAC Part No.	HYDAC Type Code	Dimension L [mm]	Weight [kg]
3455621	HYDAC HEX S400-10-00/G3/4"	33	1.3
3383847	HYDAC HEX S400-14-00/G3/4"	42	1.5
3455623	HYDAC HEX S400-20-00/G3/4"	55	1.8
3399435	HYDAC HEX S400-30-00/G3/4"	78	2.3
3455655	HYDAC HEX S400-40-00/G3/4"	101	2.8

HYDAC HEX S610

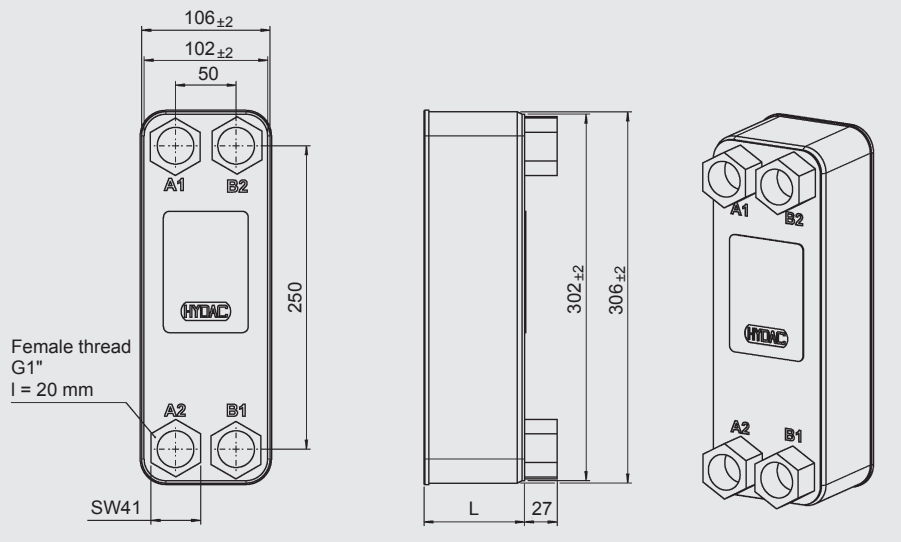

HYDAC Part No.	HYDAC Type Code	Dimension L [mm]	Weight [kg]
3366746	HYDAC HEX S610-10-00/G1"	34	2.5
3361012	HYDAC HEX S610-20-00/G1"	58	4.2
3366754	HYDAC HEX S610-30-00/G1"	82	5.5
3366759	HYDAC HEX S610-40-00/G1"	106	6.9
3366760	HYDAC HEX S610-50-00/G1"	130	8.25
3366761	HYDAC HEX S610-60-00/G1"	154	9.6
3366762	HYDAC HEX S610-70-00/G1"	178	10.9
3527300	HYDAC HEX S610-80-00/G1"	202	11.0
3366763	HYDAC HEX S610-100-00/G1"	250	14.2
3366764	HYDAC HEX S610-120-00/G1"	298	16.6

HYDAC HEX S615

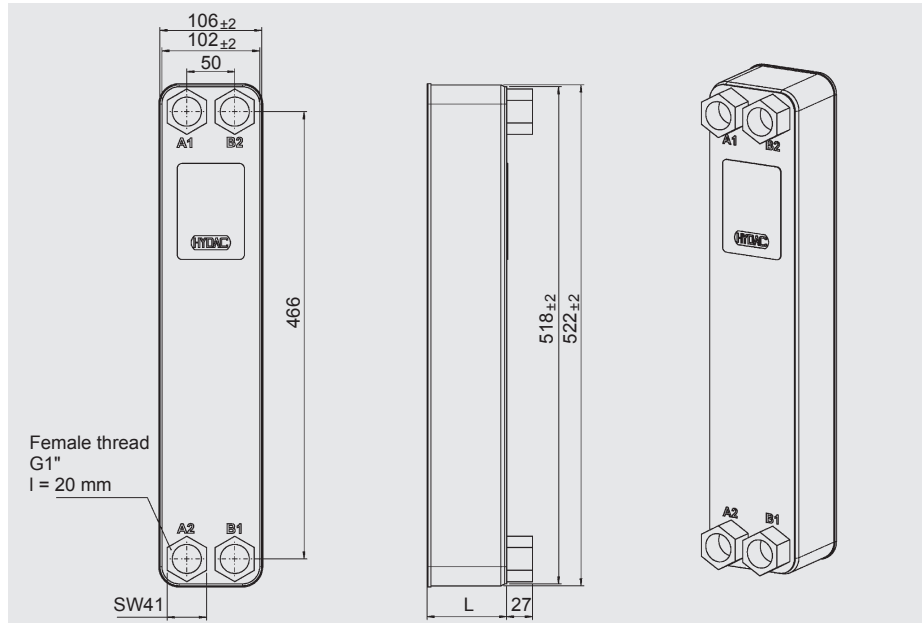
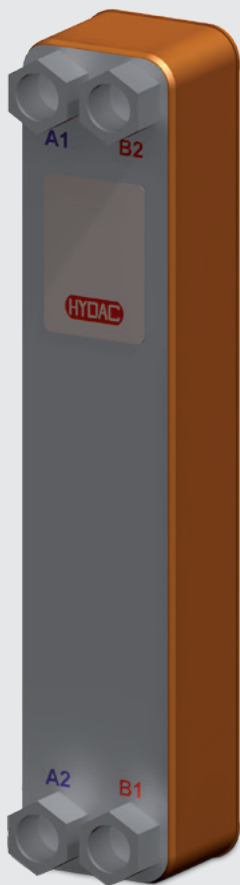

HYDAC Part No.	HYDAC Type Code	Dimension L [mm]	Weight [kg]
3366787	HYDAC HEX S615-10-00/G1"	34	5.3
3366788	HYDAC HEX S615-20-00/G1"	58	7.5
3366790	HYDAC HEX S615-30-00/G1"	82	9.7
3366792	HYDAC HEX S615-40-00/G1"	106	11.9
3366793	HYDAC HEX S615-50-00/G1"	130	14.1
3366794	HYDAC HEX S615-60-00/G1"	154	16.3
3366815	HYDAC HEX S615-80-00/G1"	202	20.7
3383853	HYDAC HEX S615-100-00/G1"	250	25.7

HYDAC HEX S722

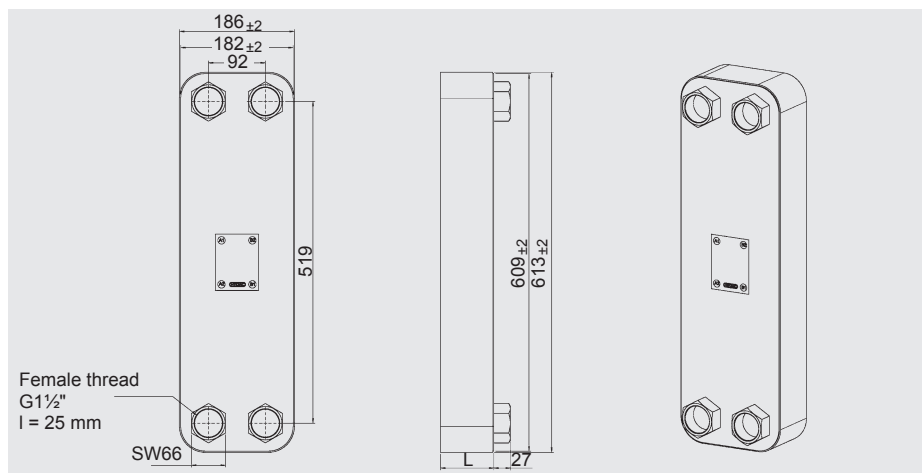
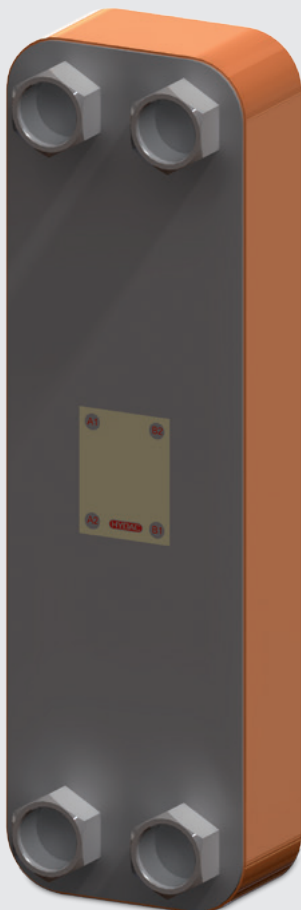

HYDAC Part No.	HYDAC Type Code	Dimension L [mm]	Weight [kg]
3457465	HYDAC HEX S722-20-00/G1 1/2"	62	15.3
3457473	HYDAC HEX S722-30-00/G1 1/2"	86	19.4
3457474	HYDAC HEX S722-40-00/G1 1/2"	110	23.5
3457486	HYDAC HEX S722-50-00/G1 1/2"	134	27.6
3457489	HYDAC HEX S722-60-00/G1 1/2"	158	31.7
3457490	HYDAC HEX S722-70-00/G1 1/2"	182	35.8
3457491	HYDAC HEX S722-80-00/G1 1/2"	206	40.0
3457493	HYDAC HEX S722-90-00/G1 1/2"	230	44.0
3457494	HYDAC HEX S722-100-00/G1 1/2"	254	48.0
3457495	HYDAC HEX S722-120-00/G1 1/2"	302	53.4
3457496	HYDAC HEX S722-150-00/G1 1/2"	374	69.0
3673112	HYDAC HEX S722-160-00/G1 1/2"	394	72.7
3463069	HYDAC HEX S722-190-00/G1 1/2"	470	84.8

HYDAC HEX S522

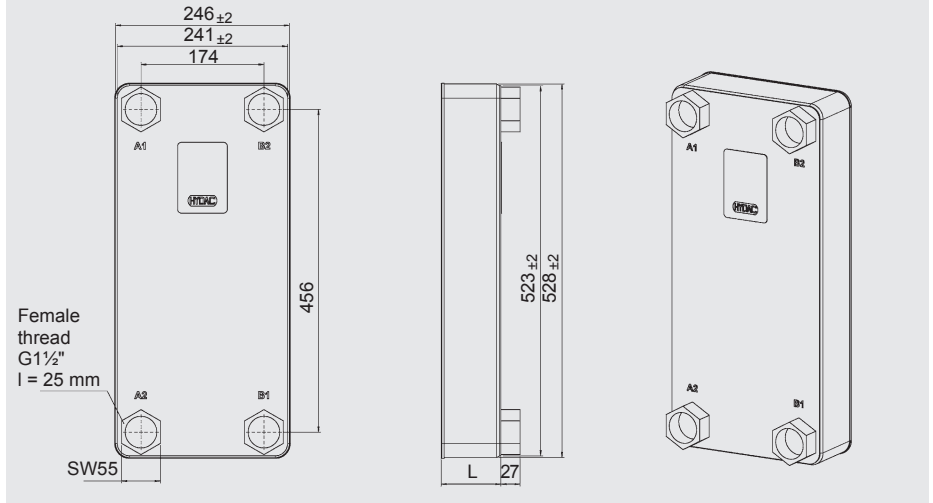
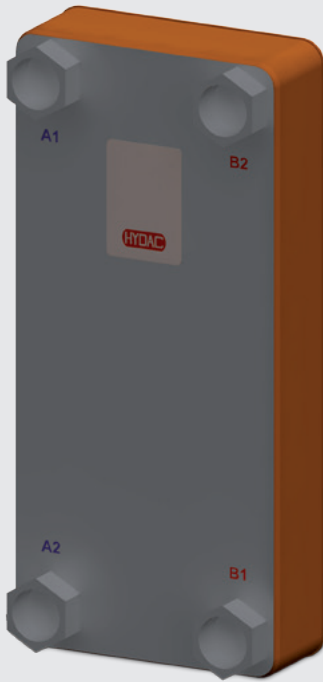

HYDAC Part No.	HYDAC Type Code	Dimension L [mm]	Weight [kg]
3383854	HYDAC HEX S522-20-00/G1 1/2"	60	17.6
3383906	HYDAC HEX S522-30-00/G1 1/2"	84	22.8
3383908	HYDAC HEX S522-40-00/G1 1/2"	108	28.0
3383909	HYDAC HEX S522-50-00/G1 1/2"	132	31.2
3383910	HYDAC HEX S522-60-00/G1 1/2"	156	38.4
3383911	HYDAC HEX S522-70-00/G1 1/2"	180	43.6
3383913	HYDAC HEX S522-80-00/G1 1/2"	204	48.8
3383914	HYDAC HEX S522-100-00/G1 1/2"	252	59.2
3651724	HYDAC HEX S522-110-00/G1 1/2"	276	60.8
3383925	HYDAC HEX S522-120-00/G1 1/2"	300	69.6
3383926	HYDAC HEX S522-150-00/G1 1/2"	372	85.2
3738950	HYDAC HEX S522-160-00/G1 1/2"	396	84.8
3383927	HYDAC HEX S522-190-00/G1 1/2"	468	106.0

HYDAC HEX Z800

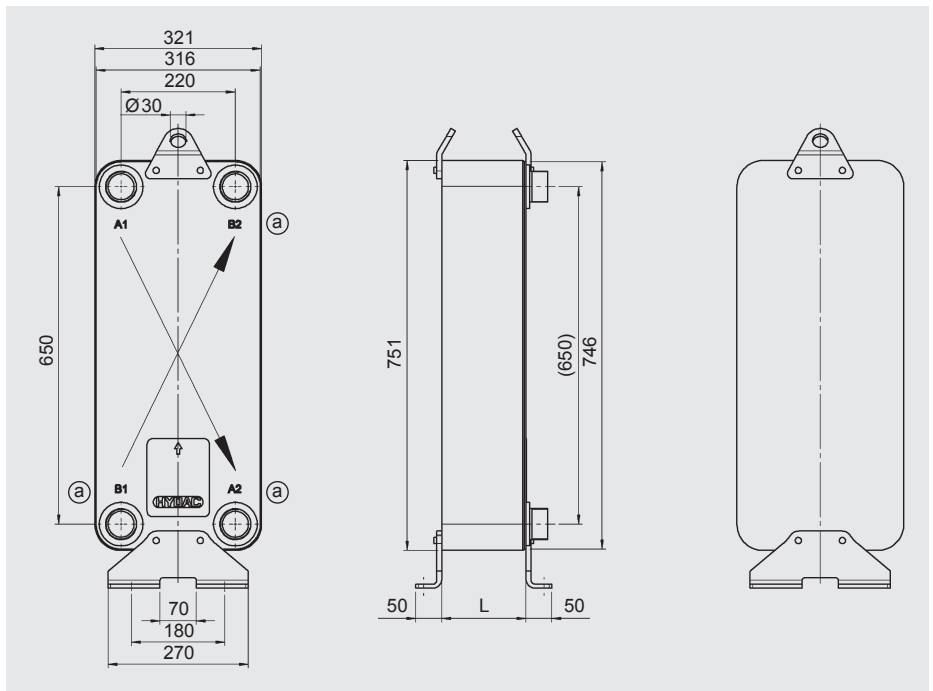
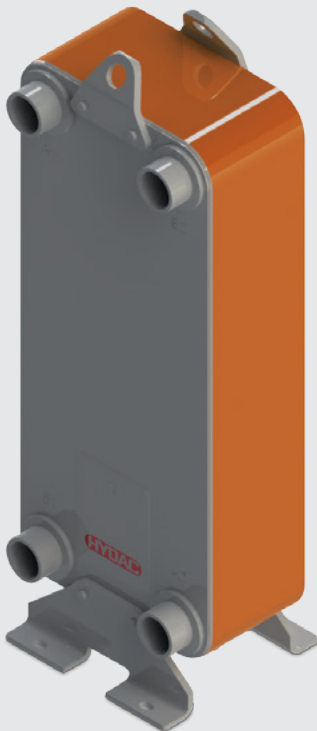

Special size for high cooling capacities and large volumes:

- Diagonal flow pattern
- Connections: threaded bolts with female or male threads, flange, soldered or SAE connections

Installation

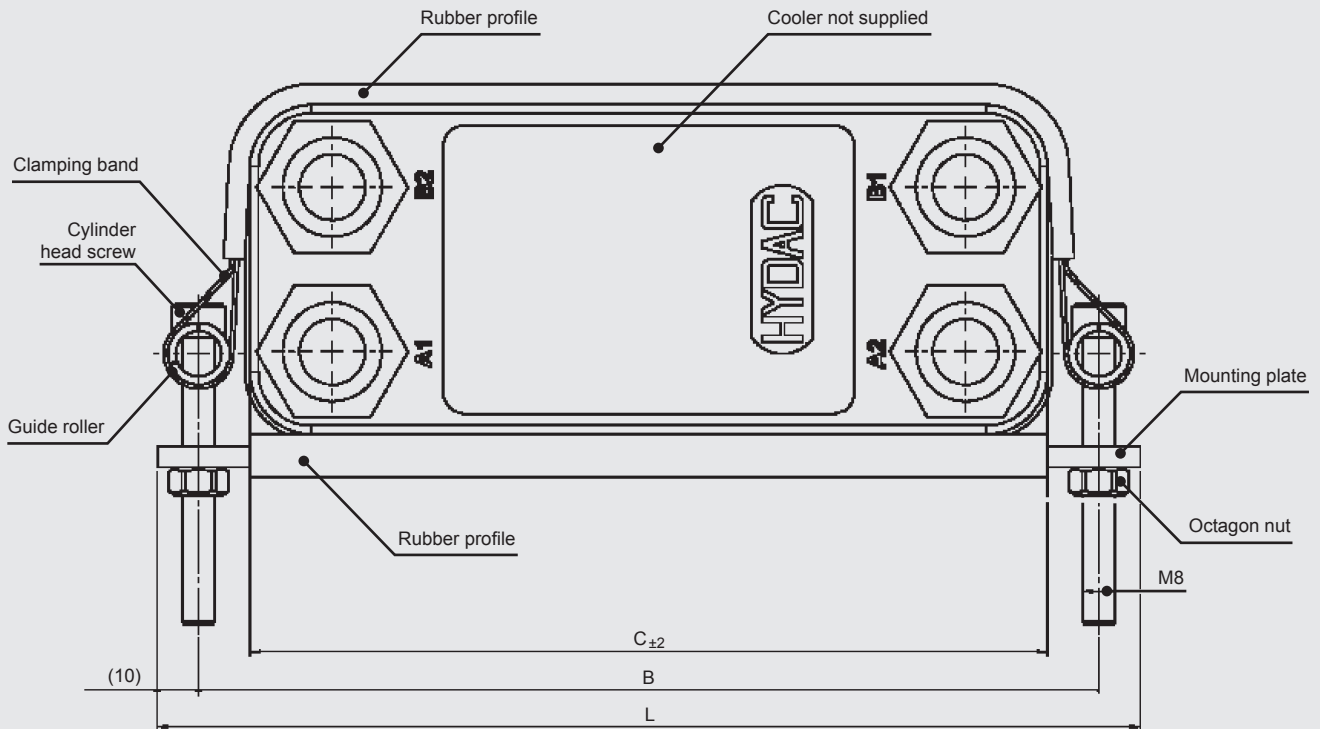

HYDAC Part No.	HYDAC Type Code	c [mm]	d [mm]	l [mm]	b [mm]
3092917	HYDAC HEX S400	194	80	239	219
3014028	HYDAC HEX S610	306	106	351	331
3014029	HYDAC HEX S615	522	106	566	546
3343306	HYDAC HEX S522	528	246	573	553
3013884	HYDAC HEX S722	613	186	658	638

Please note:

For mounting heat exchangers with 60 plates and above, two clamps are recommended.



Symbol

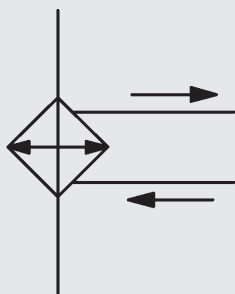

General

With plate heat exchangers, the heat from the fluid being cooled is transferred to a cooling fluid. The advantage is that they can maintain the fluid temperature at a very low and stable level – depending on the temperature of coolant.

Gasketed plate heat exchangers are particularly suitable for large flows and high cooling capacities and are therefore a useful supplement to the brazed range.

Product Features

Gasketed plate heat exchangers consist of a stack of individually stamped heat transfer plates and gaskets. The plate stack is clamped using bolts in a frame consisting of a fixed cover and a moveable cover. The advantage is that the plate heat exchanger can also be dismantled for cleaning and maintenance. Furthermore it is possible to add more plates at a later date to achieve a higher capacity.

There are several sizes with varying numbers of plates and different stamp designs available to cover the capacity range. In this way they can cater for heavily contaminated or high viscosity fluids, or even if the temperature difference between the hot and cold medium is only minimal.

Gasketed Plate Heat Exchangers

Hxxx-LIQUID

Operating Data

Plate material	Stainless steel 1.4401 (AISI 316), 1.4306 (AISI 304) SMO Titanium
Plate thickness	0.4 – 0.6 mm
Seals	NBR (HT) EPDM Viton
Connections	Threaded pipe, male Flange (up to DN300) Note: The connection interface can only be altered before manufacture.
Paint colour	RAL 5010 Corrosion class: C2L Other paint finishes on request
Media	Hydraulic oil, lubrication oil, rolling oil, engine oil HFC, HFA, HFD, operating fluids water, water-glycol, seawater (with titanium plates) Limited possibility: steam applications
Operating temperature	up to 140 °C
Pressure ranges	10 bar, 16 bar, 25 bar Note: Pressure surges must be avoided
Flow rate	up to 2,000 m³/h
Cooling capacity	up to 30,000 kW (dependent on the inlet temperature of the media and the flow rate)
Contamination	The level of particles in suspension should be less than 10 mg/l Particle size: <0.6 mm (spherical); thread-like particles cause a rapid rise in pressure drop.
Water quality	See table on water quality
Options	Safety heat exchanger Dual unit with change-over valve Insulation

Depending on the individual situation, special models using higher grade materials are available, e.g. titanium plates are used for seawater applications.

Application Field

Cooling circuits in counterflow which are operated using water, coolant, HFC operating fluids or oil. For applications using other fluids please contact the specialist department.

Typical applications are:

- Hydraulic systems
- Presses
- Lubrication systems
- Test rigs
- Motors/engines

Model Type

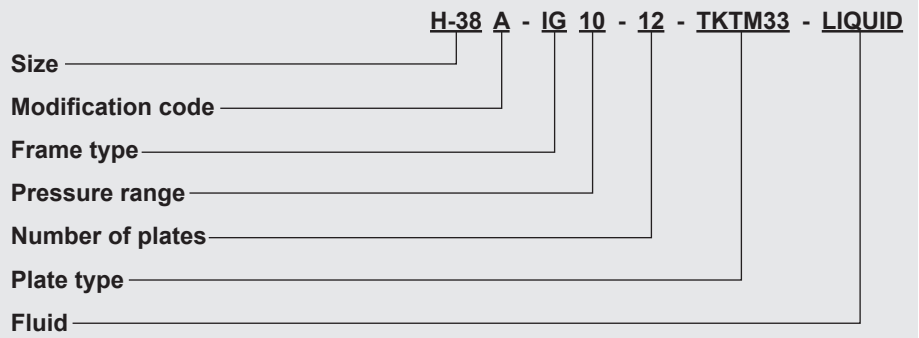

Water Quality

Substances dissolved in water	Concentration of substance in mg/l	Notes below relate to 1.4401
Aluminium (Al) – in solution	<0.2	A
	>0.2	A
Ammonia NH ₃	<2	A
	2 – 20	A
	>20	A
Chloride Cl ⁻ (max. +60 °C)	<250	A
	>250	B
Electrical conductivity	<10 µ S/cm	A
	10 – 500 µ S/cm	A
	>500 µ S/cm	A
Iron Fe – in solution	<0.2	A
	>0.2	A
Free aggressive carbonic acid CO ₂	<5	A
	5 – 20	A
	>20	A
Total hardness	4.0 – 8.5 °dH	A
Glycol percentage	<20 %	A
	20 – 50 %	A
	>50 %	A
HCO ₃ ⁻ SO ₄ ⁻²	<1.0	A
	>1.0	A
Hydrogen carbonate HCO ₃ ⁻	<70	A
	70 – 300	A
	>300	A
Manganese Mn – in solution	<0.1	A
	>0.1	A
Nitrate – in solution NO ₃	<100	A
	>100	A
pH value	<6	B
	6.0 – 7.5	A / B
	7.5 – 9.0	A
Sulphate SO ₄ ⁻²	>9	A
	<70	A
	70 – 300	A
Sulphite SO ₃ / Free chlorine gas Cl ₂	>300	C
	<1	A
	1 – 5	A
Hydrogen sulphide (H ₂ S)	>5	A / B
	<0.05	A
	>0.05	A

A = under normal circumstances, good resistance
 B = danger of corrosion, especially if several B substances are present
 C = not suitable

Chloride content	Max. wall surface temperature			
	60 °C	80 °C	120 °C	130 °C
≤10 ppm	W 1.4301	W 1.4301	W 1.4301	W 1.4401
≤25 ppm	W 1.4301	W 1.4301	W 1.4401	W 1.4401
≤50 ppm	W 1.4301	W 1.4401	W 1.4401	Ti
≤80 ppm	W 1.4401	W 1.4401	W 1.4401	Ti
≤150 ppm	W 1.4401	W 1.4401	Ti	Ti
≤300 ppm	W 1.4401	Ti	Ti	Ti
>300 ppm	Ti	Ti	Ti	Ti

Note: This table is not exhaustive and serves only as a guide.

Dimensions

The dimensions can vary according to the frame type. Gasketed plate heat exchangers are calculated individually according to the application. You will find the relevant frame length L on the data sheet for your calculation.

H8 / H16

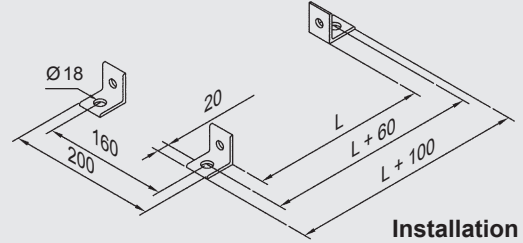
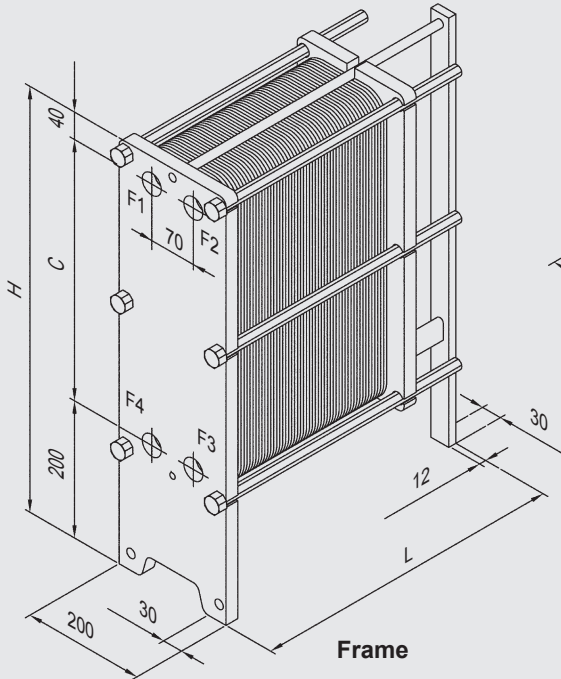

Installation

Pressure ranges: 16 bar, 25 bar

Size	Dimension H	Dimension C
H8	621 mm	381 mm
H16	896 mm	656 mm

H14 / H28 / H40

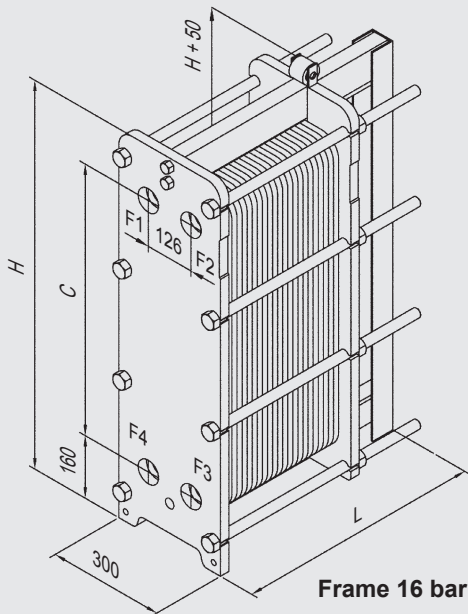

Frame 16 bar

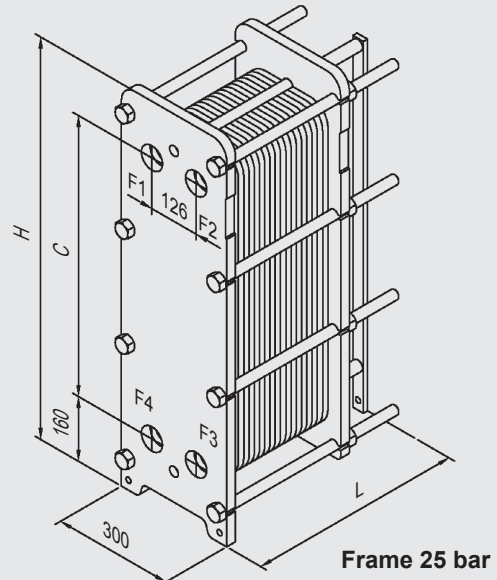

Frame 25 bar

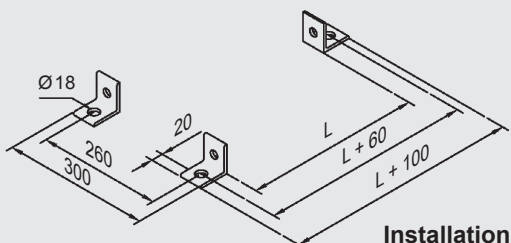

Installation

Pressure ranges: 16 bar, 25 bar

Size	Dimension H	Dimension C
H14	694 mm	394 mm
H28	994 mm	694 mm
H40	1,194 mm	894 mm

H18 / H38 / H62

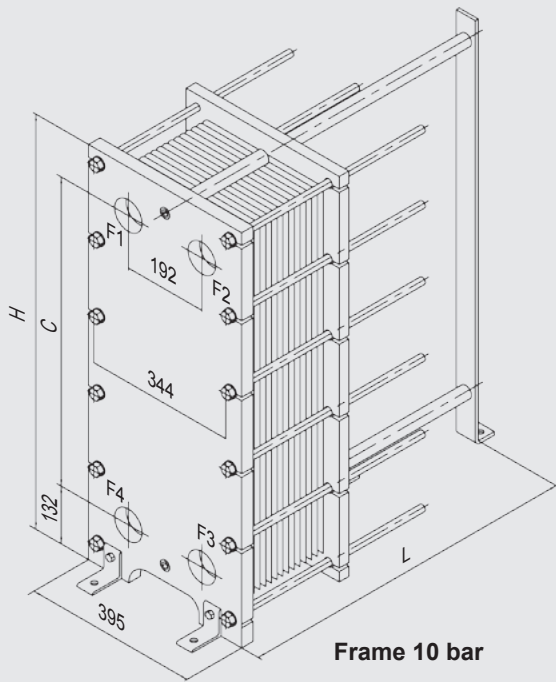

Frame 10 bar

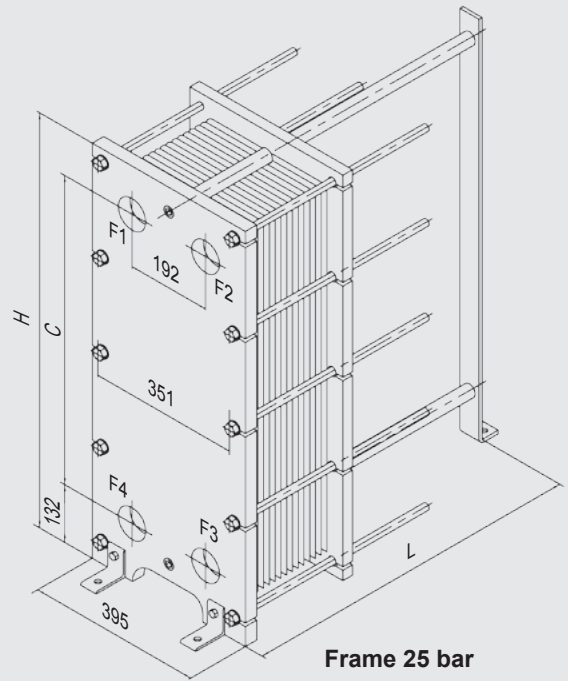

Frame 25 bar

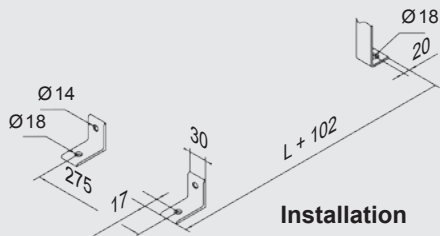

Installation

Pressure ranges: 10 bar, 16 bar

Size	Dimension H	Dimension C
H18	626 mm	380 mm
H38	946 mm	700 mm
H62	1,296 mm	1,050 mm

H42 / H44 / H94 / H128

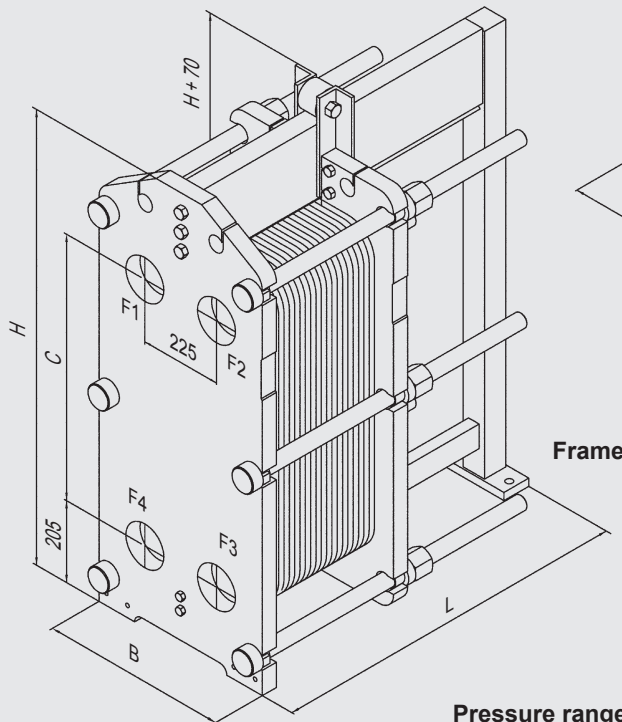

Frame

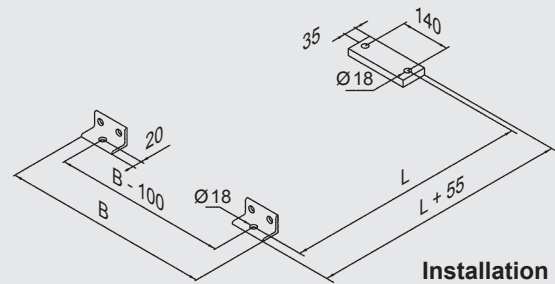

Installation

Pressure ranges: 10 bar, 16 bar, 25 bar

Size	Dimension H	Dimension C	Dimension B
H42 / H44	1,238 mm	719 mm	495 mm
H94	1,884 mm	1,365 mm	480 mm
H128	2,291 mm	1,771 mm	480 mm

H74 / H102

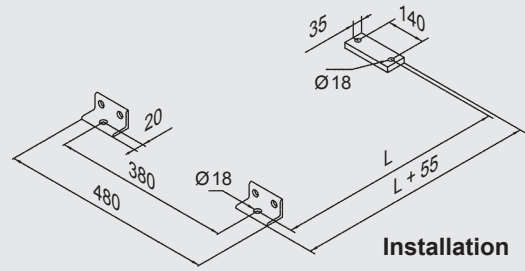
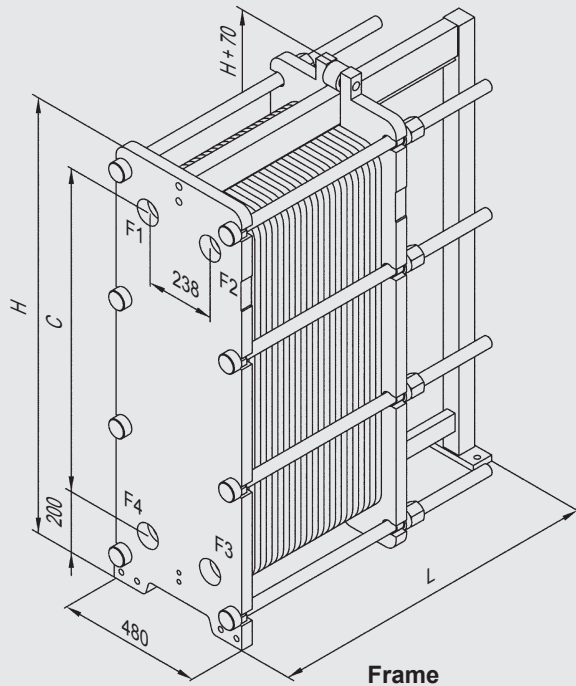

Pressure ranges: 10 bar, 16 bar

Size	Dimension H	Dimension C
H74	1,441 mm	1,070 mm
H102	1,855 mm	1,484 mm

H82 / H84 / H124 / H172 / H220

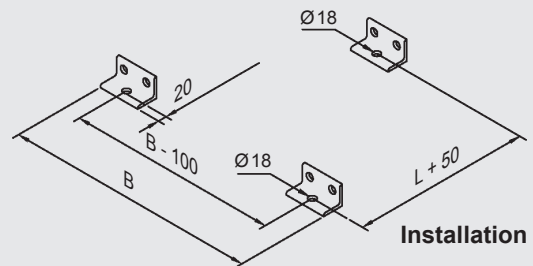
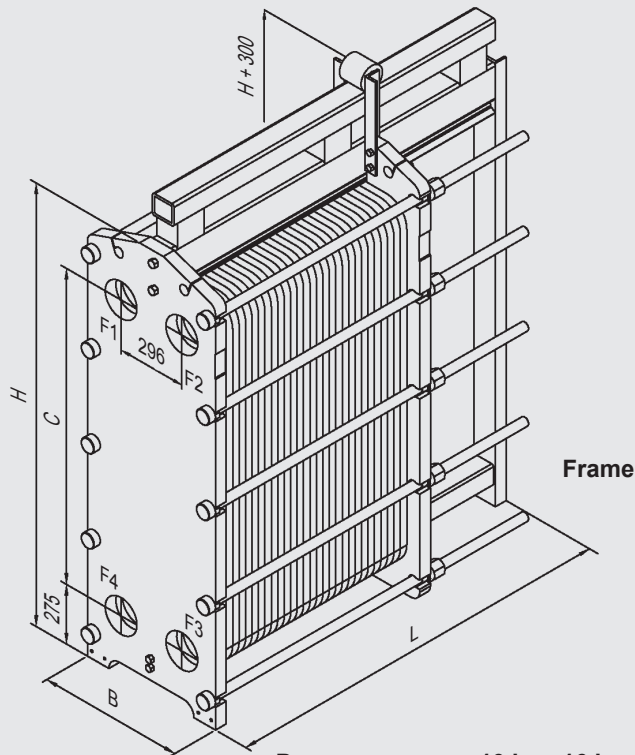

Pressure ranges: 10 bar, 16 bar, 25 bar

Size	Dimension H	Dimension C	Dimension B 10, 16 bar	Dimension B 25 bar
H82 / H84	1,450 mm	890 mm	608 mm	640 mm
H124	1,852 mm	1,292 mm	608 mm	640 mm
H172	2,254 mm	1,694 mm	608 mm	640 mm
H220	2,654 mm	2,094 mm	608 mm	640 mm

Note

The information in this brochure relates to the operating conditions and applications described.

For applications and operating conditions not described, please contact the relevant technical department.

Subject to technical modifications.



HYDAC COOLING GMBH

INTERNATIONAL

Industriegebiet
66280 Sulzbach/Saar
Germany

Tel.: +49 6897 509-01
Fax: +49 6897 509-454

E-mail: cooling@hydac.com
Internet: www.hydac.com

Feed Pumps FZP / MFZP

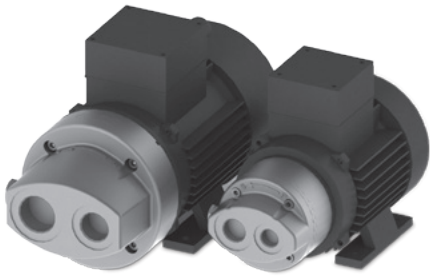

Symbol

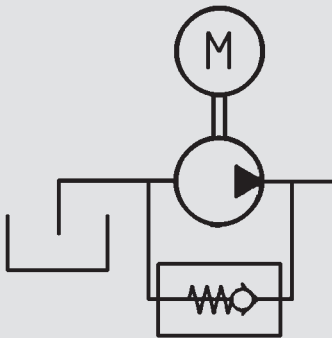

General

The feed pump from the FZP series is a vane pump for the low-pressure range with constant flow rate.

Product Features

- Direct drive pump – no bell housing or coupling required
- Standard with internal pressure limitation valve
- Optional with flange-mounted motor
- Small construction lengths

Application Field

- Filter circuits
- Cooling circuits
- Lubrication technology
- Pump transfer units

Operation Data

Operating pressure	max. 10 bar			
Pressure at the suction port	<ul style="list-style-type: none"> ● max. -0.4 bar suction underpressure ● max. 0.5 bar overpressure 			
Medium	Mineral oil to DIN 51524 Part 1 and Part 2			
Permissible contamination	≤ NAS 12			
Temperature of medium	-20 °C to +80 °C for mineral oil			
Viscosity	See characteristic curves			
Ambient temperature	-20 °C to +40 °C			
Mounting position	No restrictions			
RPM	<ul style="list-style-type: none"> ● min. 1,000 rpm ● max. 2,000 rpm Direction of rotation – right-turning (view of motor fan wheel)			
Drive (only MFZP)	Drive type: electric motor Current type: three-phase current For power and voltage see model code Protection class: IP 55 Insulation class: F			
Volumetric efficiency	>90% (at $v = 40 \text{ mm}^2/\text{s}$)			
Weights	FZP-1:		1.4 kg	
	FZP-2:		3.9 kg	
	FZP-3:		9.6 kg	
	MFZP-1/2.0	0.18 kW	6.0 kg	
	MFZP-1/2.0	0.37 kW	7.4 kg	
	MFZP-2/2.1	0.75 kW	13.5 kg	
	MFZP-2/2.1	1.50 kW	19.5 kg	
	MFZP-3/3.0	2.20 kW	32.5 kg	
	MFZP-3/3.0	4.00 kW	39.5 kg	
Noise levels		ccm/rev	1 bar	6 bar
	Size 1	3.5	58	62
		7.0	58	63
		10.0	60	64
	Size 2	20.0	66	68
		30.0	67	68
		40.0	69	70
	Size 3	70.0	69	71
		100.0	76	78
		130.0	77	78

Test fluid: ISO VG46 at 40 °C (40 mm²/s)
 The noise level values serve as guidelines,
 as room acoustics, connections, viscosity and reflection
 affect the level of noise.

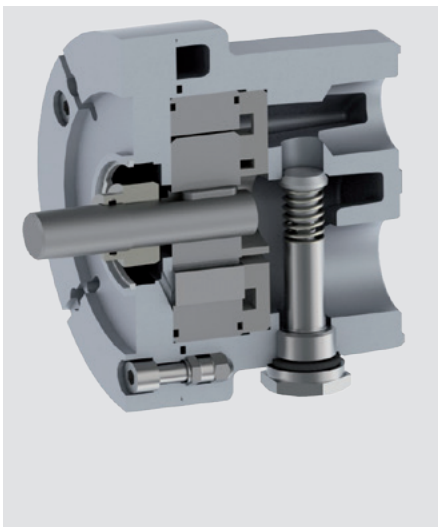
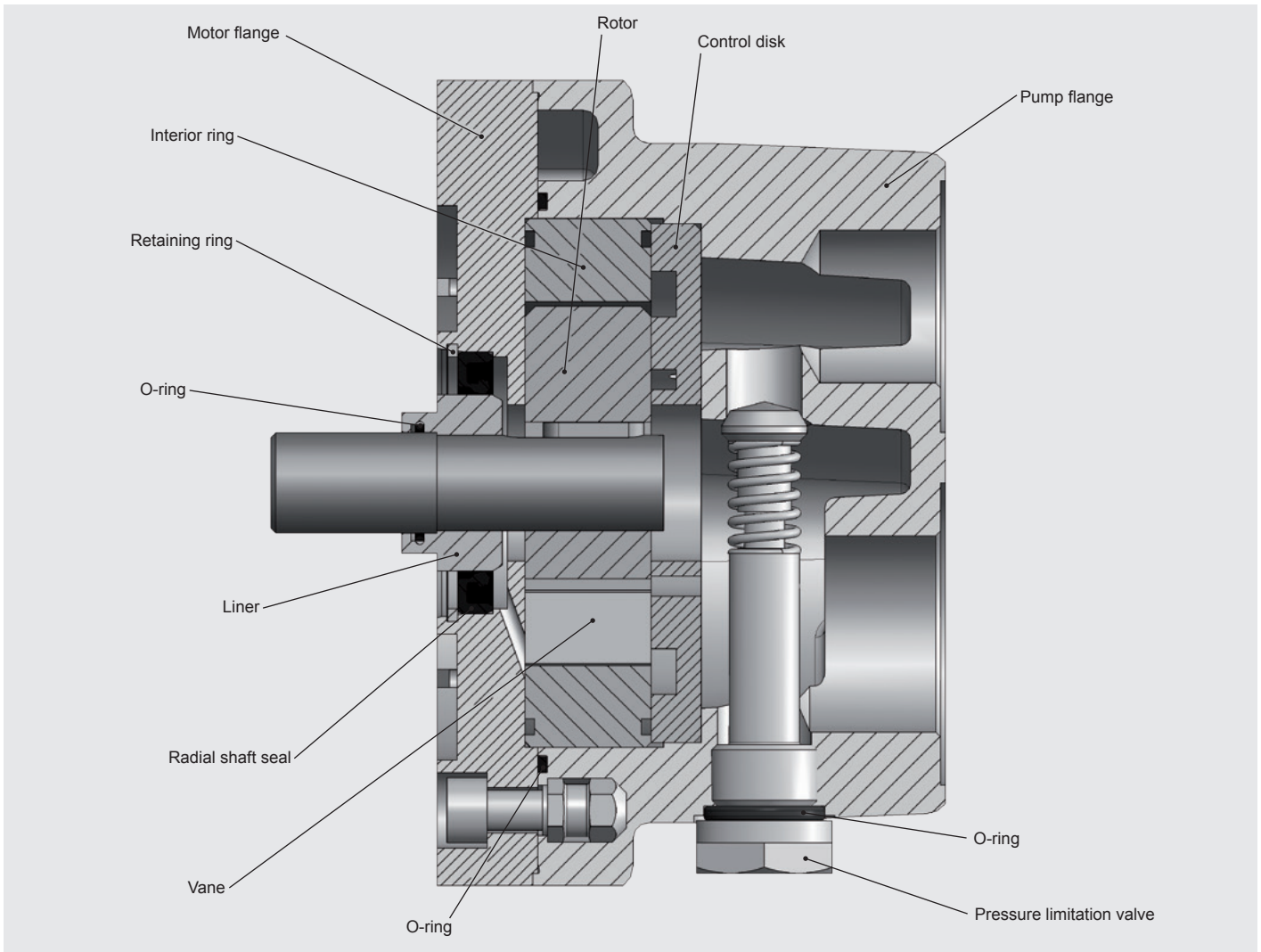

Note regarding tubing
pressure differences (flow loss)

- Simplified for hydraulic oils:

$$\Delta p \text{ [bar]} = 5.84 \cdot \frac{l \text{ [m]}}{d^4 \text{ [mm]}} \cdot Q \text{ [l/min]} \cdot \gamma \text{ [mm}^2\text{/s]}$$

- Influence of the interior diameter on flow losses with the following example values:
l = 1 m, Q = 150 l/min, $\gamma = 200 \text{ mm}^2\text{/s}$

	Internal diameter [mm]		
	di ₁ (38)	di ₁ (32)	di ₁ (25)
$\Delta p \text{ [bar]}$	0.084	0.167	0.45

- Observations apply only for straight pipes
- Additional threaded joints and pipe bends increase flow loss

Note:

- As few threaded connections as possible
- Few pipe bends – where bends are used, with large bending radius
- Difference in height between pump and oil level as small as possible
- Hoses must be suitable for a vacuum of min. 5,000 mmW (e.g. by means of steel wire insert)
- Do not reduce the pipe cross-section determined by the threaded connection

Control Curves

FZP-1

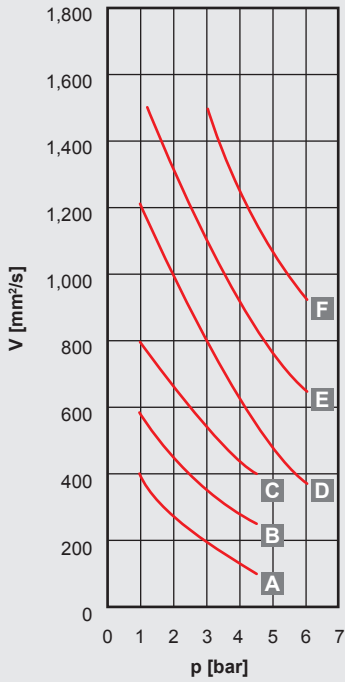

A	10.0 cm ³ / rev – 0.18 kW / 0.2 kW DC
B	7.0 cm ³ / rev – 0.18 kW / 0.2 kW DC
C	3.5 cm ³ / rev – 0.18 kW / 0.2 kW DC
D	10.0 cm ³ / rev – 0.37 kW
E	7.0 cm ³ / rev – 0.37 kW
F	3.5 cm ³ / rev – 0.37 kW

FZP-2

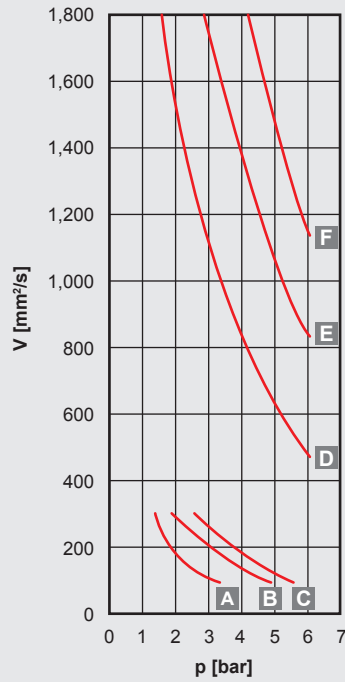

A	40 cm ³ / rev – 0.75 kW
B	30 cm ³ / rev – 0.75 kW
C	20 cm ³ / rev – 0.75 kW
D	40 cm ³ / rev – 1.5 kW
E	30 cm ³ / rev – 1.5 kW
F	20 cm ³ / rev – 1.5 kW

FZP-3

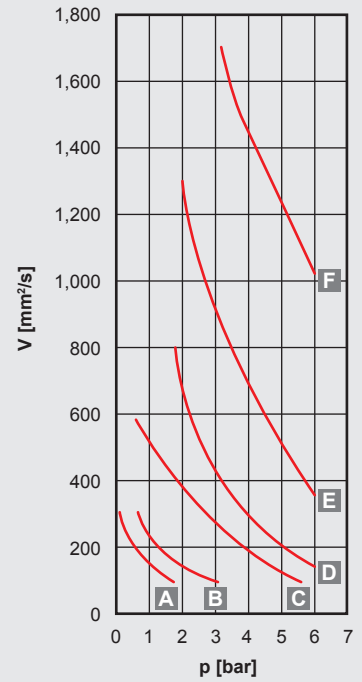

A	130 cm ³ / rev – 2.2 kW
B	100 cm ³ / rev – 2.2 kW
C	70 cm ³ / rev – 2.2 kW
D	130 cm ³ / rev – 4.0 kW
E	100 cm ³ / rev – 4.0 kW
F	70 cm ³ / rev – 4.0 kW

**Viscosity-temperature graph
to DIN 51519 viscosity index 50**

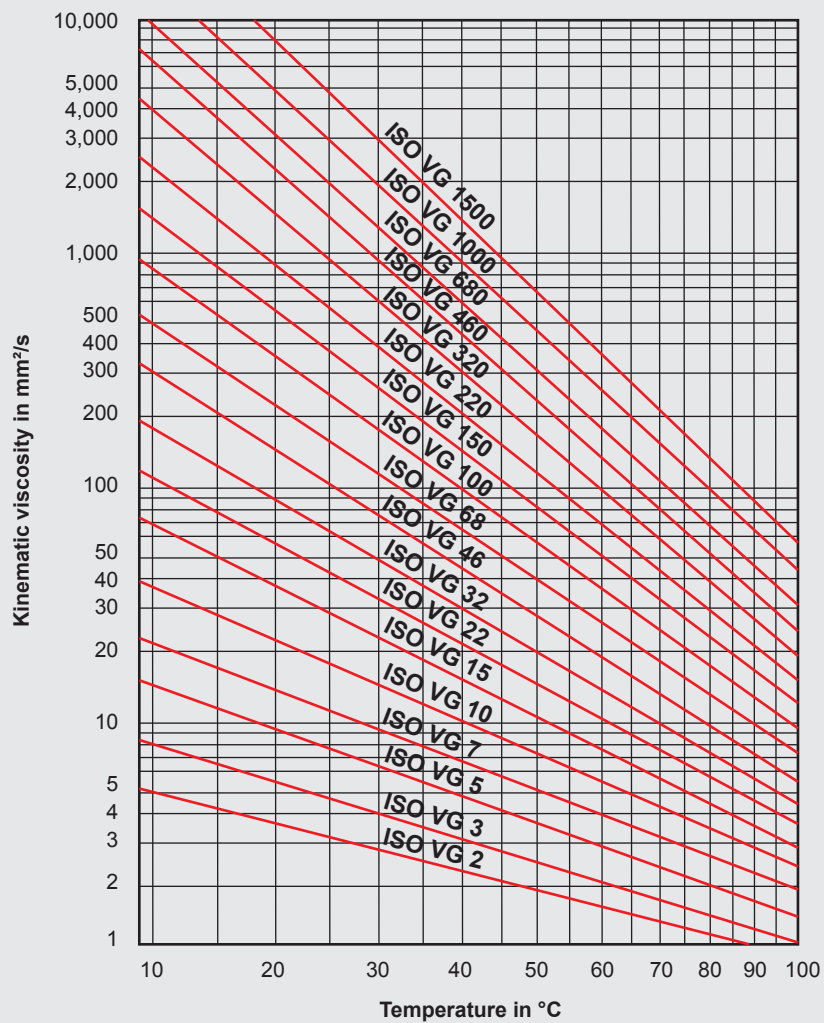

Design

Pump (FZP or MFZP) selected in accordance with customer specifications.

Example:

Flow rate: 190 l/min
 Counter-pressure: 5 bar
 Viscosity: 200 cSt
 Motor voltage: 400 V – 50 Hz

Selection:

190 l/min → FZP-3 / MFZP-3 (approx. 130 ccm/rev at 1,500 rpm)
 5 bar and 200 cSt → drive power 4 kW (= motor size 112)

Result:

FZP-3/3.0/P/100/130/RV6
 MFZP-3/3.0/P/112/130/RV6/4/400-50

Dimensions

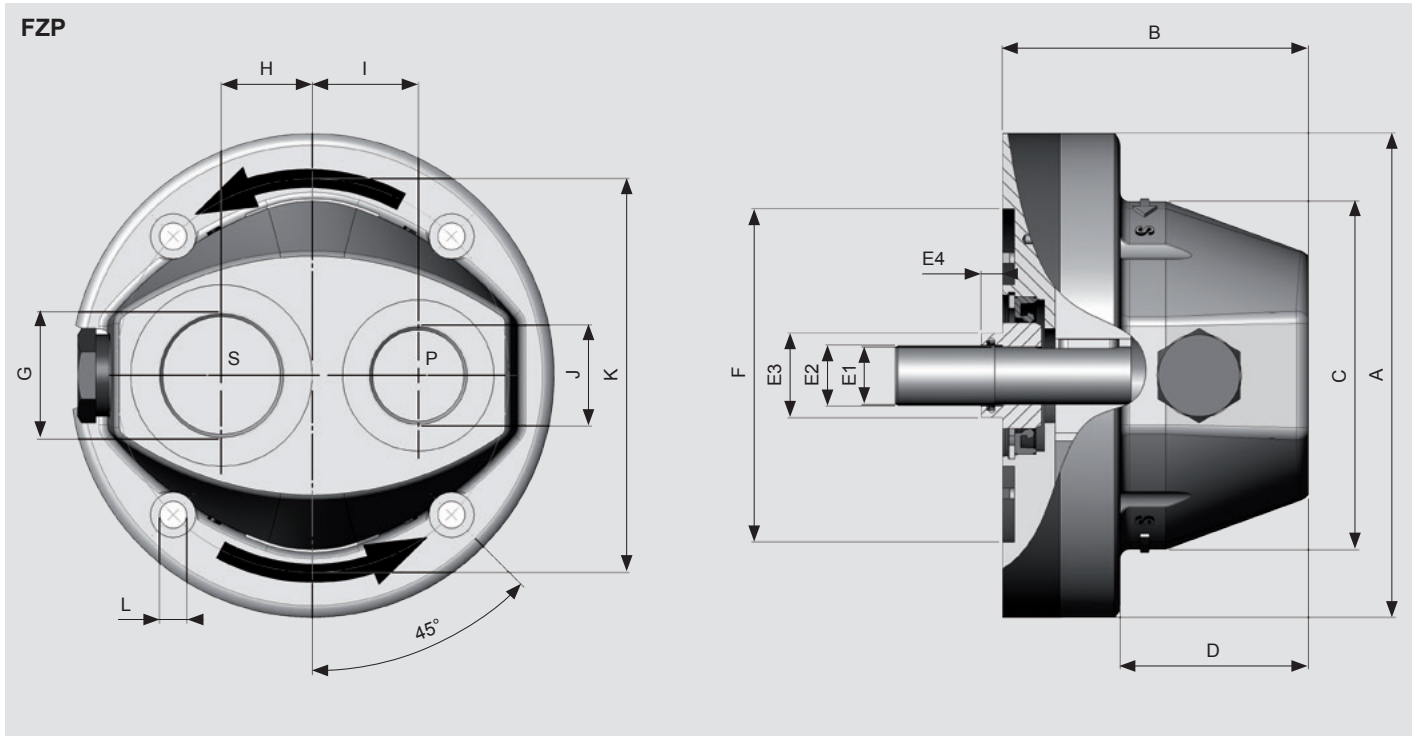

[mm]

Assembly	Flow capacity l/min at n = 1,500 rpm	Pump dimensions														
		A	B	C	D	E1	E2	E3	E4	F	G	H	I	J	K	L
1	5 – 15	105	75	70	26	14	17	24	5	70	G ¾	20.00	20.00	G ½	85	7
2	30 – 60	160	100	100	33	19	20	35	7	110	G 1 ¼	30.00	35.00	G 1	130	9
						24	25	35	7							
3	100 – 200	200	130	140	35	28	30	40	7	130	G 2	43.75	43.75	G 1 ½	165	11

Dimensions

MFZP

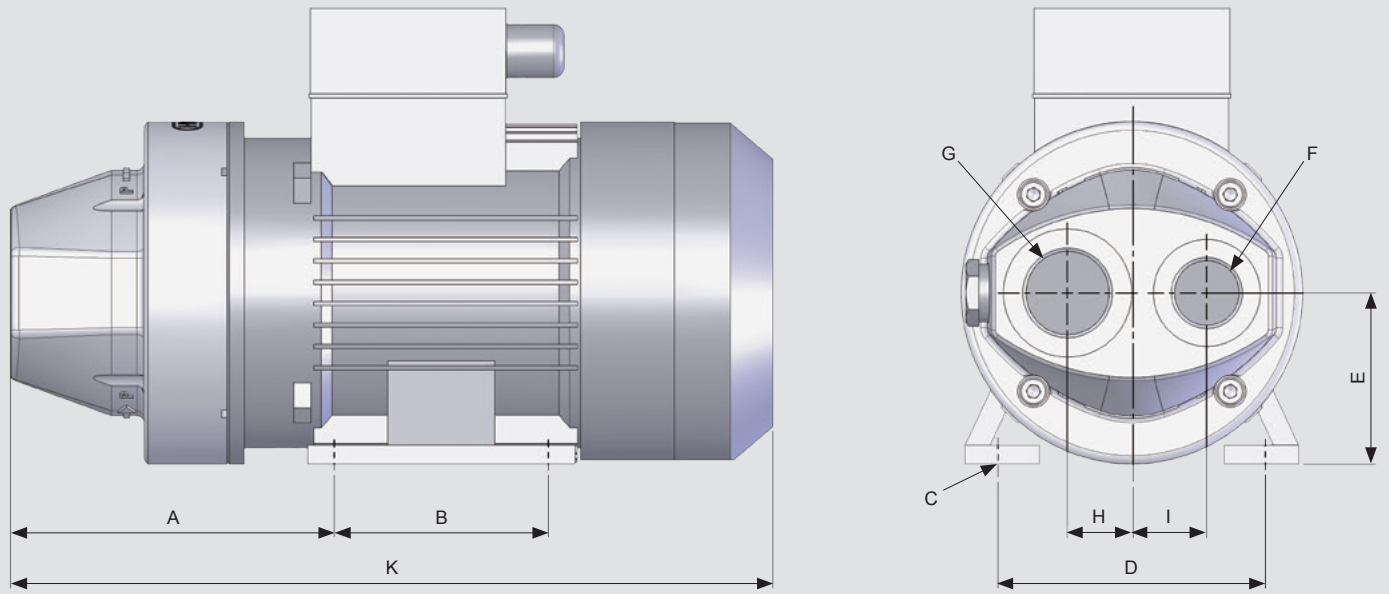

[mm]

	A	B	C	D	E	F	G	H	I
MFZP-1/2.0/X/63	89	80	7	100	63	G ½	G ¾	20.00	20.00
MFZP-1/1.1/X/AMG	117	80	7	100	63	G ½	G ¾	20.00	20.00
MFZP-1/1.1/X/71	120	90	7	112	71	G ½	G ¾	20.00	20.00
MFZP-2/2.1/X/80	150	100	9	125	80	G 1	G 1¼	30.00	35.00
MFZP-2/2.1/X/90	156	125	9	140	90	G 1	G 1¼	30.00	35.00
MFZP-3/3.0/X/100	193	140	12	160	100	G 1½	G 2	43.75	43.75

Construction length "K" of motor pump groups:

	El. motor size	Flange	Length "K" [mm]
MFZP-1	63/0.18 kW	Spec. flange	approx. 260
MFZP-1	AMG/0.2 kW/B34	Small flange	approx. 245
MFZP-1	71/0.37 kW/B34	Small flange	approx. 320
MFZP-2	80/0.75 kW/B34	Large flange	approx. 340
MFZP-2	90/1.2 kW/B34	Large flange	approx. 380
MFZP-3	100/2.2 kW/B34	Large flange	approx. 450
MFZP-3	100/4 kW/B34	Large flange	approx. 480

Model Type

MFZP-2 - 2.1 - P - 90/40 - RV6 - 1.5/400-50

Motor pump group MFZP _____

(with motor)

Direct drive pump FZP _____

Assembly _____

1

2

3

Modification number _____

(see flow rate table)

Seals _____

P = Perbunan

V = Viton

(other seals on request)

Motor size and flow rate _____

Assembly	Motor size	Modification number	Flow rate in ccm/revolutions (other rates on request)								
			3.5	7	10	20	30	40	70	100	130
1	63 (0.18 kW, only MFZP)	2.0	•	•	•						
	AMG (0.2 kW, DC)	1.1	•	•	•						
	71 (0.37 kW)	1.1	•	•	•						
2	80 (0.75 kW)	2.1				•	•	•			
	90 (1.5 kW)	2.1				•	•	•			
3	100 (2.2 kW)	3.0							•	•	•
	112 (4.0 kW)	3.0							•	•	•

Pressure relief valve _____

RV3 (3.0 bar)

RV4.5 (4.5 bar)

RV6 (6.0 bar) (preferred size)

RV10 (10.0 bar)

Motor power and voltage _____

n = 1,500 rpm

(other voltages and frequencies on request)

Size 1:

0.18 kW

0.37 kW

Size 2:

0.75 kW

1.50 kW

Size 3:

2.20 kW

4.00 kW

Standard voltages and frequencies in three-phase motors

400 V star / 230 V delta – 50 Hz

(other voltages and frequencies on request)

Design Data Sheet, Feed Pumps

Project: _____
Contact: _____
Telephone: _____
E-mail: _____

Medium: _____ (Enclose data sheet for the medium)

Fluid temperature: _____ °C

Fluid purity: _____

Spec. materials prescribed? _____

Seal material: Perbunan (NBR) Viton (FPM)
 Other: _____

Flow rate: _____ l/min

Suction height: _____ m

Operating pressure: _____ bar

Max. pressure: _____ bar (pressure limitation valve)

Electrical data

Motor rating: _____ kW

Voltage: _____ V _____ Hz

Speed: _____ rpm

Direction of rotation: _____

Installation position
of the pump: _____

Installation space limited? _____

Permitted noise level: _____ dB(A)

Ambient temperature: _____ °C

Unit qty. per year: _____

Remarks/miscellaneous:

Note

The information in this brochure relates to the operating conditions and applications described.

For applications and operating conditions not described, please contact the relevant technical department.

Subject to technical modifications and corrections.



HYDAC COOLING GMBH

INTERNATIONAL

Industriegebiet
66280 Sulzbach/Saar
Germany

Tel.: +49 6897 509-01
Fax: +49 6897 509-454

E-mail: cooling@hydac.com
Internet: www.hydac.com

HYDAC AG
Mezzovico
branch office

Via Sceresca, Zona Industriale 3
6805 Mezzovico
Switzerland

Tel.: +41 91 9355-700
Fax: +41 91 9355-701

E-mail: info@hydac.ch
Internet: www.hydac.com

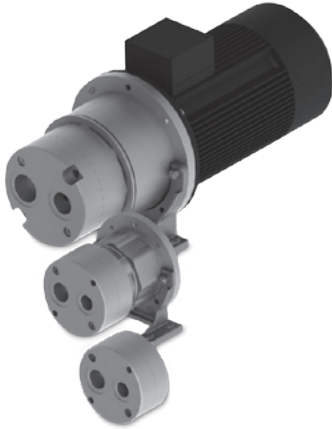

Feed Pumps VP / VPB / VPBM

Symbol

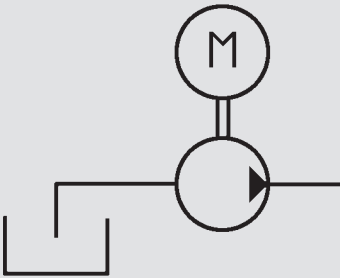

General

The feed pumps from the VP series are low-noise, single-stroke vane pumps with constant flow rate.

Using a damped bell housing (PT) enables noise levels to be reduced.

Product Features

- Pump with bell housing and coupling
- Optional with flange-mounted motor
- Low-noise version

Application Field

- Filter circuits
- Cooling circuits
- Lubrication technology
- Pump transfer units

Operation Data

Operating pressure	max. 16 bar				
Pressure at the suction port	max. -0.4 bar for mineral oil				
Medium	Mineral oil to DIN 51524 Part 1 and Part 2				
Permissible contamination	≤ NAS 12				
Temperature of medium	-20 °C to +80 °C for mineral oil				
Viscosity	See characteristic curves				
Ambient temperature	-20 °C to +40 °C				
Mounting position	Ideally horizontal				
RPM	<ul style="list-style-type: none"> ● min. 1,000 rpm ● max. 2,000 rpm Direction of rotation – right-turning (view of motor fan)				
Drive (only VPBM)	Drive type: electric motor Current type: three-phase current Power and voltage: see model code Protection type: IP 55 Insulation class: F				
Volumetric efficiency	>90% (at $v = 40 \text{ mm}^2/\text{s}$)				
Weights	VP-2		5.0 kg		
	VP-3		13.0 kg		
	VPB-2		8.5 kg		
	VPB-3	2.20 - 4.0 kW	18.0 kg		
	VPB-3	5.50 - 7.5 kW	19.5 kg		
	VPBM-2	0.75 kW	18.0 kg		
	VPBM-2	1.50 kW	24.0 kg		
	VPBM-3	2.20 kW	39.0 kg		
	VPBM-3	4.00 kW	49.0 kg		
	VPBM-3	5.50 kW	60.0 kg		
VPBM-3	7.50 kW	79.0 kg			
Noise levels in dB(A)		ccm/rev	1 bar	6 bar	10 bar
	Size 2	20	57	60	63
		30	60	61	64
		40	61	62	64
	Size 3	70	62	64	67
		100	66	67	69
		130	68	69	70

Test fluid: ISO VG46 at +40 °C (40 mm²/s)
 Measurements with damped pump mount
 The noise level values serve as guidelines, as room acoustics, connections, viscosity and reflection affect the level of noise.

The low-noise pumps from the VP series can be combined with various hydraulic pumps. For specific details, contact the specialist department.

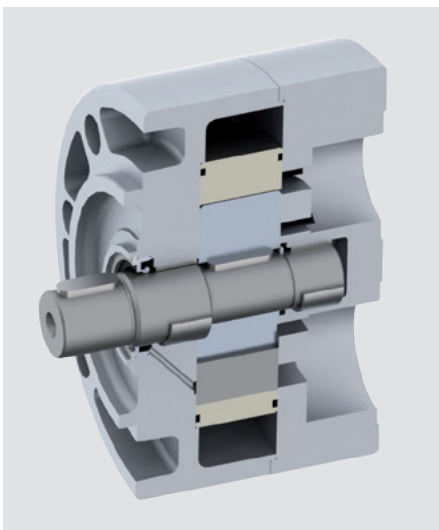
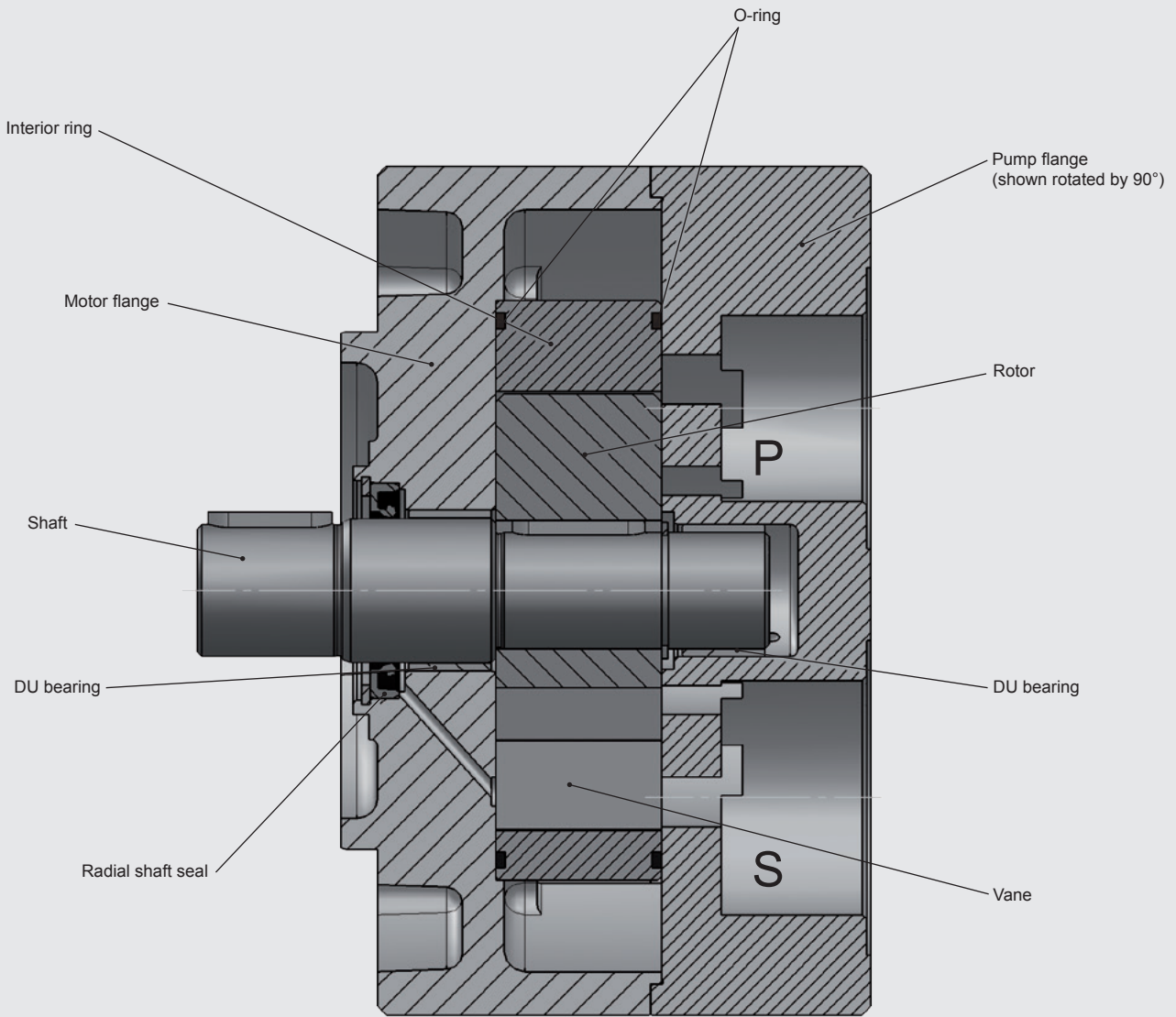

Note regarding tubing
pressure differences (flow loss)

$$\Delta p \text{ [bar]} = 5.84 \cdot \frac{l \text{ [m]}}{d^4 \text{ [mm]}} \cdot Q \text{ [l/min]} \cdot \gamma \text{ [mm}^2\text{/s]}$$

- Influence of the interior diameter on flow losses with the following example values:
l = 1 m, Q = 150 l/min, $\gamma = 200 \text{ mm}^2\text{/s}$

	Internal diameter [mm]		
	di ₁ (38)	di ₁ (32)	di ₁ (25)
$\Delta p \text{ [bar]}$	0.084	0.167	0.45

- Observations apply only for straight pipes
- Additional threaded joints and pipe bends increase flow loss.

Note:

- As few threaded connections as possible
- Few pipe bends – where bends are used, with large bending radius
- Difference in height between pump and oil level as small as possible
- Hoses must be suitable for a vacuum of min. 5,000 mmW (e.g. by means of steel wire insert)
- Do not reduce the pipe cross-section determined by the threaded connection.

Control Curves

VP-2

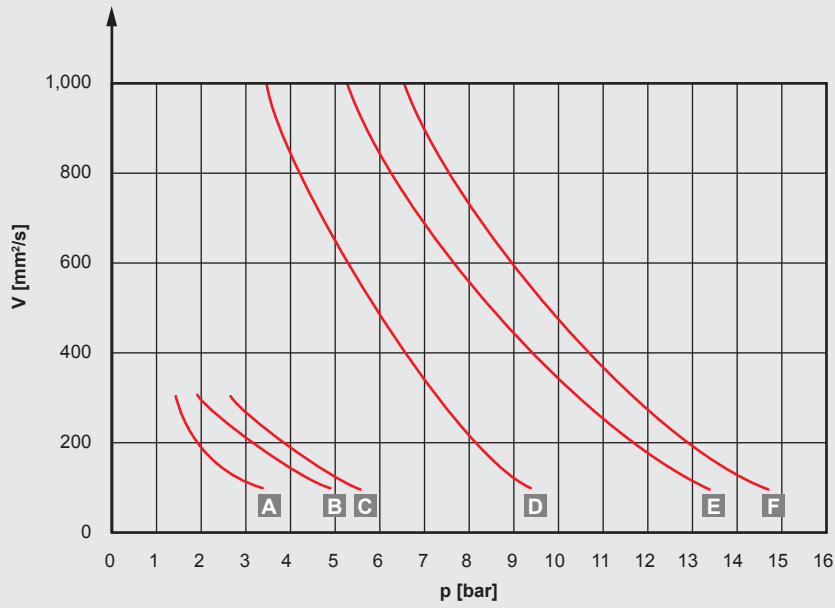

- A** 40 cm^3 / rev – 0.75 kW
- B** 30 cm^3 / rev – 0.75 kW
- C** 20 cm^3 / rev – 0.75 kW
- D** 40 cm^3 / rev – 1.50 kW
- E** 30 cm^3 / rev – 1.50 kW
- F** 20 cm^3 / rev – 1.50 kW

VP-3

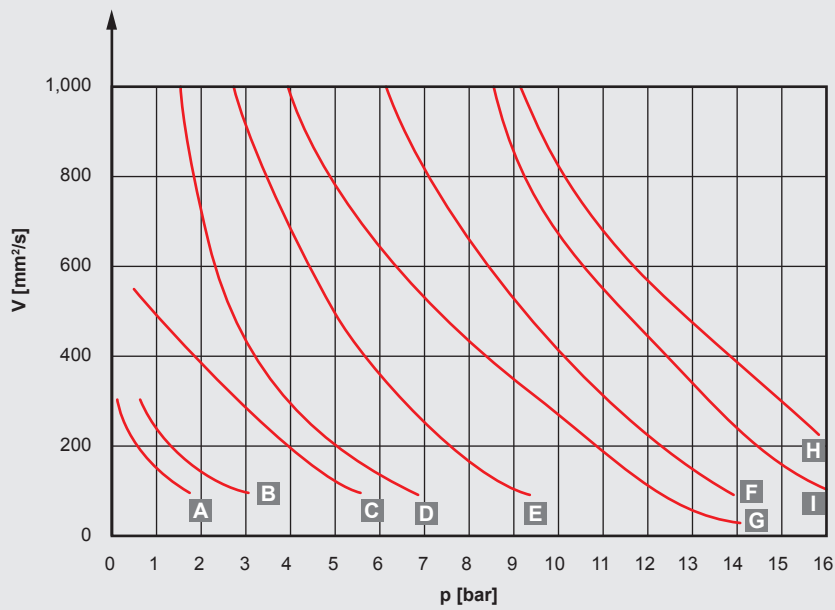

- A** 130 cm^3 / rev – 2.2 kW
- B** 130 cm^3 / rev – 2.2 kW
- C** 70 cm^3 / rev – 2.2 kW
- D** 130 cm^3 / rev – 4.0 kW
- E** 100 cm^3 / rev – 4.0 kW
- F** 70 cm^3 / rev – 4.0 kW
- G** 130 cm^3 / rev – 5.5 kW
- H** 130 cm^3 / rev – 7.5 kW
- I** 100 cm^3 / rev – 5.5 kW

**Viscosity-temperature graph
to DIN 51519 viscosity index 50**

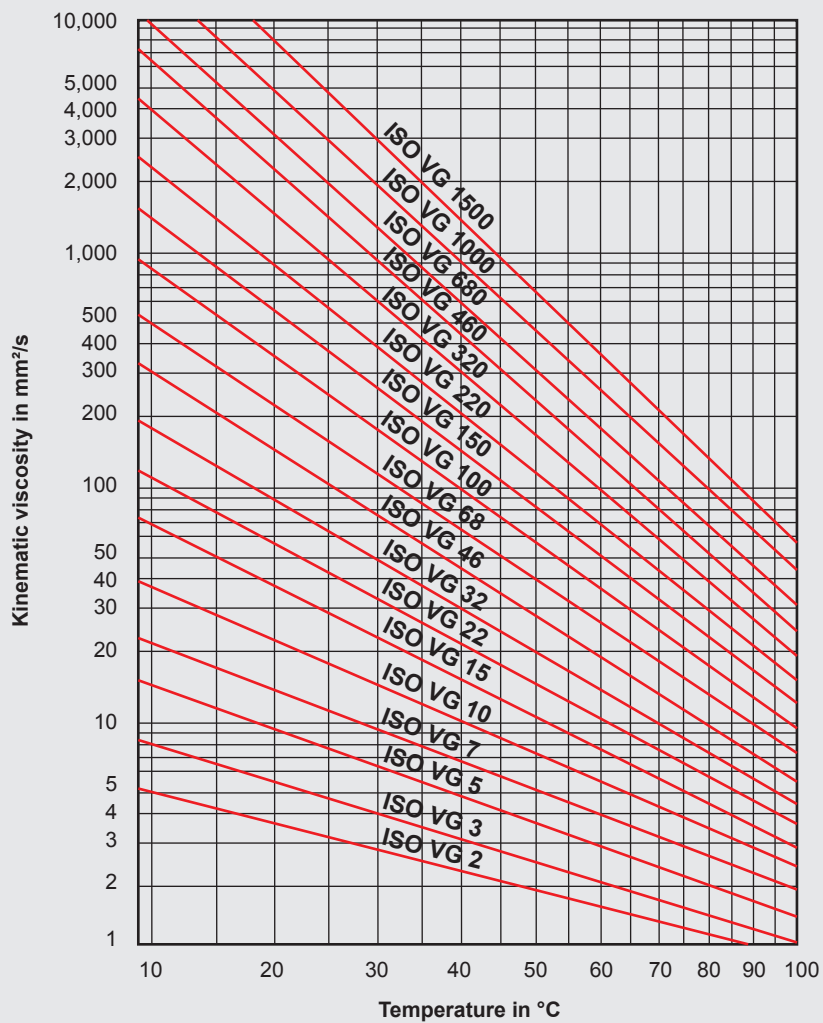

Design

Pump (VP, VPB or VPBM) selected in accordance with customer specifications.

Example:

Flow rate: 190 l/min
 Counter-pressure: 5 bar
 Viscosity: 200 cSt
 Motor voltage: 400 V – 50 Hz

Selection:

190 l/min → VP-3 / VPBM-3 (approx. 130 ccm/rev at 1,500 rpm)
 5 bar and 200 cSt → drive power 4 kW (= motor size 112)

Result:

VP-3/1.0/P/-/130
 VPBM-3/1.0/P/112/130/4/400-50

Dimensions

VP

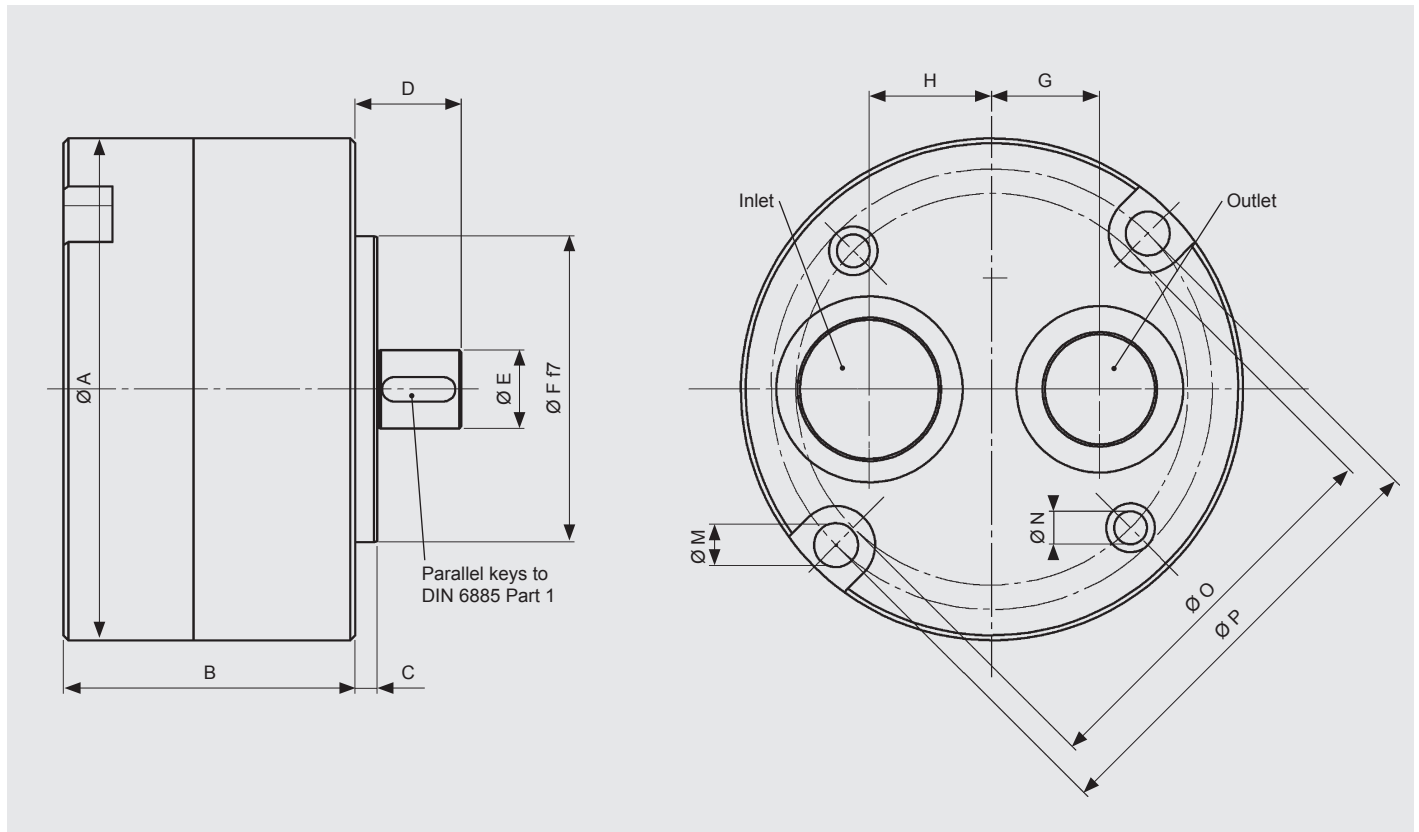

Assembly	Flow rate l/min 1,500 rpm	A	B	C	D	E	F	G	H	M	N	O	P
VP-2	30 – 60	160	79.5	7	44	22	100	30	35	13.5	11.0	125	140
VP-3	100 – 200	205	119.0	7	44	32	125	44	50	17.0	13.5	160	180

Ports

VP-2

Inlet: G 1¼"
Outlet: G 1"

VP-3

Inlet: G 2"
Outlet: G 1½"

Dimensions

VPB

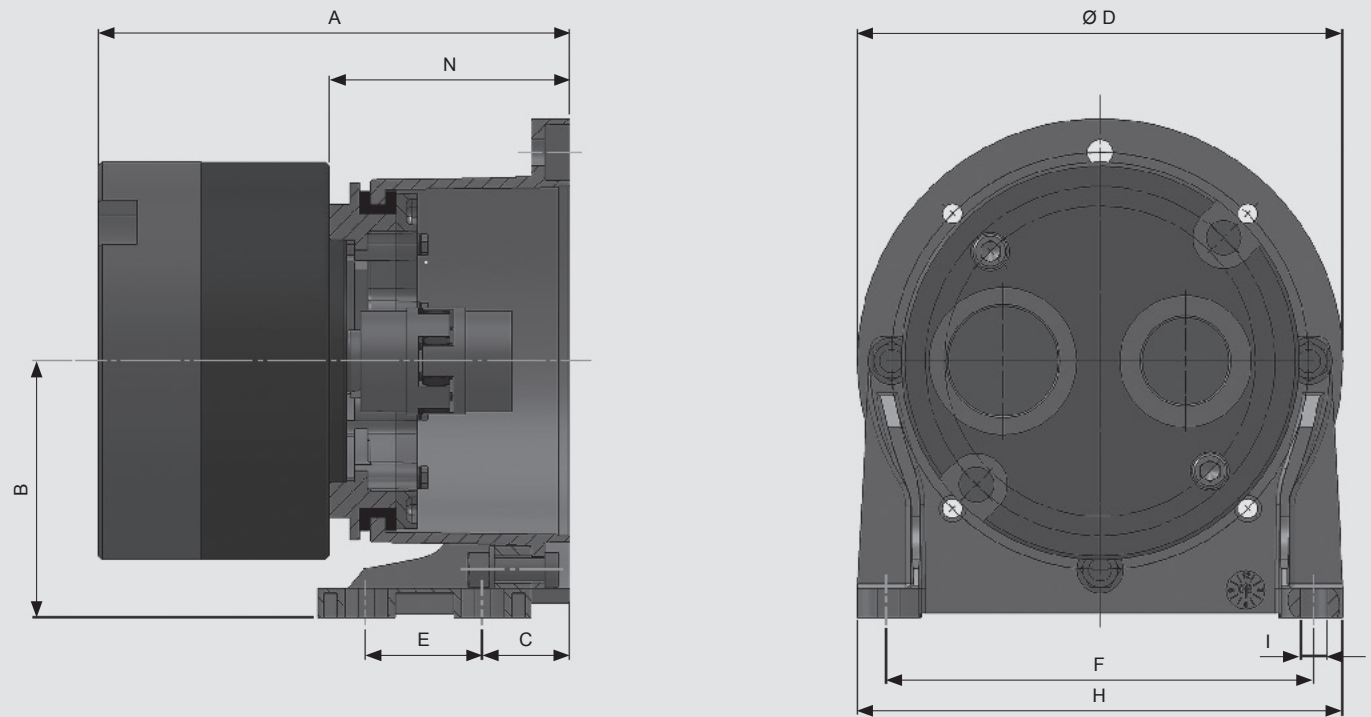

VPBM

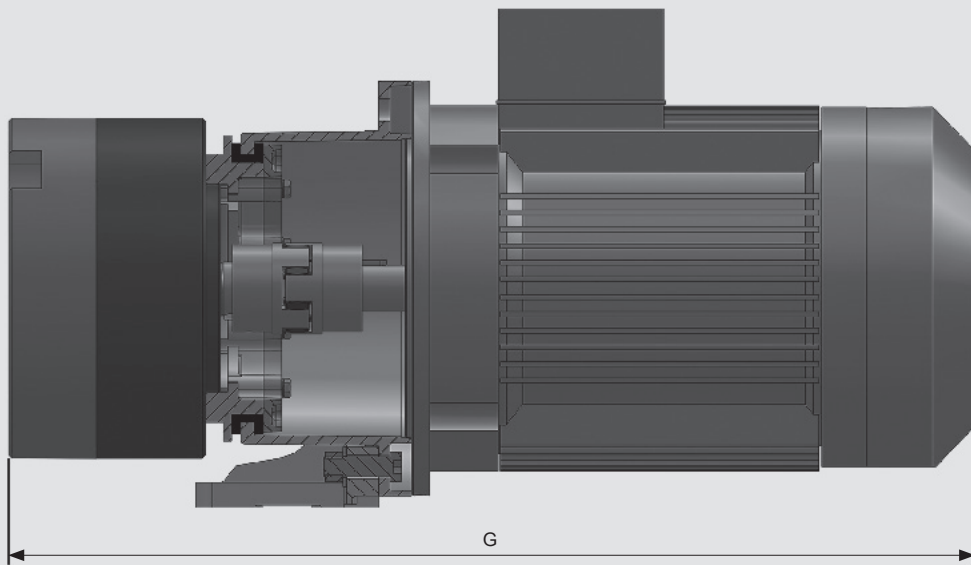

Size	Motor size		A	B	C	D	E	F	G	H	I	N
2	80	0.75 kW	192.5	112	19	200	60	180	480	210	11	113
	90	1.50 kW	192.5	112	19	200	60	180	485	210	11	113
3	100	2.20 kW	243.0	132	40	250	60	220	560	250	14	124
	112	4.00 kW	243.0	132	40	250	60	220	580	250	14	124
	132	5.50 kW	263.0	160	39	300	80	260	680	290	14	144
	132	7.50 kW	263.0	160	39	300	80	260	680	290	14	144

Model Type

VPBM-2 - 1.0 - P - 90/40 - 1.5/400-50

Pump

VP = pump

VPB = pump + PT + coupling

VPBM = pump + PT + coupling + motor

(PT = bell housing)

Assembly

2

3

Modification number

Seals

P = Perbunan

V = Viton

(other seals on request)

Motor size and flow rate

Assembly	Motor size	Motor rating	Flow rate in ccm/revolutions (other rates on request)					
			20	30	40	70	100	130
2	80	0.75 kW	•	•	•			
	90	1.50 kW	•	•	•			
3	100	2.20 kW				•	•	•
	112	4.00 kW				•	•	•
	132	5.50 kW					•	•
	132	7.50 kW						•

(Caution: maximum pressure 16 bar)

Motor power and voltage

(only VPBM)

n = 1,500 rpm

Motor version:

B5

Size 2: motor power

0.75 kW

1.50 kW

Size 3: motor power

2.2 kW

4.0 kW

5.5 kW

7.5 kW

Standard voltages and frequencies for three-phase motors

Motor power 0.75 kW – 4 kW

400 V star / 230 V delta – 50 Hz

Motor power 5.5 kW – 7.5 kW

690 V star / 400 V delta – 50 Hz

Other voltages and frequencies on request.

Design Data Sheet, Feed Pumps

Project: _____
Contact: _____
Telephone: _____
E-mail: _____

Medium: _____ (Enclose data sheet for the medium)

Fluid temperature: _____ °C

Fluid purity: _____

Spec. materials prescribed? _____

Seal material: Perbunan (NBR) Viton (FPM)
 Other: _____

Flow rate: _____ l/min

Suction height: _____ m

Operating pressure: _____ bar

Max. pressure: _____ bar (pressure limitation valve)

Electrical data

Motor rating: _____ kW

Voltage: _____ V _____ Hz

Speed: _____ rpm

Direction of rotation: _____

Installation position of the pump: _____

Installation space limited? _____

Permitted noise level: _____ dB(A)

Ambient temperature: _____ °C

Unit qty. per year: _____

Remarks / miscellaneous:

Note

The information in this brochure relates to the operating conditions and applications described.

For applications and operating conditions not described, please contact the relevant technical department.

Subject to technical modifications and corrections.



HYDAC COOLING GMBH

INTERNATIONAL

Industriegebiet
66280 Sulzbach/Saar
Germany

Tel.: +49 6897 509-01
Fax: +49 6897 509-454

E-mail: cooling@hydac.com
Internet: www.hydac.com

HYDAC AG
Mezzovico
branch office

Via Sceresca, Zona Industriale 3
6805 Mezzovico
Switzerland

Tel.: +41 91 9355-700
Fax: +41 91 9355-701

E-mail: info@hydac.ch
Internet: www.hydac.com



Pump-Transfer Cooler Filtration Unit UF 2-3 / UKF 1-3

Symbol

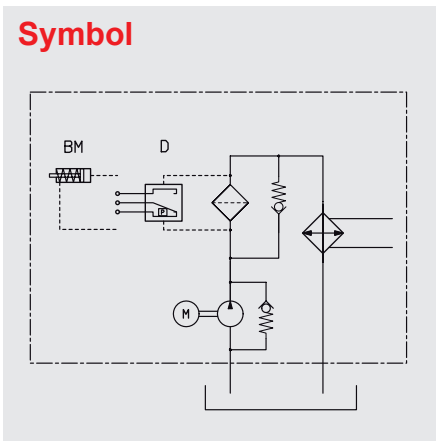

General

The UKF unit is a compact, easy-to-install system for offline filtration cooling circuits. It consists of a low-noise feed pump, a filter and a plate heat exchanger.

Product Features

Continuous cooling and offline filtration extend the service life of the oil and of the hydraulic system. The offline unit ensures constant oil temperature – regardless of the cycle times of the hydraulic systems. Furthermore, consistent flow rates prevent pressure spikes in the heat exchanger.

Application Field

- Plastic injection moulding machines
- Pressing / Stamping
- Machining centres
- Hydraulic systems
- Gears

Operating Data

General			
Ambient temperature	+10 °C to +40 °C		
Volumetric efficiency	>90 % at v = 40 mm ² /s		
Mounting position	UKF-1: Optional, but easier to maintain if filter below pump UKF-2 / UKF-3: vertical		
Noise levels	UKF-1: <64 dB(A) at 1,500 1/min		
	UKF-2 / UKF-3:		
	Pump [cm ³ /rev]	1 bar	6 bar
	15	61	61
	20	61	61
	30	61	62
	40	62	63
	50	64	66
	70	67	68
	100	68	70
	130	70	72

(Test medium: ISO VG46 at +40 °C)

The noise levels are only a guide as the acoustic properties of a room, connections, viscosity and reflections have an effect on the noise level.

Pump	
Suction pressure across the suction connection	max. -0.4 bar to 0.5 bar
Operating pressure (oil side)	max. 6 bar
Medium (oil side)	Mineral oil to DIN 51524 Part 1 and Part 2
Temperature range (oil side)	+10 °C to +80 °C
Permissible contamination (oil side)	≤NAS12 or ISO4406: 22/21/18
Max. viscosity	see viscosity-temperature graph
Drive	
Motor	Three-phase electric motor Insulation class: F Protection class: IP55
Speed	1,500 / 1,800 1/min (50/60 Hz)

Heat exchanger	
Heat exchanger connections:	Female thread (max. tightening torque 160 Nm) The pipes must be connected so that the connections are stress-free. Linear expansion and vibrations from the pipes to the heat exchanger must be avoided.
Medium (water side):	<ul style="list-style-type: none"> ● Water glycol (HFC) ● Water ● Oils
Temperature range (water side)	+5 °C to +60 °C
Operating pressure (water side):	max. 30 bar
Permissible contamination (water side)	The level of particles in suspension should be less than 10 mg/l. Particle size <0.6 mm (spherical) Thread-like particles cause a rapid increase in pressure losses.
Water quality	The following ions are not corrosive under normal conditions: phosphate, nitrate, nitrite, manganese, sodium and potassium also see table on water quality

Design

There are different versions possible depending on the requirements:

- UF** – Feed pump with filter
- UK** – Feed pump with plate heat exchanger
- UKF** – Feed pump with filter and plate heat exchanger

Offline unit consisting of:

- Low-noise feed pump
- Filter
- Oil-water plate heat exchanger
- The circuit is fitted with check valves to isolate the filter when used with a positive head tank when changing the filter element

UKF-1

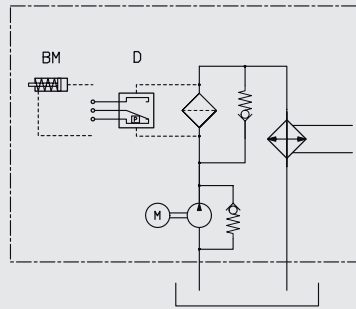

Flow rate:	5 – 15 l/min
Motor rating:	0.37 – 0.55 kW
Cooling capacity*:	up to 10 kW

UKF-2

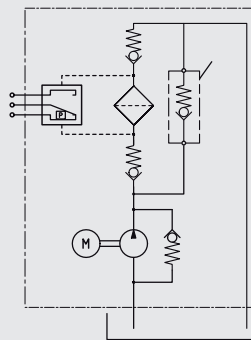

UF (without heat exchanger)

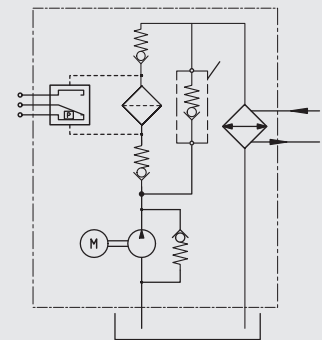

UKF

Flow rate:	15 – 60 l/min
Motor rating:	0.75 – 1.5 kW
Cooling capacity*:	up to 30 kW

UKF-3

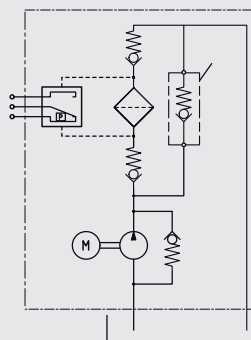

UF (without heat exchanger)

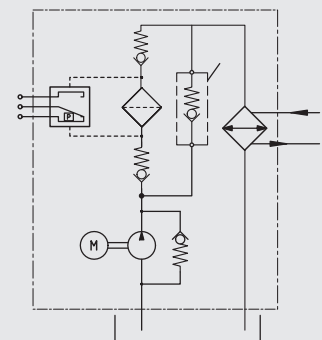

UKF

Flow rate:	20 – 200 l/min
Motor rating:	1.5 – 4 kW
Cooling capacity*:	up to 90 kW

* Dependent on temperature difference and flow rate of the cold and warm medium (see also "Pump-Transfer Cooler Filtration Unit Selection").

Water Quality

The following maximum limits are based on a water temperature of +60 °C.

Substances dissolved in water	Concentration (ppm)
pH value	7.0 – 9.0
Electrical conductivity	10 – 500 [μ S/cm]
Cl ⁻ (max. 60 °C)	<300
SO ₄ ⁻²	<50
CaCO ₃	<50
Fe	<0.3
NH ₃	<2
NO ₃	<100
S ⁻²	not suitable
SiO ₂	<30
NH ₄ ⁺	<0.1
Free chlorine	<0.1
CO ₃ ⁻²	<0.4
H ₂ S	<0.05

UKF-1

Clearance for filter element removal approx. 50 mm

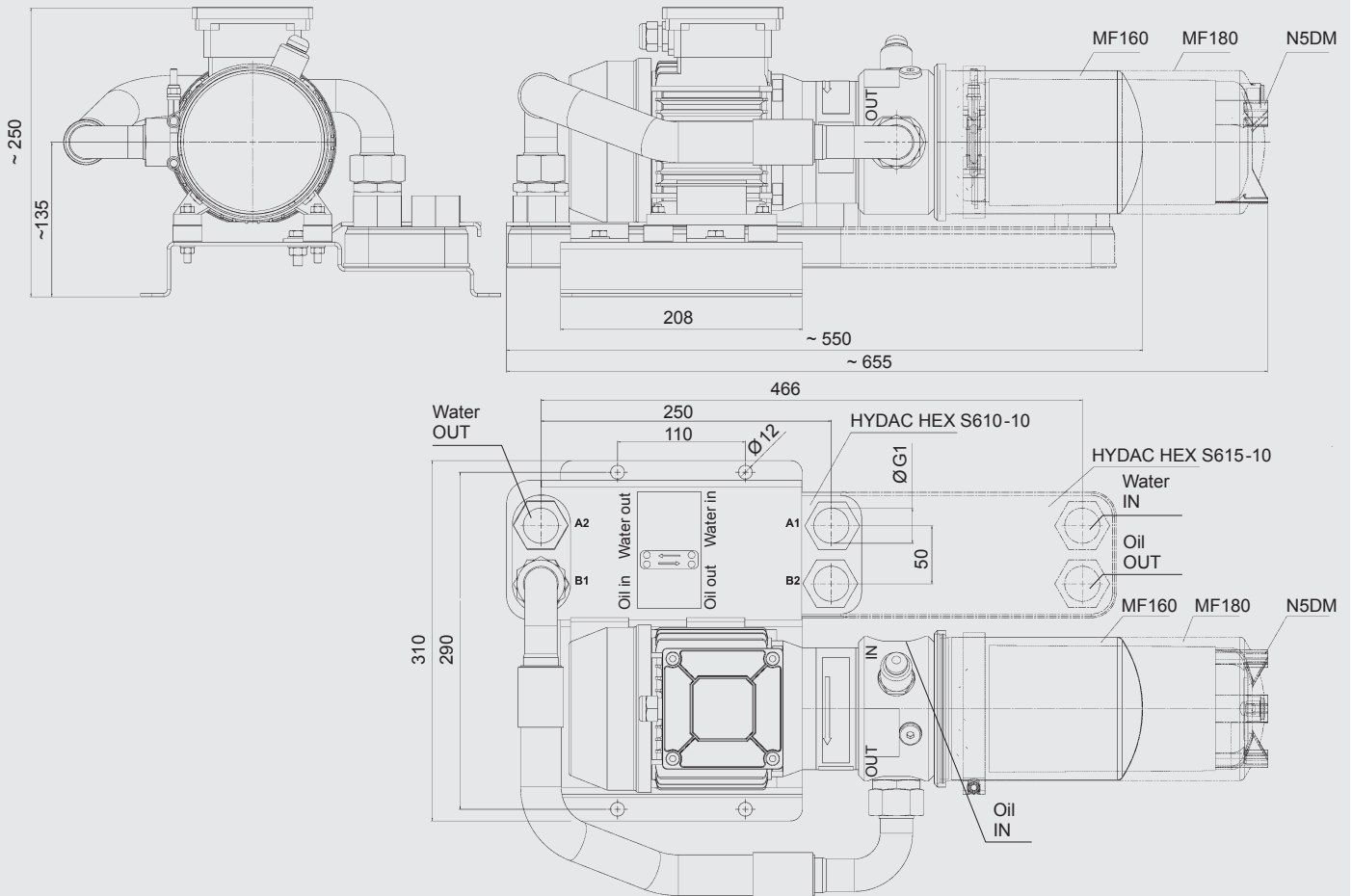

Weight (unfilled)

Basic unit (motor-pump unit + filter) + heat exchanger

Motor-pump unit	Heat exchanger
Basic unit: 12 kg	610-10: 3 kg
	610-20: 5 kg
	615-10: 6 kg
	615-20: 8 kg

UKF-2

UF-2

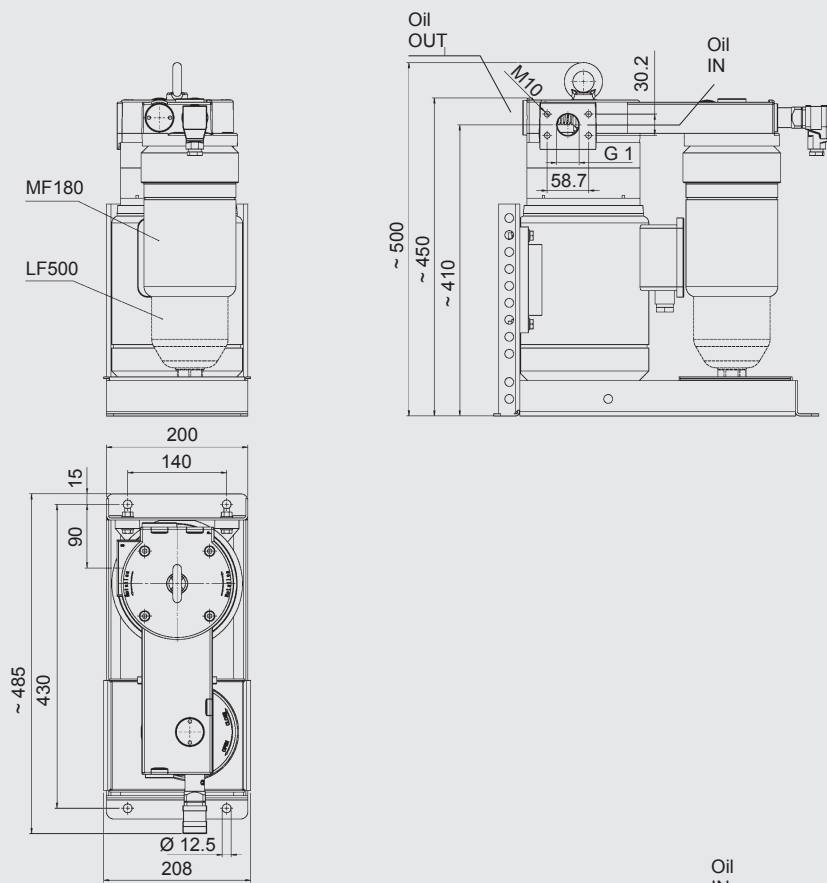

UKF-2

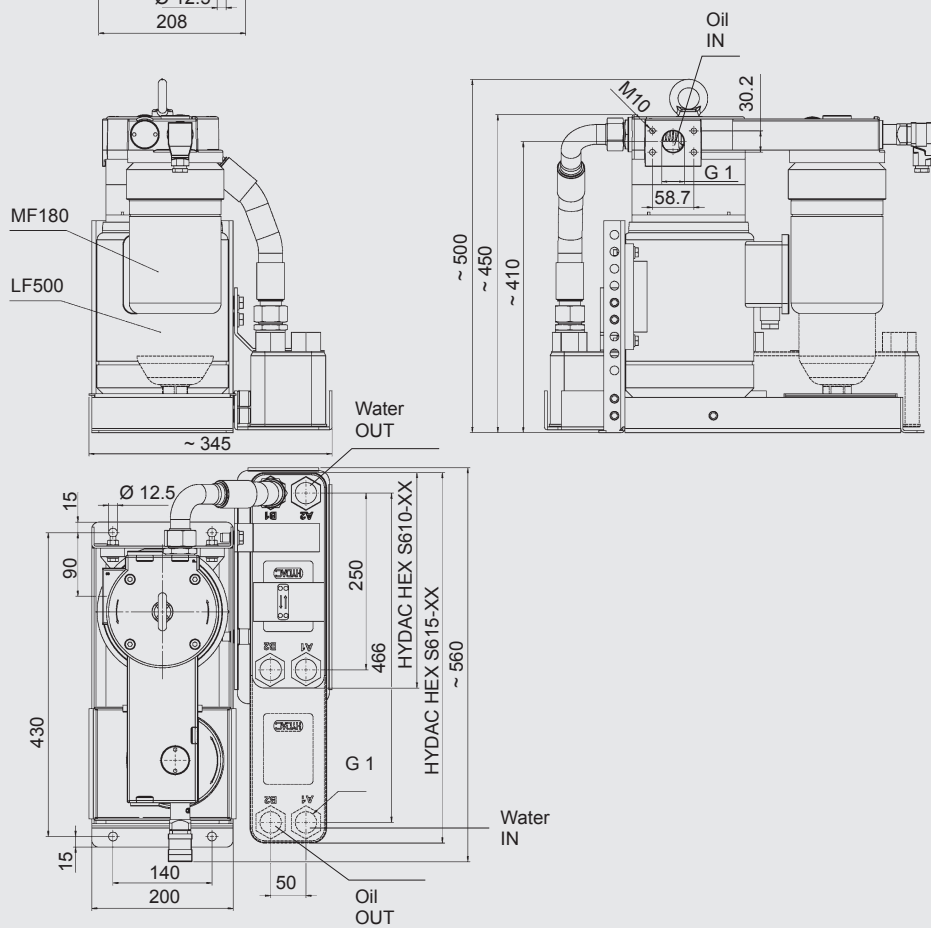

Weight (unfilled)

Motor-pump unit + heat exchanger + filter

Motor-pump unit	Heat exchanger	Filter
0.75 kW: 16 kg	610-20: 11 kg	MF180: 2 kg
1.5 kW: 20 kg	610-40: 14 kg	LF330: 5 kg
	615-20: 14 kg	LF500: 7 kg
	615-40: 18 kg	

UKF-3

UF-3

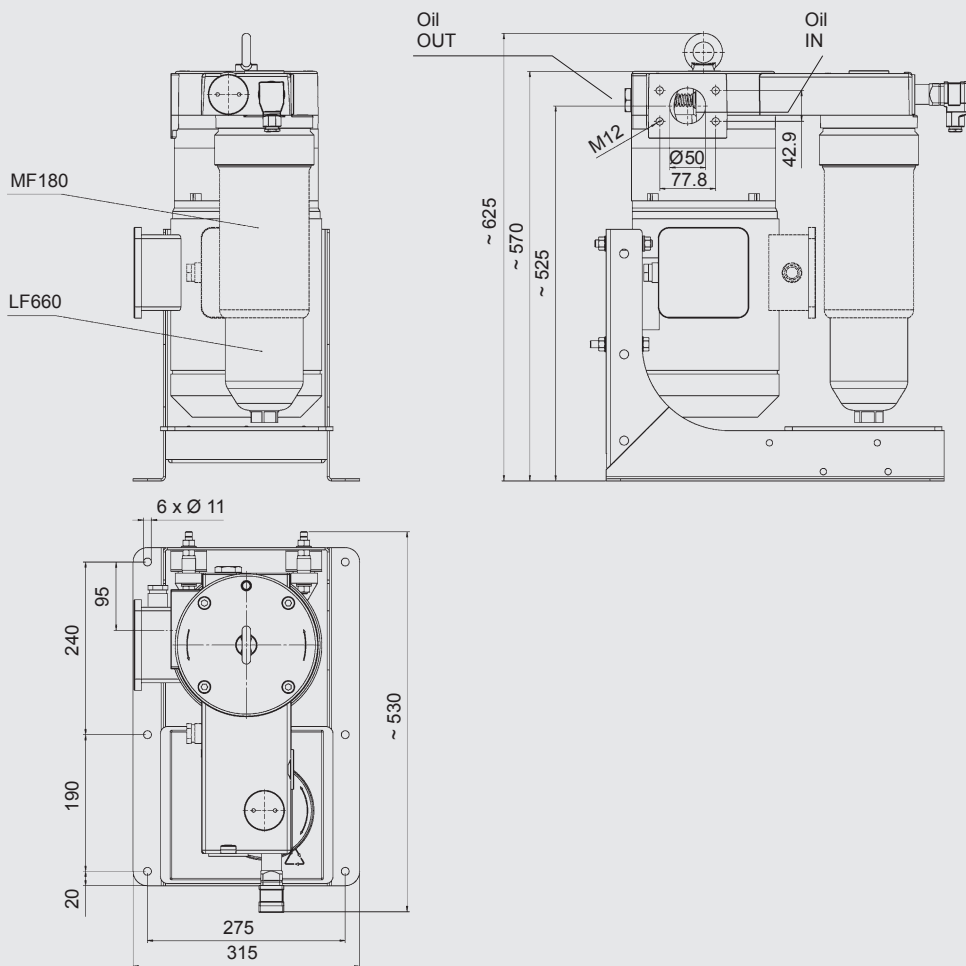

UKF-3

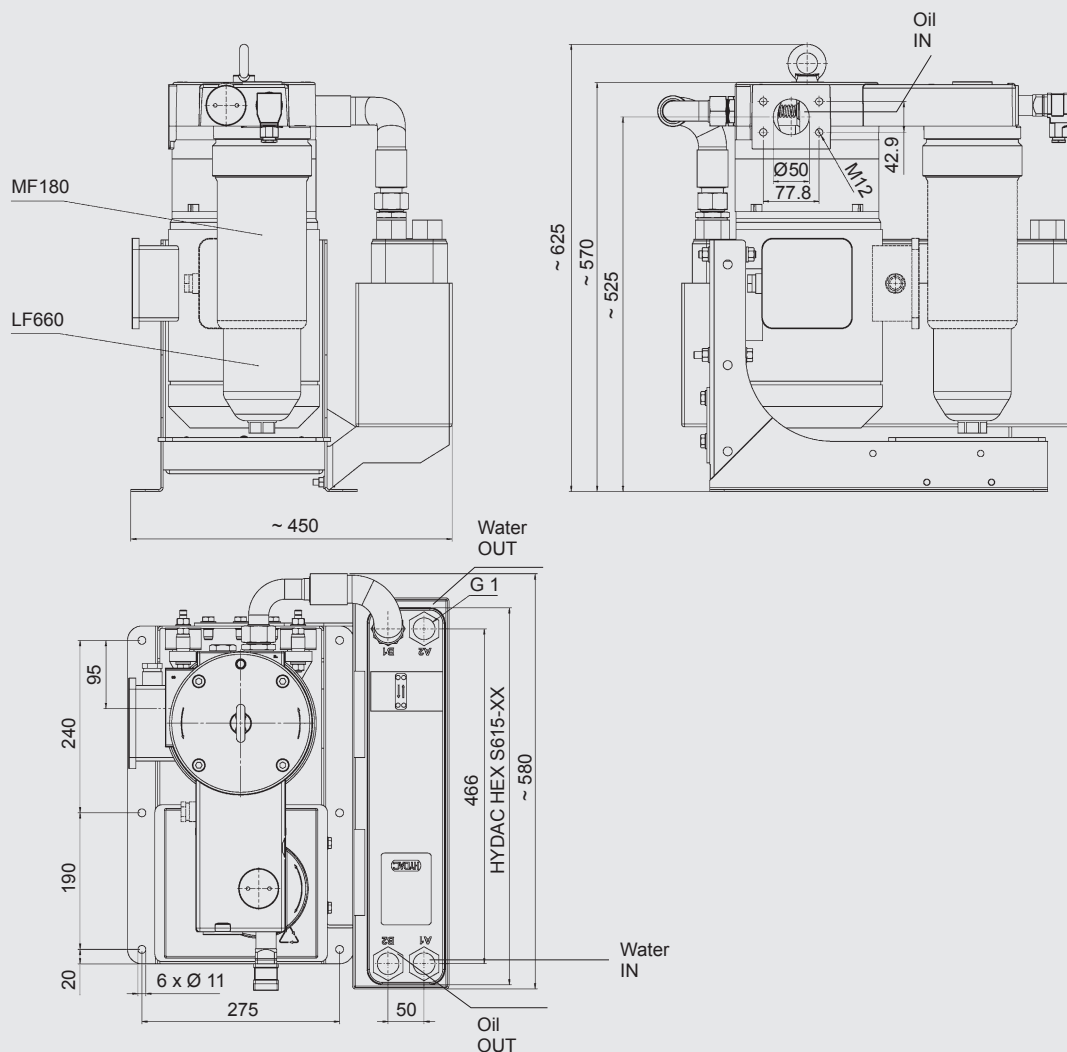

UKF-3

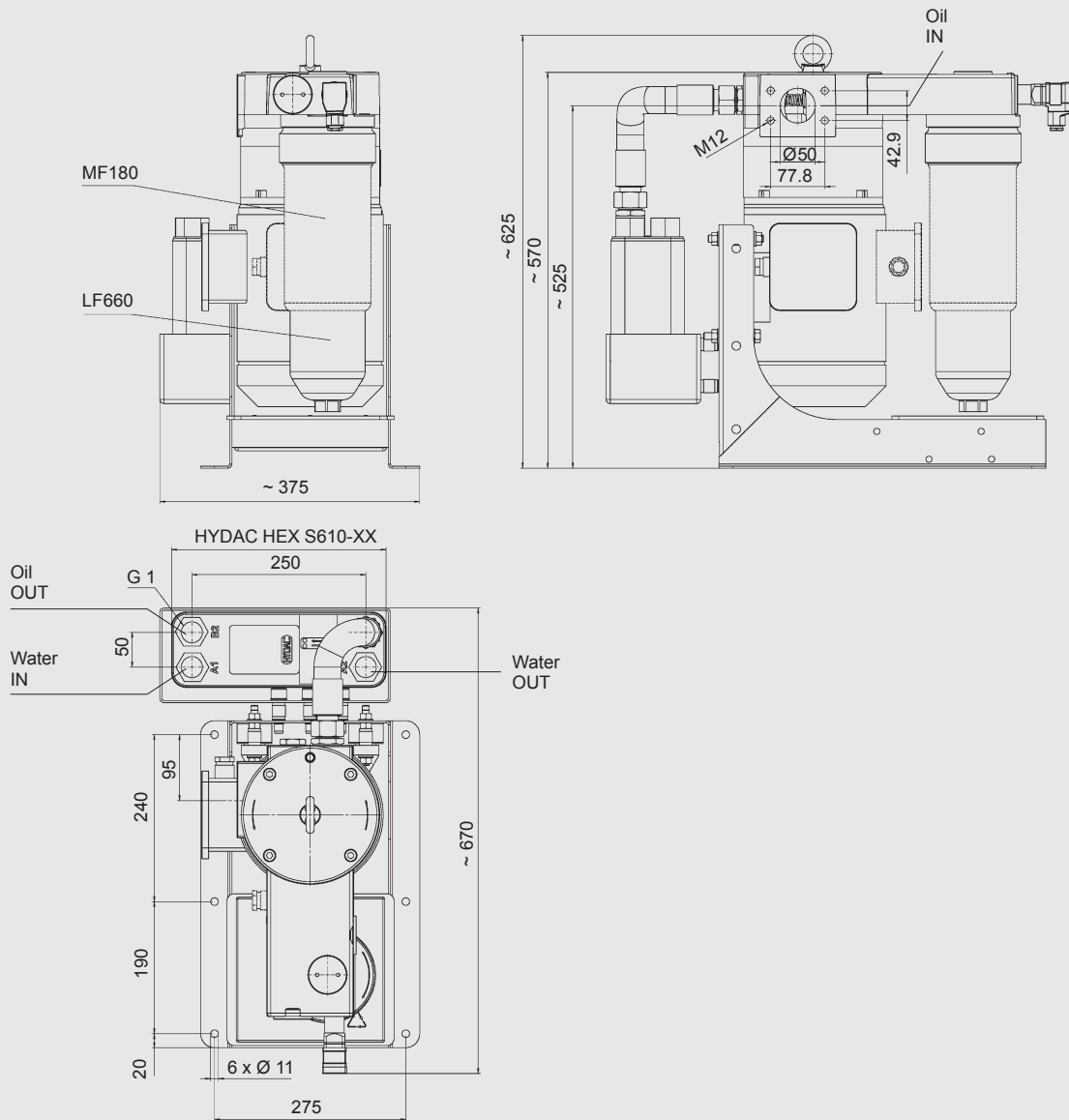

Weight (unfilled)

Motor-pump unit + heat exchanger + filter

Motor-pump unit	Heat exchanger	Filter
1.5 kW: 44 kg	610-20: 11 kg	MF180: 2 kg
2.2 kW: 48 kg	610-40: 14 kg	LF330: 5 kg
4 kW: 52 kg	610-70: 17 kg	LF500: 7 kg
	610-100: 22 kg	LF660: 8 kg
	610-120: 25 kg	
	615-20: 14 kg	
	615-40: 18 kg	
	615-60: 24 kg	
	615-80: 30 kg	

Model Type

UKF-2 - 1.0 - P - 40 - 1.5 - 610-40 - MF180 - 10 - D

Type

UKF = Pump + heat exchanger + filter
 UF = Pump + filter
 UK = Pump + heat exchanger

Version

1.0 = Heat exchanger series 610
 2.0 = Heat exchanger series 615
 1.2 / 2.2 = With filter bypass

Seals

P+V = Static seal Perbunan + Dynamic seal Viton
 P = Static and dynamic seal Perbunan

Pump flow rate: cm³/revolution

	cm ³ /revolution	1,000 1/min	1,500 1/min
UKF-1	3.5		5 l/min
	5		7.5 l/min
	7		10 l/min
	10		15 l/min
UKF-2	15	15 l/min	20 l/min
UKF-2 / UKF -3	20	20 l/min	30 l/min
	30	30 l/min	45 l/min
	40	40 l/min	60 l/min
UKF-3	50	50 l/min	75 l/min
	60	60 l/min	90 l/min
	70	70 l/min	105 l/min
	100	100 l/min	150 l/min
	130	130 l/min	180 l/min

Motor

UKF-1	0.37 kW	@ 1,500 1/min
	0.55 kW	@ 1,500 1/min
UKF-2	0.75 kW	@ 1,500 1/min
UKF-2 / UKF -3	1.1-6p kW	@ 1,000 1/min (6-pole motor)
	1.5 kW	@ 1,500 1/min
UKF-3	2.2 kW	@ 1,500 1/min
	2.2-6p kW	@ 1,000 1/min (6-pole motor)
	4 kW	@ 1,500 1/min

Plate heat exchanger – No. of plates

610	-10	-20	-30	-40	-50	-60	-70	-100	-120
UKF-1	•	•							
UKF-2		•	•	•					
UKF-3		•		•	•	•	•	•	•

615	-10	-20	-30	-40	-60	-80
UKF-1	•	•				
UKF-2		•	•	•		
UKF-3		•		•	•	•

Other plate heat exchangers on request.

Filter

	N5AM/DM	MF160	MF180	LF330	LF500	LF660
UKF-1	•	•	•			
UKF-2			•	•		
UKF-3			•	•	•	•

Filtration rating

-03 = 3 µm
 -05 = 5 µm
 -10 = 10 µm
 -20 = 20 µm

For further details on filter elements, see relevant brochure in Fluid Filters catalogue

Differential pressure of clogging indicator

D = visual-electrical

Additional clogging indicators on request, see relevant brochure in Fluid Filters catalogue

Pump-Transfer Cooler Filtration Unit Selection

Determining the cooling capacity

Estimating the cooling capacity requirements for mineral oil based on increase in tank temperature

$$p = \frac{\Delta T \times V}{t} \times \frac{1}{35}$$

p = heat dissipation [kW]

ΔT = temperature increase in the reservoir [K]

V = tank capacity [l]

T = operating time [min]

Example:

In an system, the tank temperature rises from +20 °C to +70 °C (= 50 K) in 30 minutes.

The tank volume is 100 l.

$$p = \frac{50 \times 100}{30} \times \frac{1}{35}$$

$$p = \underline{4.8 \text{ [kW]}}$$

Estimating the cooling capacity requirement based on installed electrical power

$p \approx \frac{1}{4} \times$ installed electrical power

Calculating the oil and water outlet temperature

Drop in oil temperature:

$$\Delta T \approx \frac{p}{Q_{\text{Oil}}} \times 36$$

Increase in water temperature:

$$\Delta T \approx \frac{p}{Q_{\text{Water}}} \times 14.4$$

p = Cooling capacity [kW]

Q_{Oil} = Oil flow rate [l/min]

Q_{Water} = Water flow rate [l/min]

Selection of the plate heat exchanger:

A sizing program is available to calculate accurately the required cooling capacity and a suitable plate heat exchanger. For this, five of the following seven variables are required:

- Oil inlet and outlet temperature
- Oil flow rate
- Water inlet and outlet temperature
- Water flow rate
- Cooling capacity

Additionally, the viscosity of the oil is required.

The following graphs show the selection of plate heat exchangers based on cooling capacity.

UKF-1

Operating condition: $T_{Oil} = +55\text{ }^{\circ}\text{C}$; oil ISO VG 46; $\frac{Q_{Oil}}{Q_{Water}} = 1$

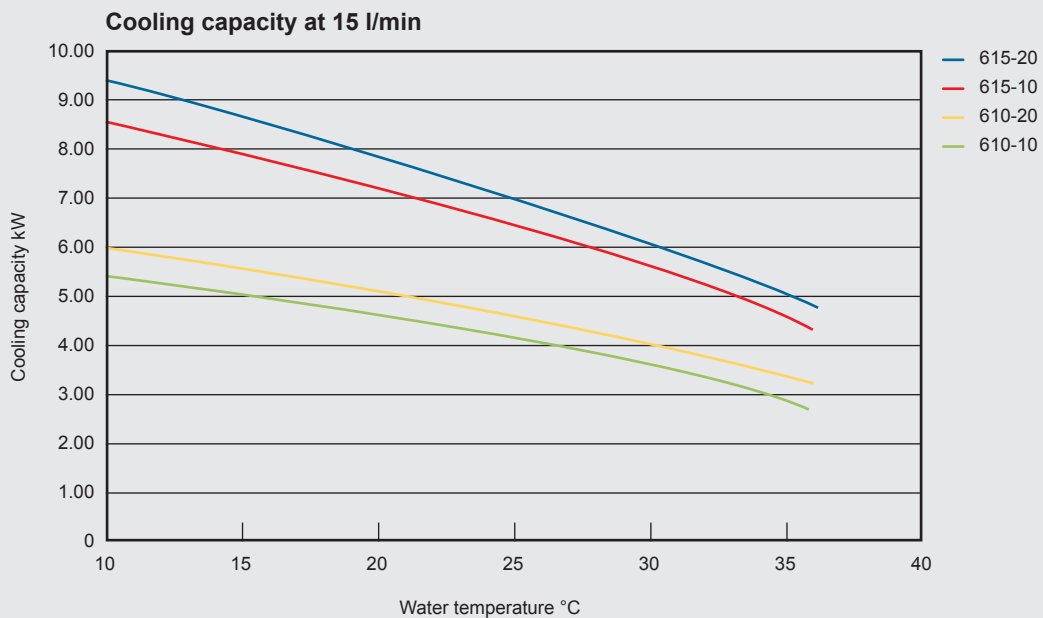
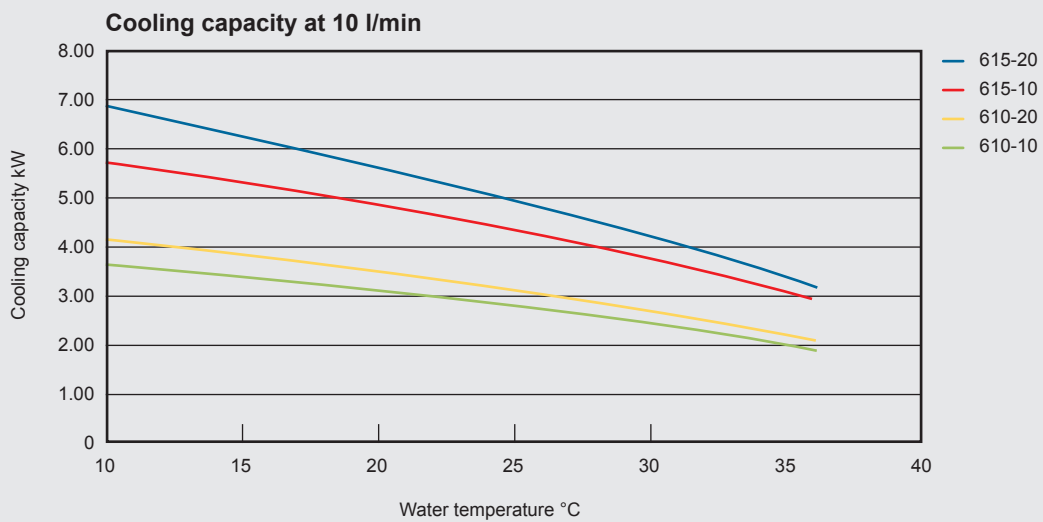
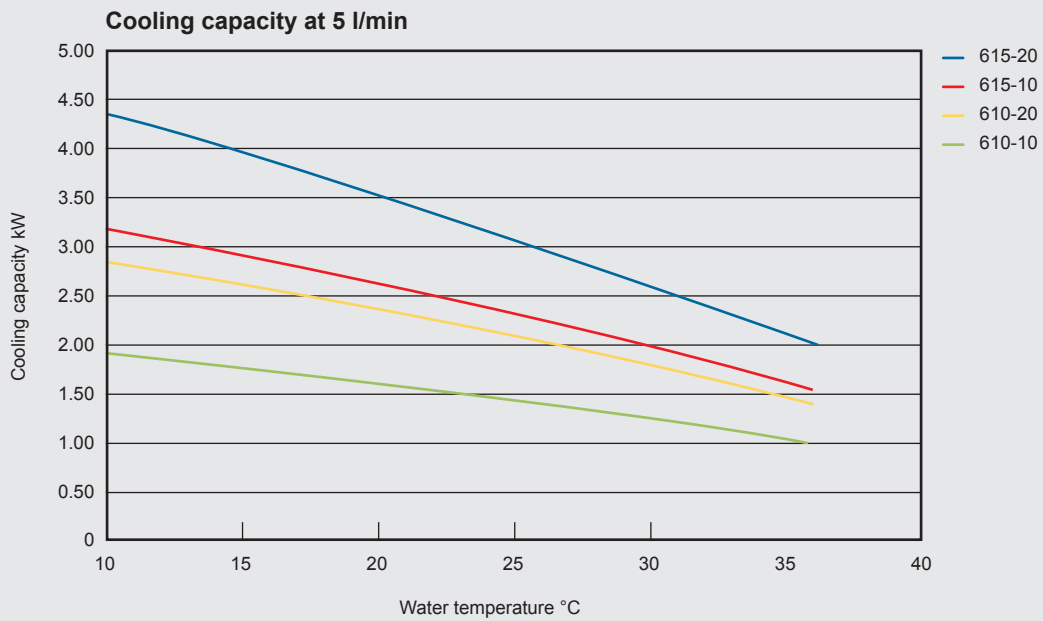

UKF-2

Operating condition: $T_{Oil} = +55\text{ }^{\circ}\text{C}$; oil ISO VG 46; $\frac{Q_{Oil}}{Q_{Water}} = 4$

Cooling capacity at 20 l/min

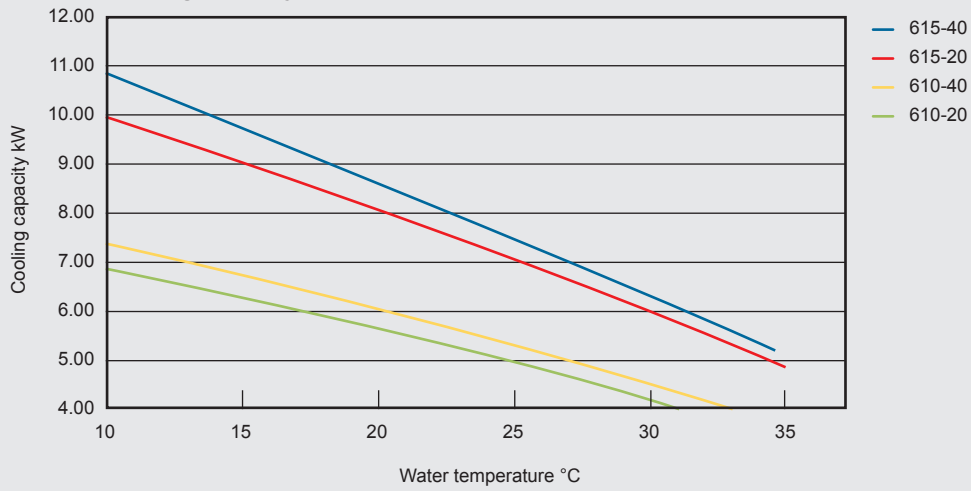

Cooling capacity at 45 l/min

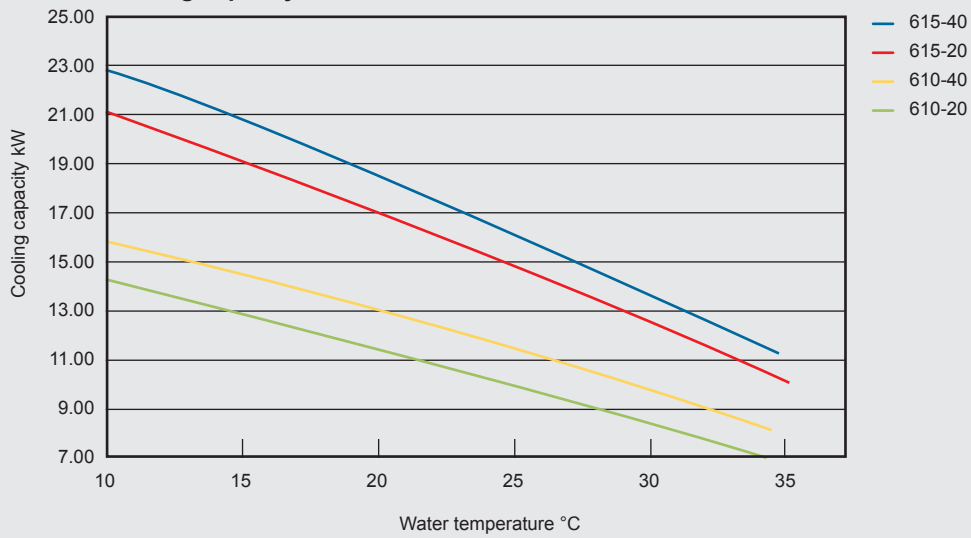

Cooling capacity at 60 l/min

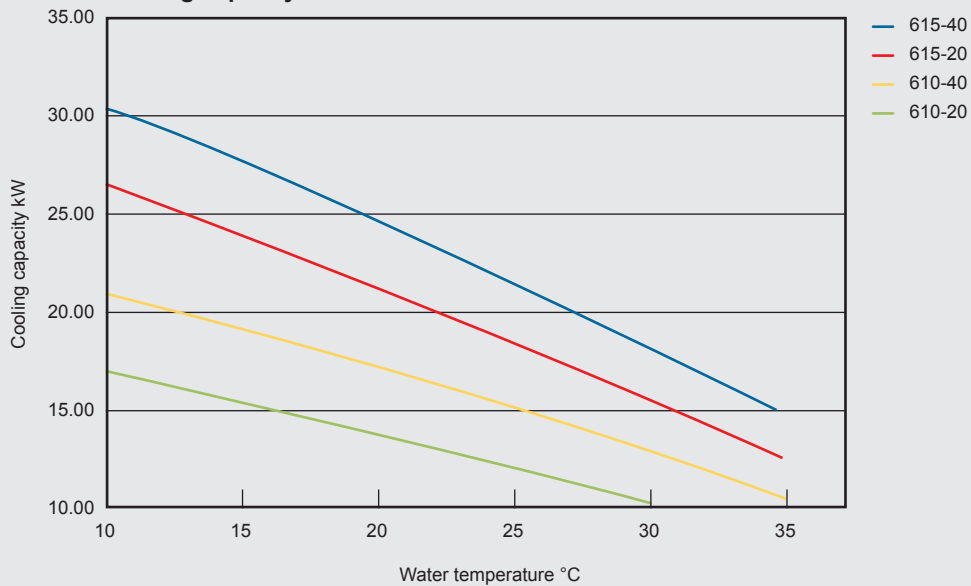

UKF-3

Operating condition: $T_{Oil} = +55\text{ °C}$; oil ISO VG 46; $\frac{Q_{Oil}}{Q_{Water}} = 4$

Cooling capacity at 45 l/min

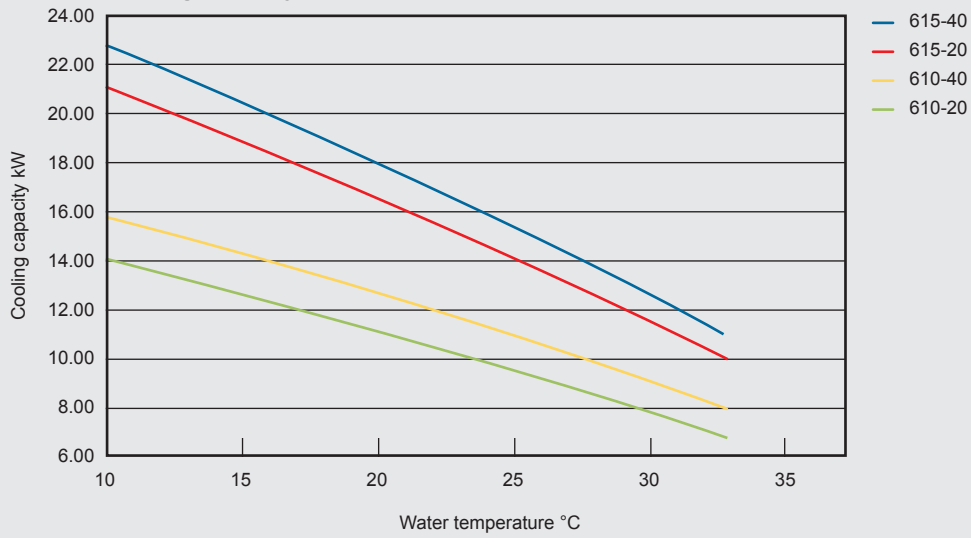

Cooling capacity at 105 l/min

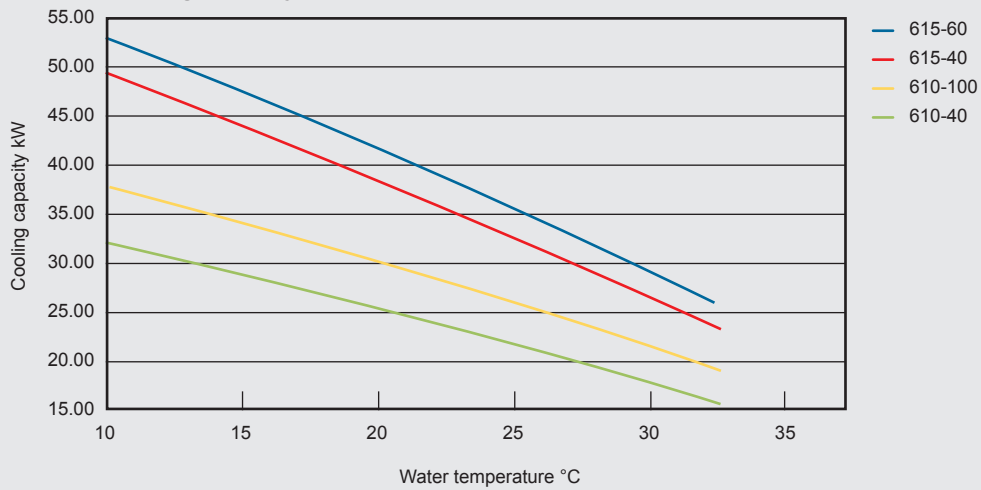

Cooling capacity at 185 l/min

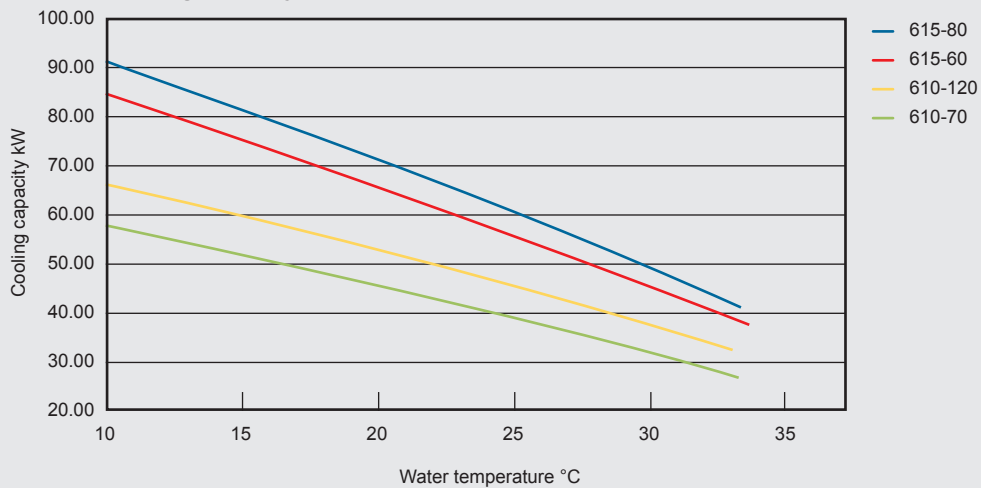

Viscosity

Viscosity / temperature graph
to DIN 51519 Viscosity index 50

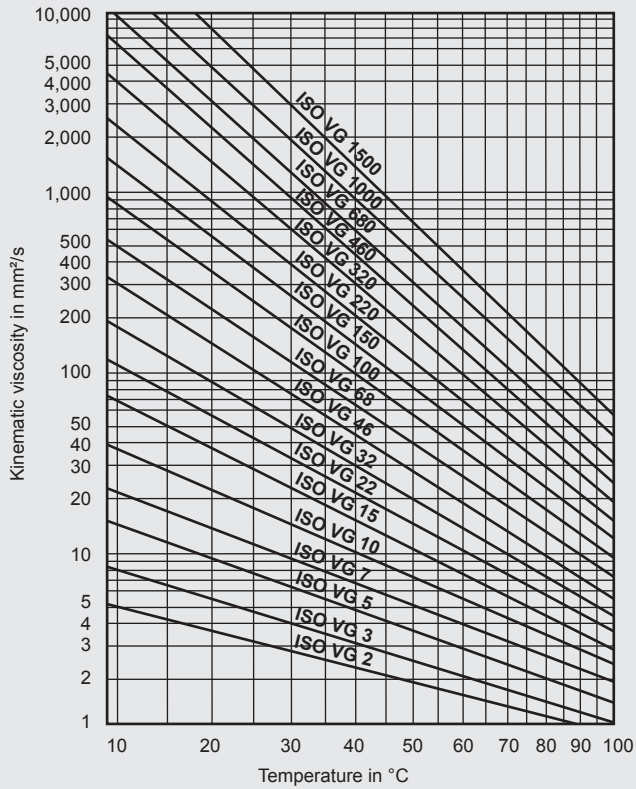

Viscosity / temperature graph
Viscosity index 0 to 200 oil ISO VG 320

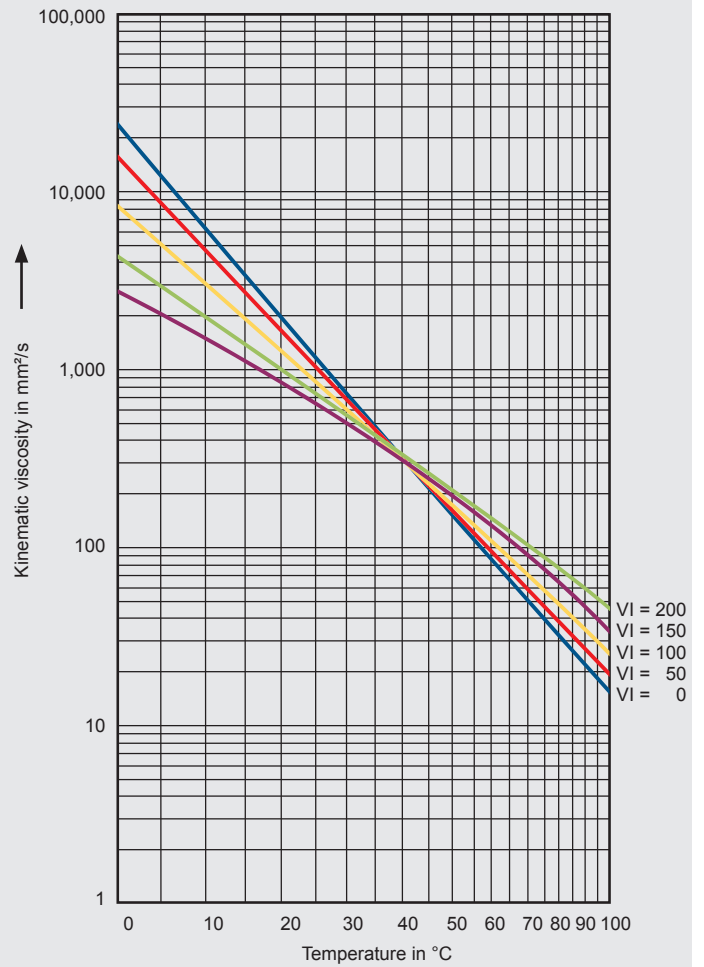

To DIN 51519, viscosity index 50,
Temperature of medium (oil) +10 °C to +80 °C; short-term
operation at higher viscosities (cold start) is permitted.

The viscosity index indicates how much the viscosity of the oil
changes with temperature.

It is a measure of the temperature properties of different oils.
The higher the viscosity index of an oil, the smaller the change
in viscosity in relation to the temperature.

Graphs for Motor-pump Selection

UKF-1

Motor: 0.2 kW DC

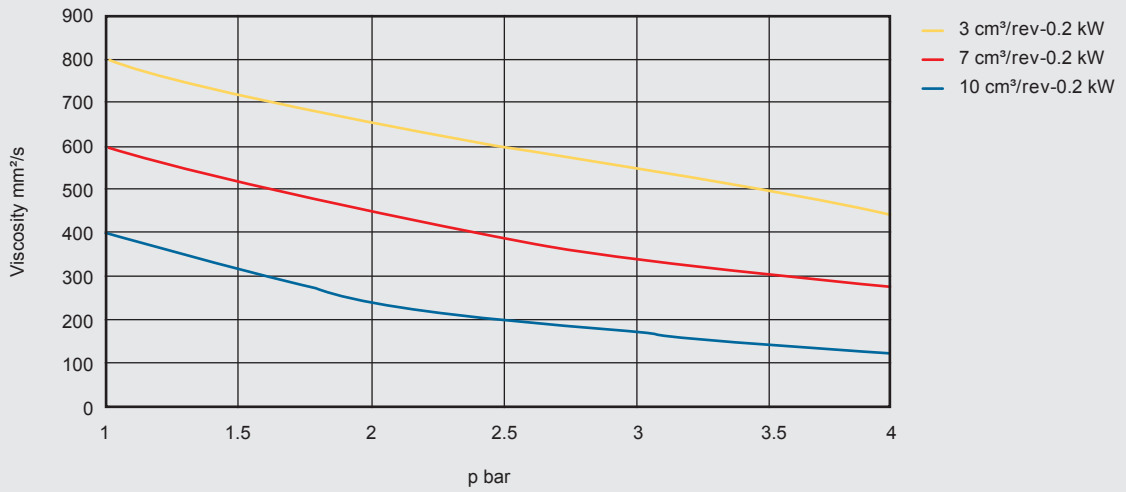

Motor: 0.37 kW

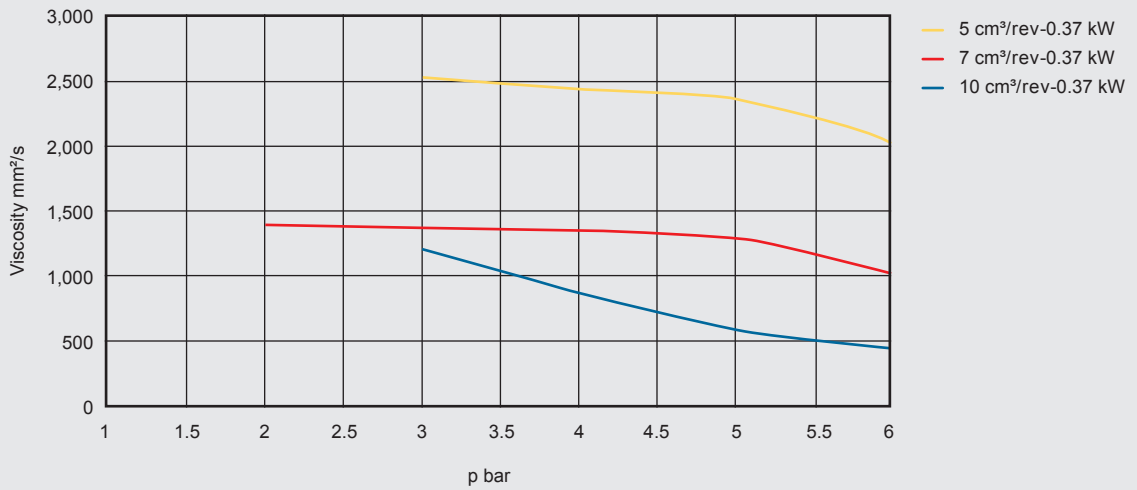

Motor: 0.75 kW

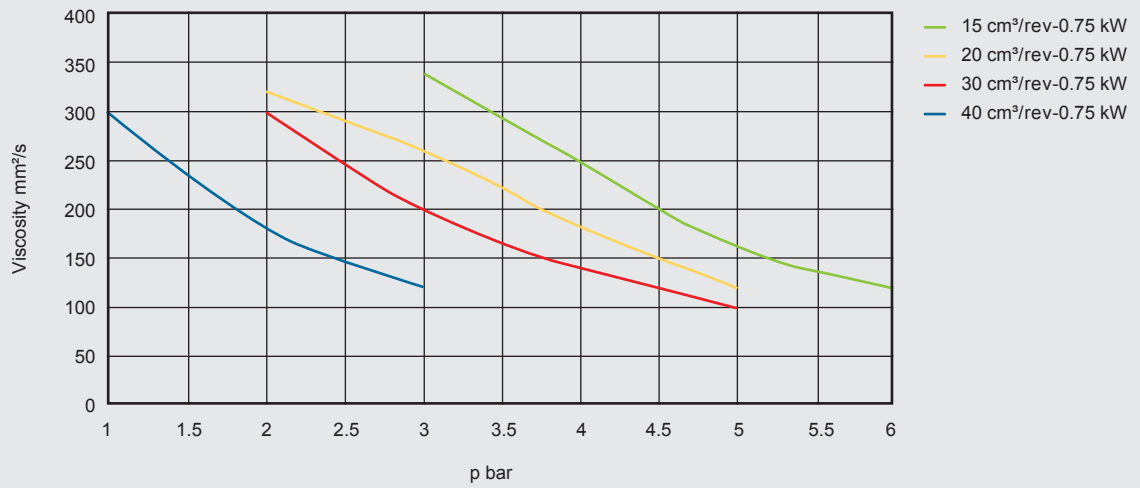

Motor: 1.5 kW

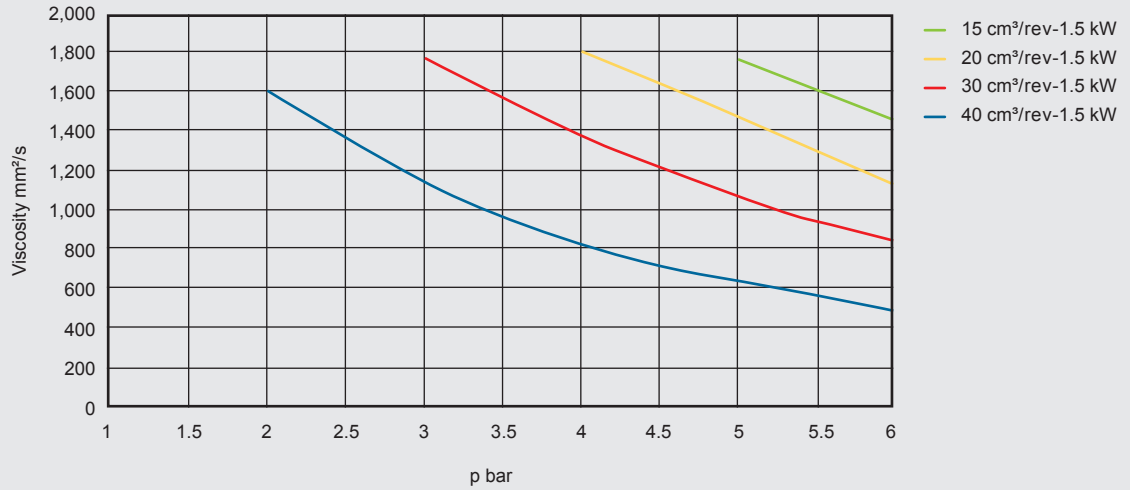

Motor: 2.2 kW

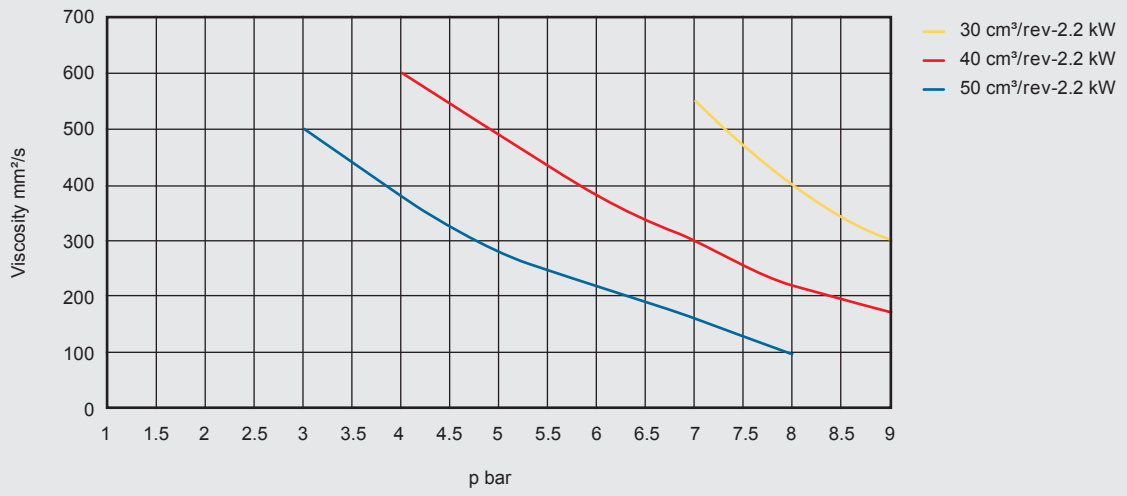

Motor: 4 kW

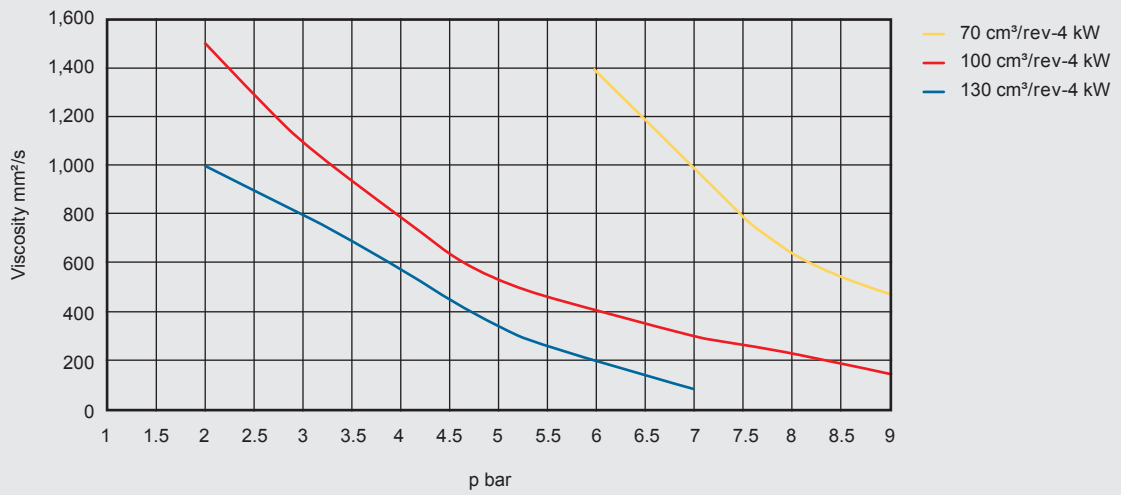

Notes

On piping

The pressure differential in a hydraulic line is dependent on:

- Flow rate
- Kinematic viscosity
- Pipe dimensions and can be estimated for hydraulic oils as follows:

$$\Delta p[\text{bar}] = 5.84 \times \frac{l [\text{m}]}{d^4 [\text{mm}]} \times Q \times \nu [\text{bar}]$$

l = Pipe length [m]

d = Internal diameter of pipe [mm]

Q = Flow rate [l/min]

ν = Kinematic viscosity [mm²/s]

This applies to straight pipe runs and hydraulic oils, and to laminar flow.

Additional threaded connections and pipe bends increase the pressure differential.

Notice

- As few threaded connections as possible
- Few pipe bends; if unavoidable, use large radius
- Difference in height between pump and oil level as small as possible
- Hoses must be suitable for a vacuum of min. 5,000 mmW
- Do not reduce pipe cross-section predetermined by the unit

Note

The information in this brochure relates to the operating conditions and applications described. For applications and operating conditions not described, please contact the relevant technical department. Subject to technical modifications.

HYDAC

HYDAC COOLING GMBH

INTERNATIONAL

Industriegebiet
66280 Sulzbach/Saar
Germany

Tel.: +49 6897 509-01
Fax: +49 6897 509-454

E-mail: cooling@hydac.com
Internet: www.hydac.com

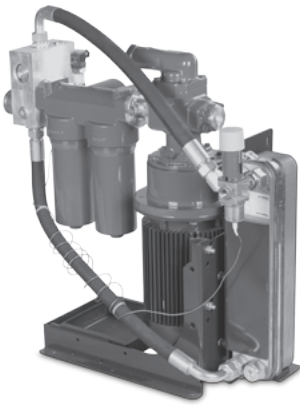

Pump-Transfer Cooler Filtration Unit UKF for Gearboxes

Symbol

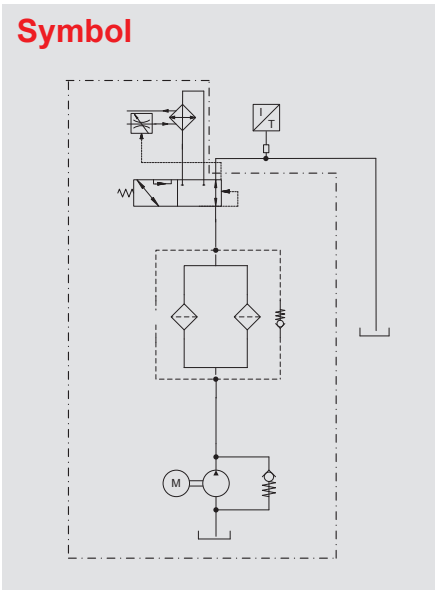

General

This pump transfer cooler filtration unit (UKF) has been specially designed for cooling and lubricating stationary gearboxes. It consists of a gear pump, a filter and a plate heat exchanger. Its compact design enables quick, simple integration into the offline circuit.

Application Field

- Cooling and lubrication of gearboxes

Operating Data

General	
Ambient temperature	-20 °C to +40 °C
Mounting position	Vertical
Pump	
Suction pressure across suction port	Max. -0.4 bar to 3 bar
Operating pressure (oil side)	Max. 16 bar
Medium (oil side)	Mineral oil to DIN 51524 Part 1 and Part 2
Temperature range (oil side)	-10 °C to +80 °C
Permissible contamination (oil side)	≤NAS12 or ISO4406: 22/21/18
Max. viscosity	20,000 mm ² /s, depending on the motor rating
Drive	
Motor	Three-phase electric motor Insulation class: F Protection class: IP 55
RPM	1,000 / 1,500 1/min (50 Hz)
Heat exchanger	
Construction	<ul style="list-style-type: none"> ● Copper brazed plate heat exchanger HYDAC HEX S (standard) ● Gasketed plate heat exchanger (on request)
Medium (water side):	<ul style="list-style-type: none"> ● Water glycol (HFC) ● Water ● Oils
Temperature range (water side)	+5 °C to +60 °C
Permissible contamination (water side)	The level of particles in suspension should be less than 10 mg/l Particle size <0.6 mm (spherical) Thread-like particles cause a rapid increase in pressure drops

Product Features

Continuous cooling and offline filtration extend the service life of the oil and of the gears. The duplex filter enables the filter to be changed without switching off the unit. In addition, there is an integrated thermal bypass valve which ensures that the system continues to run even at low temperatures because the cold oil is not fed through the plate heat exchanger. Once the oil is warm enough it can flow through the heat exchanger to cool the unit.

To guarantee a constant oil temperature an optional water flow controller can be fitted which supplies just enough water to the plate heat exchanger as is necessary to achieve the required oil temperature. Pressure, temperature or flow rate sensors can also be added to the control block.

Design

Different versions are possible depending on the requirements:

UF – Feed pump with filter

UKF – Feed pump with filter and plate heat exchanger

Offline unit consisting of:

- Gear pump
- Filter (duplex filter available as an option)
- Oil-water plate heat exchanger (brazed or gasketed)
- Thermal bypass valve (UKF-2 / UKF-3)
- The offline circuit is fitted with check valves to isolate the filter when used with a positive head tank when changing the filter element

UKF-1



Flow rate:	2.5 – 14 l/min
------------	----------------

Motor rating:	0.55 kW
---------------	---------

Cooling capacity*:	1 – 10 kW
--------------------	-----------

UKF-2

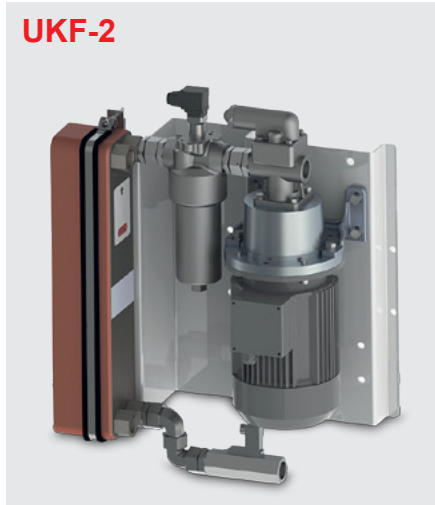

Flow rate:	15 – 30 l/min
------------	---------------

Motor rating:	0.75 – 1.5 kW
---------------	---------------

Cooling capacity*:	5 – 20 kW
--------------------	-----------

UKF-3



Flow rate:	30 – 100 l/min
------------	----------------

Motor rating:	1.5 – 5.5 kW
---------------	--------------

Cooling capacity*:	10 – 75 kW
--------------------	------------

* Dependent on temperature difference and flow rate of the cold and warm medium

Model Type

UKF-3 - 5.2 - P+V - 32 - 2.2 - 615-80 - FLND400 - 10 - D

Type

UKF = Pump + heat exchanger + filter
UF = Pump + filter

Size

1 / 2 / 3

Modification code

Seals

P+V = Static seal Perbunan + dynamic seal Viton
P = Static and dynamic seal Perbunan

Pump flow rate in ccm³/rev

Motor

0.55 kW / 0.75 kW / 1.5 kW / 2.2 kW / 4 kW

Plate heat exchanger

Size 610 – 10-100 plates
Size 615 – 10-100 plates
Other sizes and gasketed plate heat exchangers on request.

Filter

Inline filter HFM75 / FLN 250 / FLN 400
Duplex filter FLND 250 / FLND 400
with filter bypass

Filtration rating in µm

For further information on filter elements, see Filtration catalogue.

Differential pressure clogging indicator

D = VM 5 D.0 / -L24 (5 bar; visual-electrical)
Other clogging indicators on request.
For further information, see Filter Clogging Indicator brochure

Note

The information in this brochure relates to the operating conditions and applications described.

For applications and/or operating conditions not described, please contact the relevant technical department.

Subject to technical modifications and corrections.



HYDAC COOLING GMBH

INTERNATIONAL

Industriegebiet
66280 Sulzbach/Saar
Germany

Tel.: +49 6897 509-01
Fax: +49 6897 509-454

E-mail: cooling@hydac.com
Internet: www.hydac.com

Fluid Cooling Systems FLKS / FWKS / RFCS / HCC

General

The heat arising from internal thermal loss in main spindles, drives, control cabinets, cooling lubricants and hydraulics can be channelled away very effectively by fluid cooling.

Using HYDAC chiller systems with air cooling, water cooling or compressor cooling allows all requirements to be fulfilled and a constant cooling temperature to be achieved.

Energy-efficient control systems, such as the speed control used for fan drives, not only reduce noise levels but also provide significant energy savings.

Performance-controlled compressor cooling units allow operation to be adjusted to suit requirements, saving energy while achieving temperature control accuracy of ± 0.2 K. Using the patented mixer-valve system in conjunction with an immersion pump allows this exact set-up to be realized inexpensively and with precise regulation.

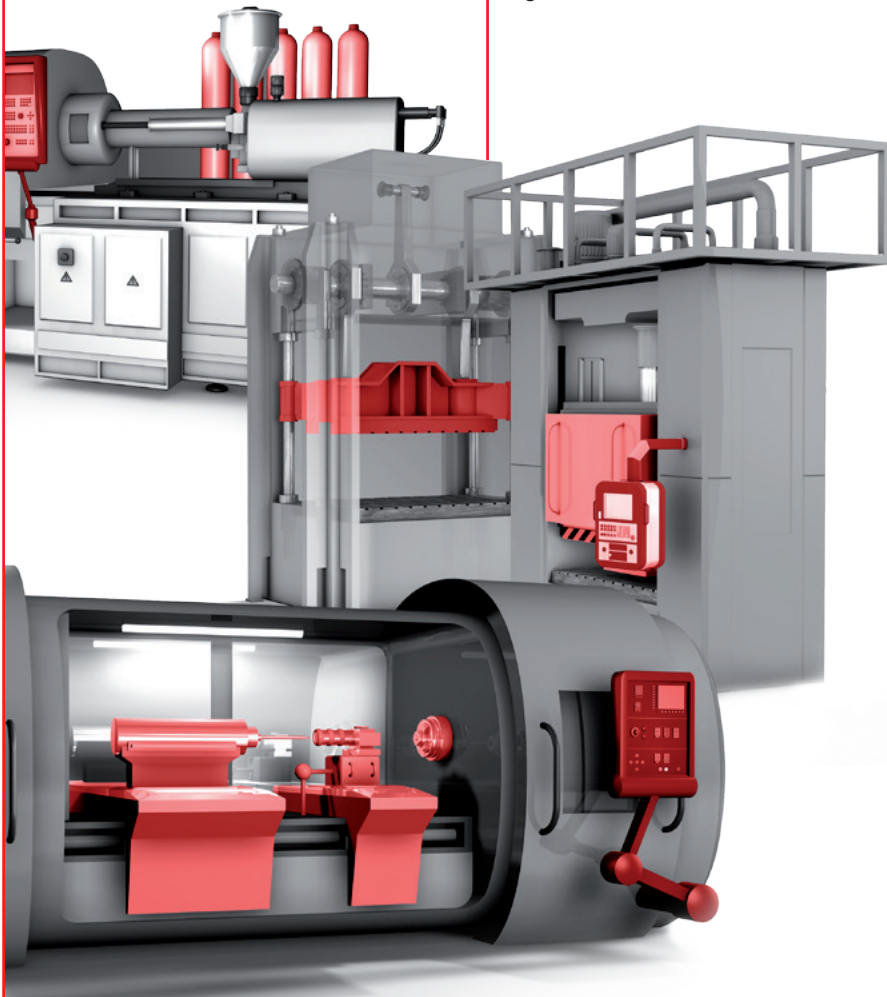



FLKS-2EC



FLKS-8EC



FWKS-2/2.x



FWKS-5/1.x

FLKS Fluid/Air Cooling Systems

Features

- Cooling of circuits which use mineral oil or water glycol
- Compact design with plastic tank, circulation pump, cooling element and fan
- Various sizes with cooling capacities up to 4.5 kW/K and flow rates up to 300 l/min

Function

The pump conveys the cooled operating fluid from the tank through the component that is to be cooled. The fluid absorbs heat from the component and then flows back to the heat exchanger, where it is returned to a cooler temperature by the air flowing from the installed fan.

Advantages

- Cost-effective and efficient cooling system
- Using immersion pumps
- Sizes FLKS-1, FLKS-2, FLKS-3, FLKS-4 and FLKS-5 with plastic tank housing; tank content > 110 l with stainless steel tank (FLKS-8 and FLKS-10)
- Energy-efficient thanks to optimized and adjusted drives and the heat being released directly to the surroundings
- Speed-controlled systems:
The temperature of the operating fluid is controlled by adjusting the fan speed with a set difference to the ambient temperature. The speed control is integrated as standard for sizes FLKS-8 and -10.

FWKS Fluid/Water Cooling Systems

Features

- Cooling of circuits which use mineral oil or water glycol
- Compact design with plastic tank or stainless steel tank, circulation pump and plate heat exchanger
- Various sizes with cooling capacities up to 250 kW and flow rates up to 300 l/min
- Can be used as a temperature-controlled intermediate circuit. In this way the contamination and corrosion in the coolant circuits which could arise as a result of direct cooling with poor water quality is prevented.

Function

The pump conveys the cooled operating fluid from the tank through the component that is to be cooled. Once there, it absorbs the heat. It then flows back to the plate heat exchanger, where it is returned to a cooler temperature by the cooling water.

Advantages

- Cooling to below ambient temperatures also possible (depending on temperature of the cooling fluid)
- Using immersion pumps
- Low release of heat to surroundings and low noise emission
- Thermostatically or electronically controlled proportional valve or control ball valve available as an option: the temperature of the operating fluid can thus be maintained at a specific temperature value.



RFCS Compressor Coolers

Features

- Fluid cooling system as separate auxiliary cooler or for integration into a machine
- Cooling capacities from 1 to 160 kW
- Can be used for any cooling tasks
- Stand-alone control of the system by means of innovative controller design
- Condenser available as water-cooled or air-cooled variant
- Several cooling circuits possible
- Precise temperature control accuracies from ± 0.1 K

Function

The RFCS refrigerated fluid chiller system allows various fluids such as water, water glycol and oil to be cooled. The chiller system consists of refrigerator, pump, tank and controller and is able to set the temperature of the operating fluid to a previously configured target value independently.

The energy-efficient, patented mixer principle, combined with a sealless submersible pump, makes this system the ideal component for your machine tool.

Advantages

- Target temperature can be set at or below ambient temperature
- Leak-free immersion pump
- Compact dimensions
- User-friendly controller interface
- Cleanable air filter
- Plug & Play solution
- Easy to service and user-friendly



HCC Control Cabinet Cooler

Features

- Control cabinet cooler for roof installation or wall/door mounting
- Cooling capacities from 0.1 to 15 kW
- For all cooling applications in switchgears and control cabinets
- Stand-alone control of the system by means of innovative controller design
- Air/air or air/water coolers are also available

Function

The HCC control cabinet cooler system is flexible in its installation and designed to cool control cabinets. Special heat exchanger designs ensure energy-efficient operation and a high level of operating reliability.

Regardless of the version used, whether air/air, air/water or refrigeration, the HCC series ensures optimal conditions and improved service life for electronic components.

Advantages

- Compact design
- Innovative heat exchanger designs
- Optimal condensate separation
- User-friendly controller interface
- Plug & play solution

Note

The information in this brochure relates to the operating conditions and applications described.

For applications and operating conditions not described, please contact the relevant technical department.

Subject to technical modifications and corrections.



HYDAC COOLING GMBH

INTERNATIONAL



Industriegebiet
66280 Sulzbach/Saar
Germany

Tel.: +49 6897 509-01
Fax: +49 6897 509-454

E-mail: cooling@hydac.com
Internet: www.hydac.com

Fluid/Air Cooling Systems FLKS

	Cooler type	H x W x D [mm]	Cooling capacity max. [kW/K]	Flow rate [l/min]	Tank [l]
	FLKS-1H	405 x 457 x 276	0.13	2 – 15	7.5
	FLKS-1H+	405 x 483 x 395	0.17	5 – 25	7.5
	FLKS-2S	515 x 620 x 315	0.31	5 – 35	19.5
	FLKS-2EC	550 x 620 x 325	0.33	5 – 35	19.5
	FLKS-3S	708 x 500 x 443	0.46	5 – 40	28.5
	FLKS-3EC	708 x 500 x 443	0.50	5 – 40	28.5
	FLKS-4S	813 x 570 x 485	0.65	10 – 55	43
	FLKS-4EC	813 x 570 x 485	0.70	10 – 55	43
	FLKS-5S	983 x 665 x 622	1.05	5 – 100	70
	FLKS-5EC	983 x 665 x 622	1.15	5 – 100	70

Cooler type	H x W x D [mm]	Cooling capacity max. [kW/K]	Flow rate [l/min]	Tank [l]
 <p data-bbox="497 450 619 477">FLKS-8EC</p>	2,273 x 809 x 807	2.00	150	110
 <p data-bbox="497 936 635 963">FLKS-10EC</p>	2,273 x 1,609 x 807	4.00	300	110

Cooling capacity FLKS-1S – FLKS-5S

At 50 Hz

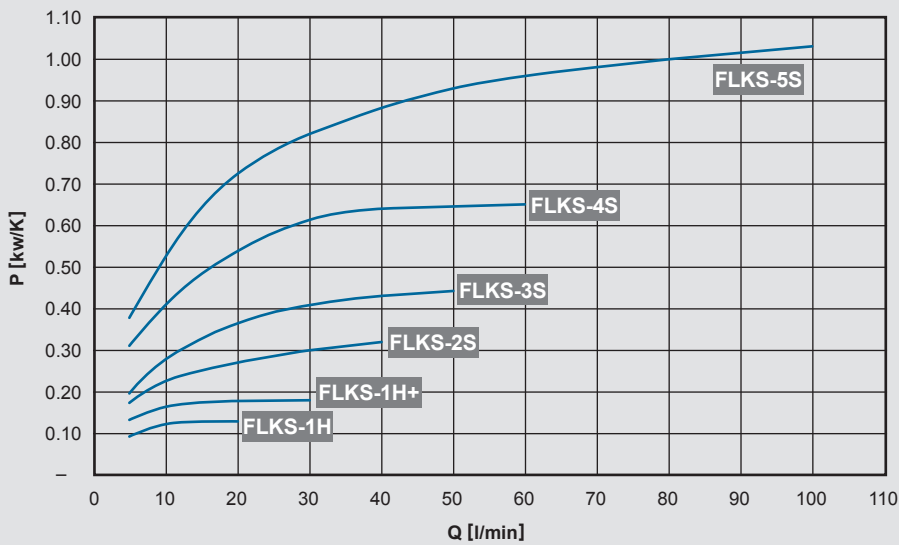

Cooling capacity tolerance: ± 5 %

The cooling capacity is calculated via the following formula:

$$P \text{ [kW]} = P_{\text{spec.}} \text{ [kW/K]} \times \text{ITD} \text{ [K]}$$

ITD (inlet temperature difference) = cooler inlet temperature of operating medium – air inlet temperature

Cooling capacity FLKS-2EC – FLKS-5EC with speed control

At 50 Hz and max. drive speed

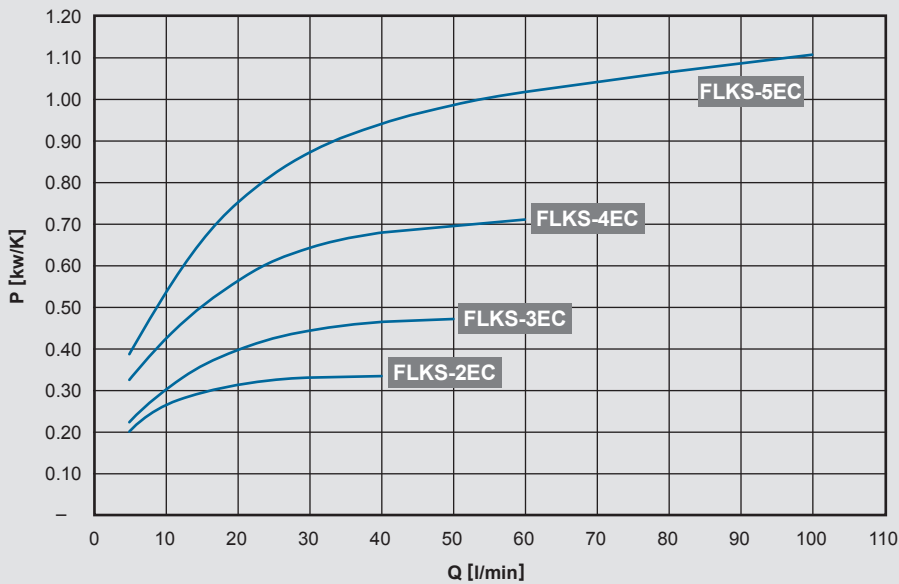

Cooling capacity tolerance: ± 5 %



Fluid/Air Cooling Systems FLKS-1H

Symbol

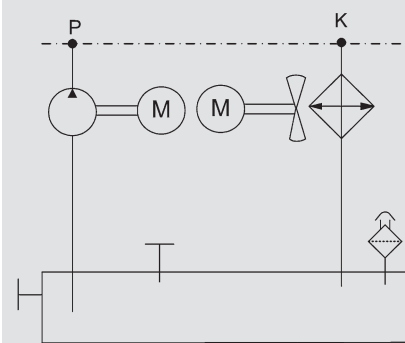

Technical data

Cooling capacity	Max. 0.130 kW/K (see cooling capacity diagram)
Flow rate	2 – 15 l/min (see output diagrams)
Operating fluid	Version with water glycol (W): Potable water with 35 – 40 % ethylene glycol-based or propylene glycol-based antifreeze and anti-corrosion concentration. Other fluids on request (e.g. mineral oil).
Permitted temperatures	Fluid temperature: max. +60 °C Ambient temperature: 0 °C to +45 °C
Tank volume	5.5 – 7.5 l
Weight	Max. 22 kg
Noise (acoustic pressure)	70/72 dB(A) at 50/60 Hz (at 1 m)
Hydraulic connection	Pump P (flow): G $\frac{3}{4}$ " Heat exchanger K (return): G $\frac{3}{4}$ " If possible, refrain from reducing the size of the line required for the threaded connections.
Electrical connection	The motors are usually electrically connected using a heavy-duty connector (connection via terminal box available upon request).
Accessories	<ul style="list-style-type: none"> ● Air filter ● Air duct ● Fill level switch ● Fill level and temperature switch ● Flow switch Combinations and other accessories upon request.

General

The **FLKS-1H** is a compact fluid/air cooling system with a plastic tank housing and integrated air duct. This lightweight and robust design makes it suitable for diverse applications.

Function

The pump conveys the operating medium from the tank through the part being cooled to the heat exchanger. The axial fan provides the necessary air flow through the heat exchanger to cool the operating medium.

Field of application

- Liquid-cooled drives:
motor spindles, torque motors,
servo motors, linear motors
- Inverter cooling
- Gearbox cooling and lubrication
- Bearing cooling
- Tool cooling

Cooling capacity

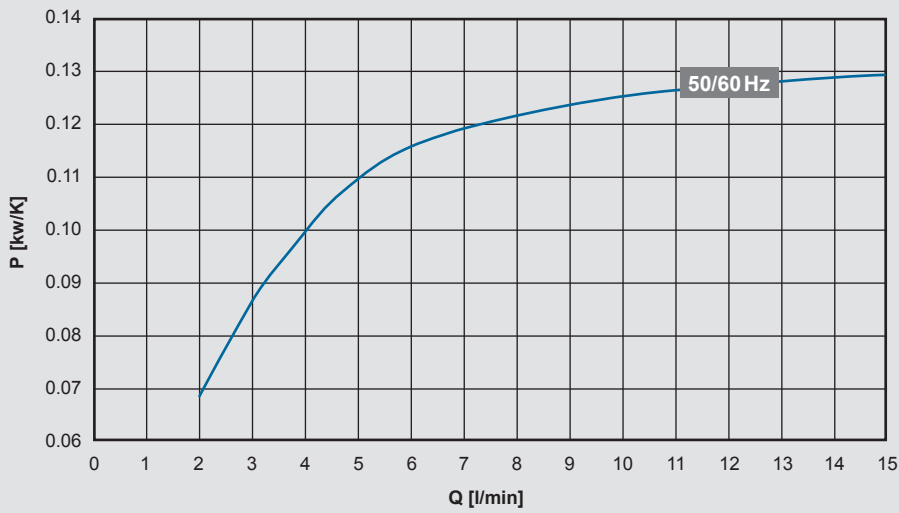

Cooling capacity tolerance: $\pm 5\%$

The cooling capacity is calculated via the following formula:

$$P [\text{kW}] = P_{\text{spec.}} [\text{kW/K}] \times \text{ITD} [\text{K}]$$

ITD (inlet temperature difference) = cooler inlet temperature of operating medium – air inlet temperature

Output data

Version with pump TKY

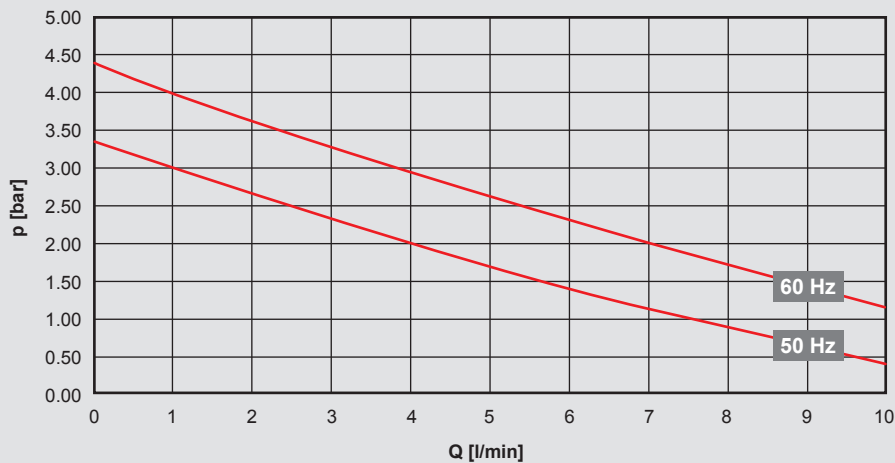

Operating range: 2 – 10 l/min

Electrical data:

Permissible voltage range:

380 – 420 V – 50 Hz – 3 PH
400 – 480 V – 60 Hz – 3 PH
Voltage tolerance +5 % / -10 %

Motor capacity (50/60 Hz):

Pump: 0.12 / 0.18 kW
Fan: 0.11 / 0.15 kW

Version with pump MTA50

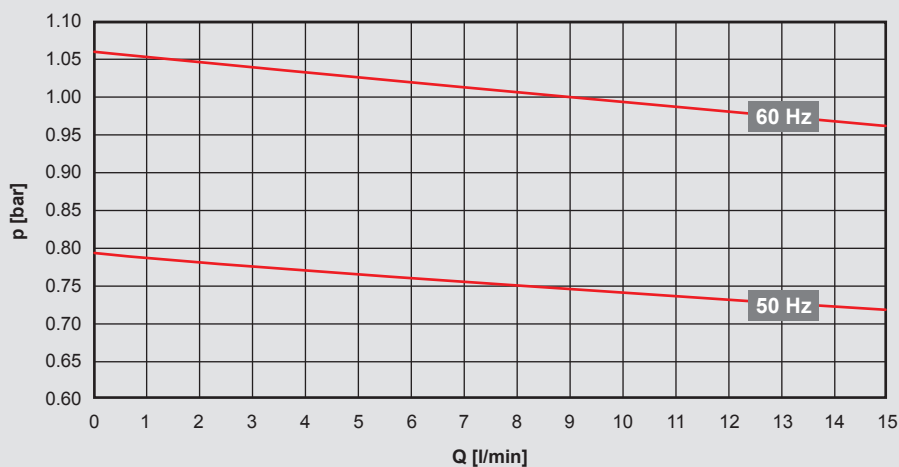

Operating range: 2 – 15 l/min

Output tolerance: $\pm 9\%$, pumping head tolerance: $\pm 7\%$ as per DIN EN ISO 9906 Cl. 2, App. A

Electrical data:

Permissible voltage range:

380 – 415 V – 50 Hz – 3 PH
380 – 480 V – 60 Hz – 3 PH
Voltage tolerance +5 % / -10 %

Motor capacity (50/60 Hz):

Pump: 0.17 / 0.27 kW
Fan: 0.11 / 0.15 kW

Note:

The operating point of the pump (flow rate) depends on the characteristic curve (line sizes, line lengths, screwing elements). In general, the less the system losses, the greater the flow rate and the greater the cooling capacity.

Please contact Technical Sales with questions on cooling capacity and output data with other operating fluids, as well as on special voltages or other pumps.

Electrical connection

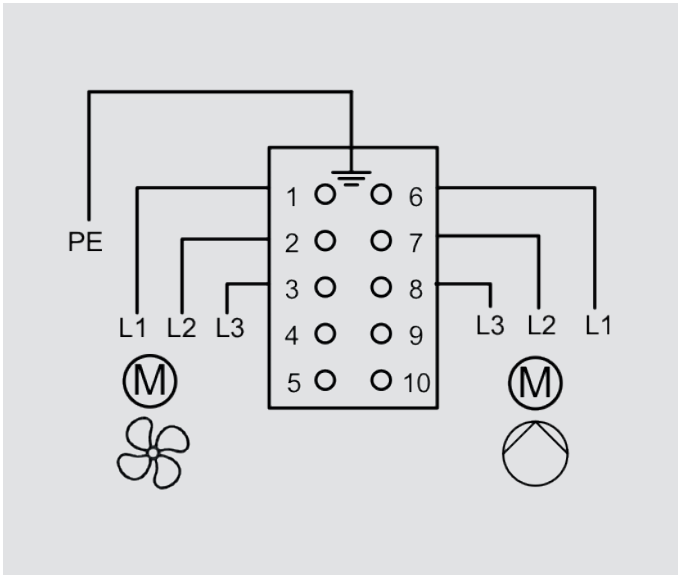

The motor is usually electrically connected using a heavy-duty connector.

E.g. Harting housing 09300101541 and insert 09330102716.

Dimensions

[mm]

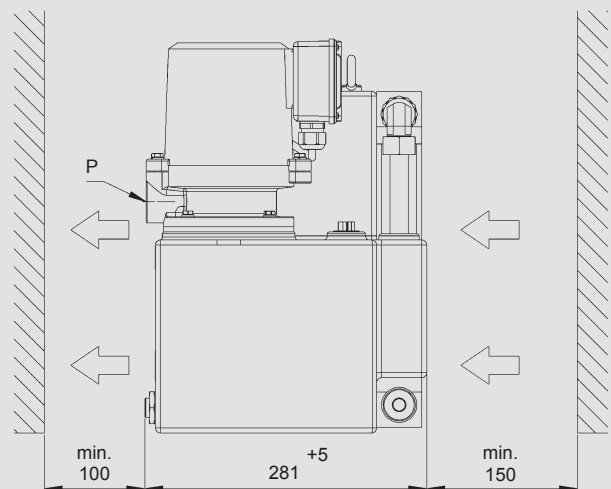
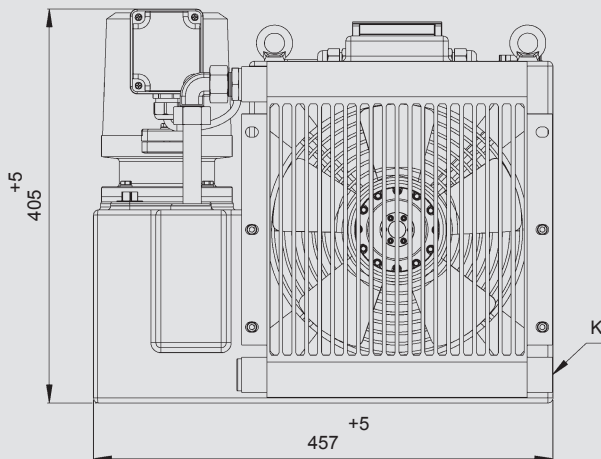
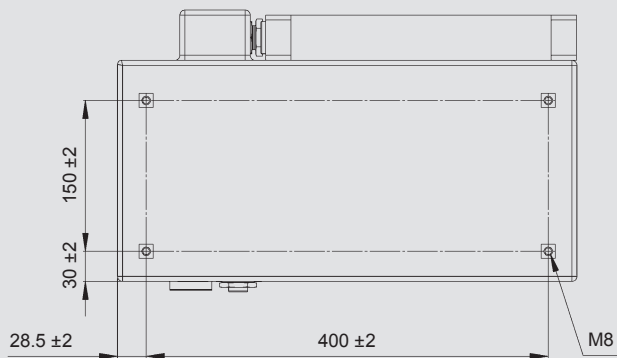

Note:

We recommend maintaining the specified minimum distance to ensure an unimpeded air inlet and air outlet. Anything below the minimum distance can affect cooling capacity and noise emissions.

Model code

FLKS - 1H - 2.0 - W - YA0 - 0 - 0

Type

FLKS = fluid/air cooling system

Size

Type code

Operating fluid

W = water-glycol (standard)

Pump

Y = version with pump TKY

A = version with pump MTA50

Other pumps on request.

Motor voltage

A = 380 – 420 V – 50 Hz / 400 – 480 V – 60 Hz, 3PH (pump TKY and MTA50)

See also “electrical data”.

Position of pump connection

0 = standard

Coating

0 = none

(FLKS-1: white plastic tank housing)

Accessories

0 = none (standard)

For corresponding accessory number, see table.

Accessories

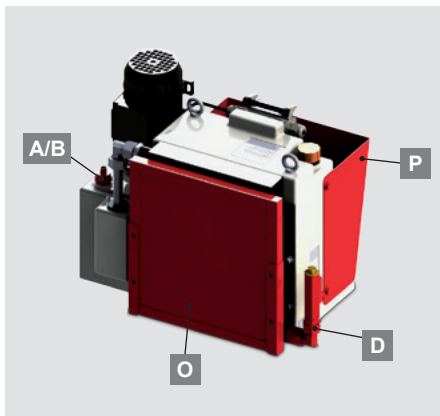

A	Fill level and 60 °C temperature switch		•										•
B	Fill level switch 2 switch points			•				•					•
D	Flow switch				•			•				•	
O	Air filter					•		•	•	•	•	•	•
P	Air duct						•	•		•			•
Accessory number		0	1	44	30	14	36	43	59	82	122	124	105

See also “Accessories for FLKS” for more information.

FLKS-1H standard

Part no.	Designation	Pump	Version
3426850	FLKS-1H/2.0/W/YA0/0/0	TKY	No accessories, fixed speed
3322575	FLKS-1H/2.0/W/AA0/0/0	MTA50	No accessories, fixed speed



Fluid/Air Cooling Systems FLKS-1H PLUS

Symbol

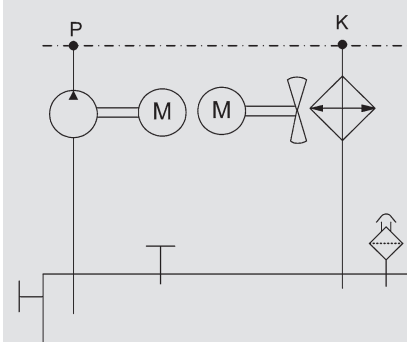

General

The **FLKS-1H PLUS** is a compact fluid/air cooling system with a plastic tank housing and integrated air duct. This lightweight and robust design makes it suitable for diverse applications.

Function

The pump conveys the operating medium from the tank through the part being cooled to the heat exchanger. The axial fan provides the necessary air flow through the heat exchanger to cool the operating medium.

Field of application

- Liquid-cooled drives: motor spindles, torque motors, servo motors, linear motors
- Inverter cooling
- Gearbox cooling and lubrication
- Bearing cooling
- Tool cooling

Technical data

Cooling capacity	Max. 0.18 kW/K (see cooling capacity diagram)
Flow rate	5 – 25 l/min (see output diagrams)
Operating fluid	Version with water glycol (W): Potable water with 35 – 40 % ethylene glycol-based or propylene glycol-based antifreeze and anti-corrosion concentration. Other fluids on request (e.g. mineral oil).
Permitted temperatures	Fluid temperature: max. +60 °C Ambient temperature: 0 °C to +45 °C
Tank volume	5.5 – 7.5 l
Weight	Max. 26 kg
Noise (acoustic pressure)	69/71 dB(A) at 50/60 Hz (at 1 m)
Hydraulic connection	Pump P (flow): G $\frac{3}{4}$ " Heat exchanger K (return): G $\frac{3}{4}$ " If possible, refrain from reducing the size of the line required for the threaded connections.
Electrical connection	The motors are usually electrically connected using a heavy-duty connector (connection via terminal box available upon request).
Mounting position	Pump vertical
Accessories	<ul style="list-style-type: none"> ● Air filter ● Air duct ● Fill level switch ● Fill level and temperature switch ● Flow switch Combinations and other accessories upon request.

Cooling capacity

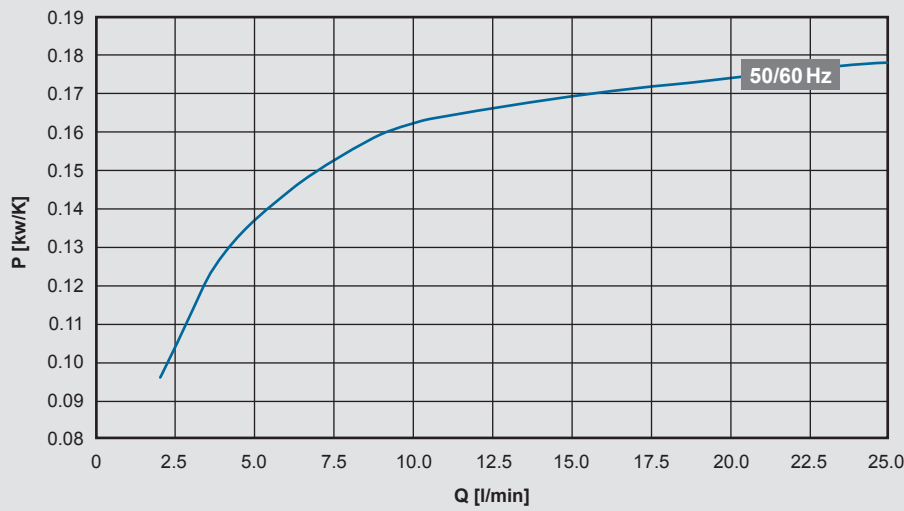

Cooling capacity tolerance: ± 5 %

The cooling capacity is calculated via the following formula:

$$P \text{ [kW]} = P_{\text{spec.}} \text{ [kW/K]} \times \text{ITD} \text{ [K]}$$

ITD (inlet temperature difference) = cooler inlet temperature of operating medium – air inlet temperature

Output data

601 pump version

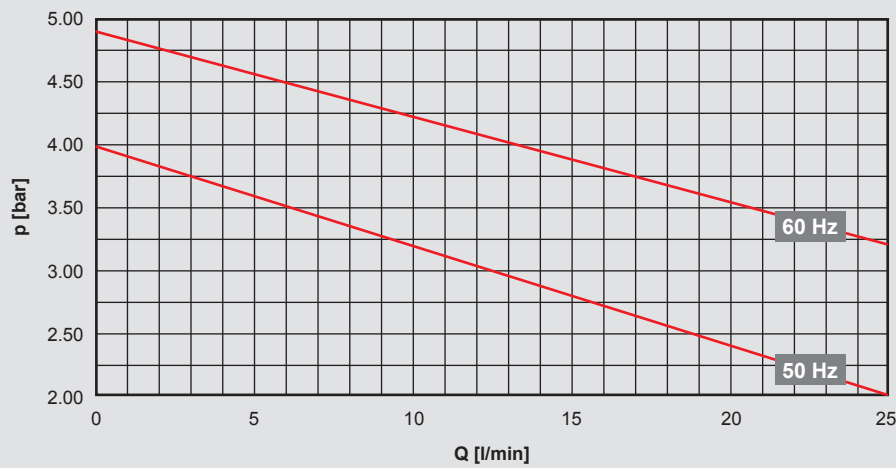

Operating range: 5 – 25 l/min

Electrical data:

Permissible voltage range:
 380 – 420 V – 50 Hz – 3 PH
 400 – 480 V – 60 Hz – 3 PH
 Voltage tolerance +5% / -10%

Motor capacity (50/60 Hz):

Pump: 0.50 / 0.70 kW
 Fan: 0.11 / 0.15 kW

Version with pump MTA50

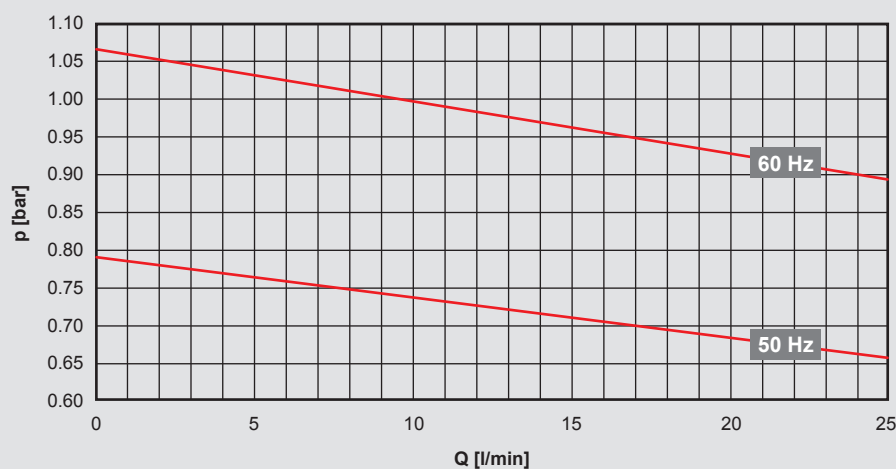

Operating range: 5 – 25 l/min

Output tolerance: ± 9%, pumping head tolerance: ± 7% as per DIN EN ISO 9906 Cl. 2, App. A

Electrical data:

Permissible voltage range:
 380 – 415 V – 50 Hz – 3 PH
 380 – 480 V – 60 Hz – 3 PH
 Voltage tolerance +5% / -10%

Motor capacity (50/60 Hz):

Pump: 0.17 / 0.27 kW
 Fan: 0.11 / 0.15 kW

Note:

The operating point of the pump (flow rate) depends on the characteristic curve (line sizes, line lengths, screwing elements). In general, the less the system losses, the greater the flow rate and the greater the cooling capacity. Please contact Technical Sales with questions on cooling capacity and output data with other operating fluids, as well as on special voltages or other pumps.

Electrical connection

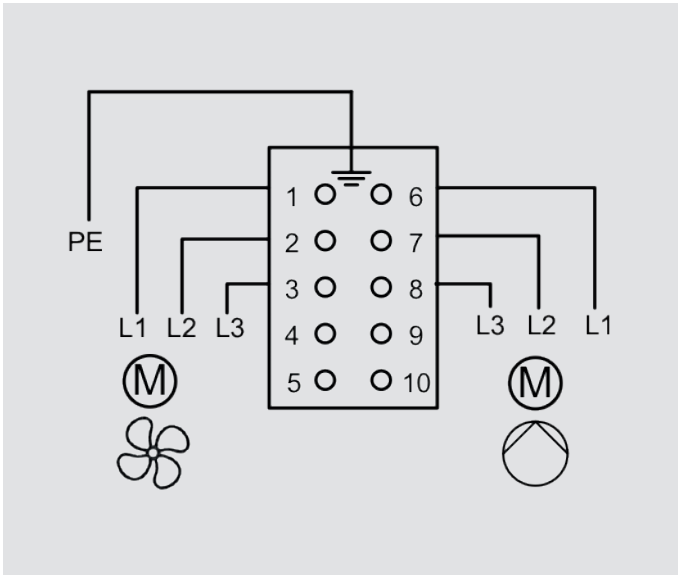

The motor is usually electrically connected using a heavy-duty connector.

E.g. Harting housing 09300101541 and insert 09330102716.

Dimensions

[mm]

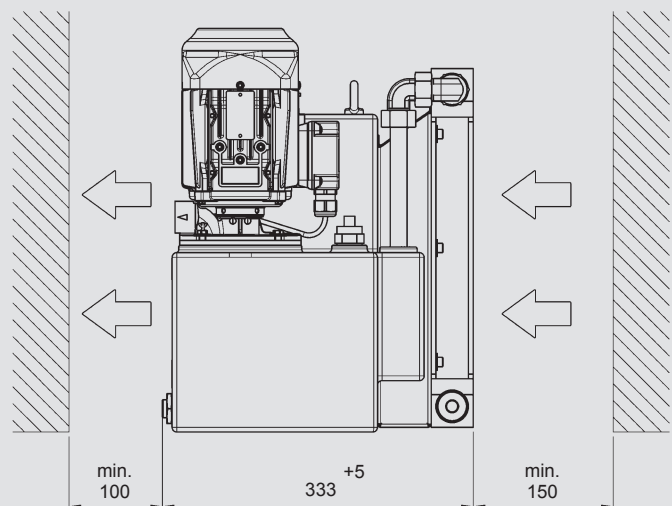
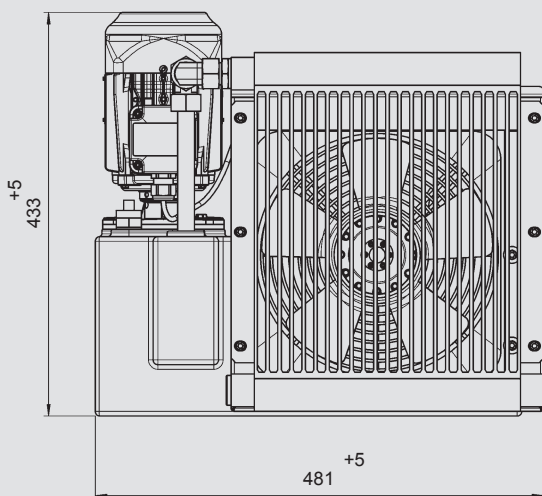
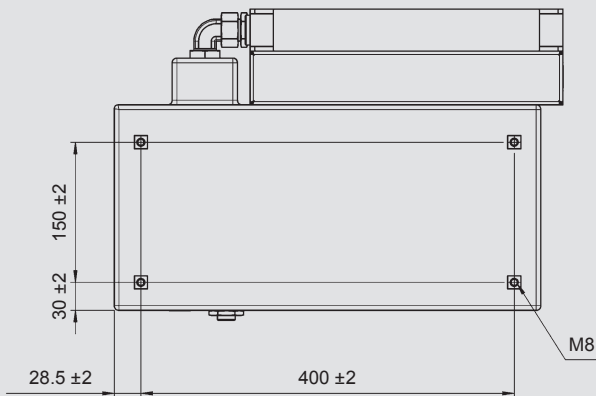

Note:

We recommend maintaining the specified minimum distance to ensure an unimpeded air inlet and air outlet. Anything below the minimum distance can affect cooling capacity and noise emissions.

Model code

FLKS - 1H PLUS - 2.4 - W - 601A2 - 0 - 0

Type

FLKS = fluid/air cooling system

Size

Type code

Operating fluid

W = water-glycol (standard)

Pump

601 = version with pump 601
 A = version with pump MTA50
 Other pumps on request.

Motor voltage

A = 380 – 420 V – 50 Hz / 400 – 480 V – 60 Hz, 3PH (pump 601 and MTA50)
 See also "electrical data".

Position of pump connection

0 = standard
 2 = rotated 180°

Coating

0 = none
 (FLKS-1: white plastic tank housing)

Accessories

0 = none (standard)
 For corresponding accessory number, see table.

Accessories

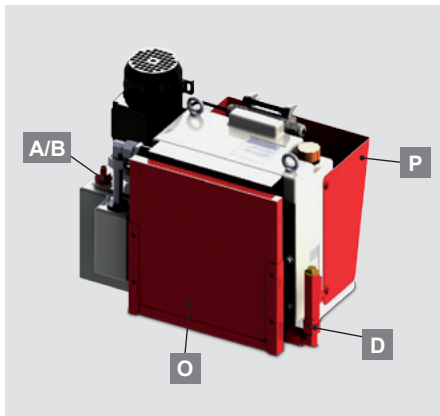

A	Fill level and 60 °C temperature switch		•									•	
B	Fill level switch 2 switch points			•				•				•	
D	Flow switch				•			•			•		
O	Air filter					•		•	•	•	•	•	
P	Air duct						•	•		•		•	
Accessory number		0	1	44	30	14	36	43	59	82	122	124	105

See also "Accessories for FLKS" for more information.

FLKS-1H PLUS standard

Part no.	Designation	Pump	Version
3924557	FLKS-1H PLUS/2.4/W/601A2/0/0	601	No accessories, fixed speed
3908279	FLKS-1H PLUS/2.0/W/AA0/0/0	MTA50	No accessories, fixed speed



Fluid/Air Cooling Systems FLKS-2S

Symbol

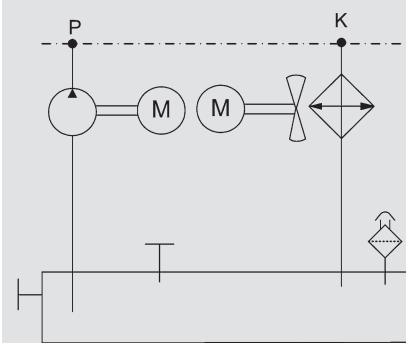

General

The **FLKS-2S** is a compact fluid/air cooling system with a plastic tank housing and integrated air duct. This lightweight and robust design makes it suitable for diverse applications.

Function

The pump conveys the operating medium from the tank through the part being cooled to the heat exchanger. The axial fan provides the necessary air flow through the heat exchanger to cool the operating medium.

Field of application

- Liquid-cooled drives: motor spindles, torque motors, servo motors, linear motors
- Inverter cooling
- Gearbox cooling and lubrication
- Bearing cooling
- Tool cooling

Technical data

Cooling capacity	Max. 0.31 kW/K (see cooling capacity diagram)
Flow rate	5 – 40 l/min (see output diagrams)
Operating fluid	Version with water glycol (W): Potable water with 35 – 40 % ethylene glycol-based or propylene glycol-based antifreeze and anti-corrosion concentration. Other fluids on request (e.g. mineral oil).
Permitted temperatures	Fluid temperature: max. +60 °C Ambient temperature: 0 °C to +45 °C
Tank volume	15.0 – 19.5 l
Weight	Max. 32 kg
Noise (acoustic pressure)	62/63 dB(A) at 50/60 Hz (at 1 m)
Hydraulic connection	Pump P (flow): G $\frac{3}{4}$ " Heat exchanger K (return): G $\frac{3}{4}$ " If possible, refrain from reducing the size of the line required for the threaded connections.
Electrical connection	The motors are usually electrically connected using a heavy-duty connector (connection via terminal box available upon request).
Mounting position	Pump vertical
Accessories	<ul style="list-style-type: none"> ● Air filter ● Air duct ● Fill level switch ● Fill level and temperature switch ● Flow switch Combinations and other accessories upon request.

Cooling capacity

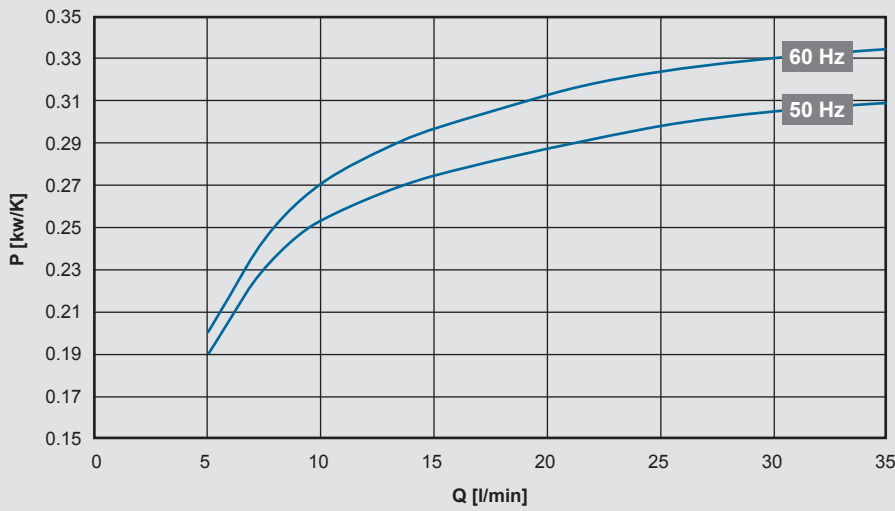

Cooling capacity tolerance: $\pm 5\%$

The cooling capacity is calculated via the following formula:

$$P [\text{kW}] = P_{\text{spec.}} [\text{kW/K}] \times \text{ITD} [\text{K}]$$

ITD (inlet temperature difference) = cooler inlet temperature of operating medium – air inlet temperature

Output data

601 pump version

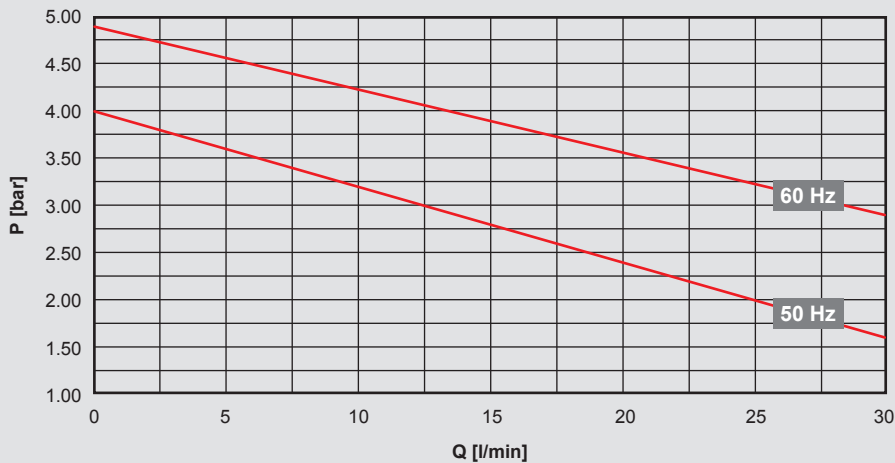

Operating range: 5 – 30 l/min

Electrical data:

Permissible voltage range:
 380 – 420 V – 50 Hz – 3 PH
 400 – 480 V – 60 Hz – 3 PH
 Voltage tolerance +5% / -10%

Motor capacity (50/60 Hz):

Pump: 0.50 / 0.70 kW
 Fan: 0.11 / 0.145 kW

MTH2-4 pump version

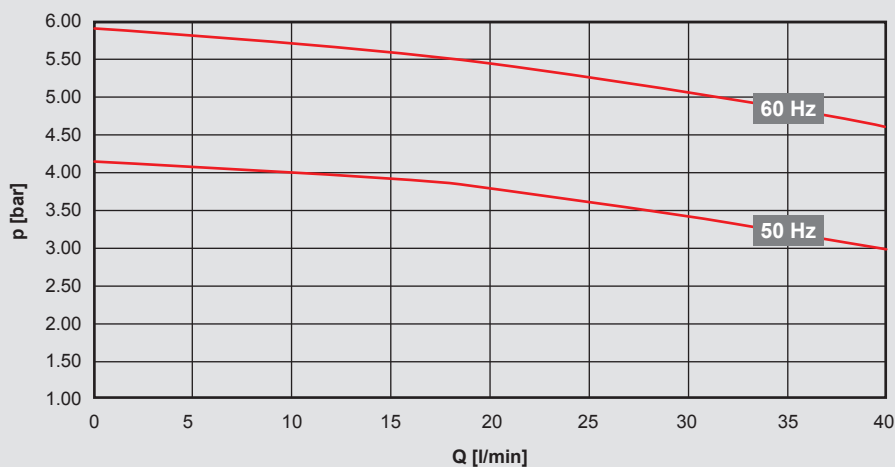

Operating range: 10 – 40 l/min

Output tolerance: $\pm 9\%$, pumping head tolerance: $\pm 7\%$ as per DIN EN ISO 9906 Cl. 2, App. A

Electrical data:

Permissible voltage range:
 380 – 415 V – 50 Hz – 3 PH
 380 – 440 V – 60 Hz – 3 PH
 Voltage tolerance +5% / -10%

Motor capacity (50/60 Hz):

Pump: 0.62 / 0.90 kW
 Fan: 0.11 / 0.145 kW

Note:

The operating point of the pump (flow rate) depends on the characteristic curve (line sizes, line lengths, screwing elements). In general, the less the system losses, the greater the flow rate and the greater the cooling capacity.

Please contact Technical Sales with questions on cooling capacity and output data with other operating fluids, as well as on special voltages or other pumps.

Electrical connection

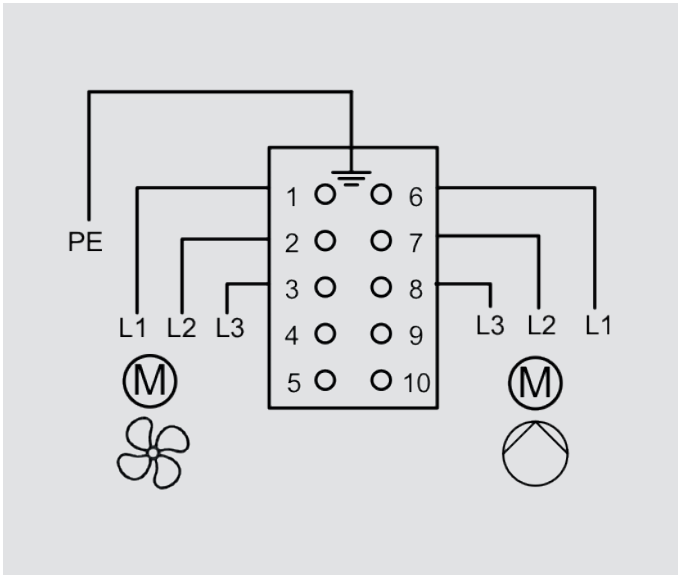

The motor is usually electrically connected using a heavy-duty connector.

E.g. Harting housing 09300101541 and insert 09330102716.

Dimensions

[mm]

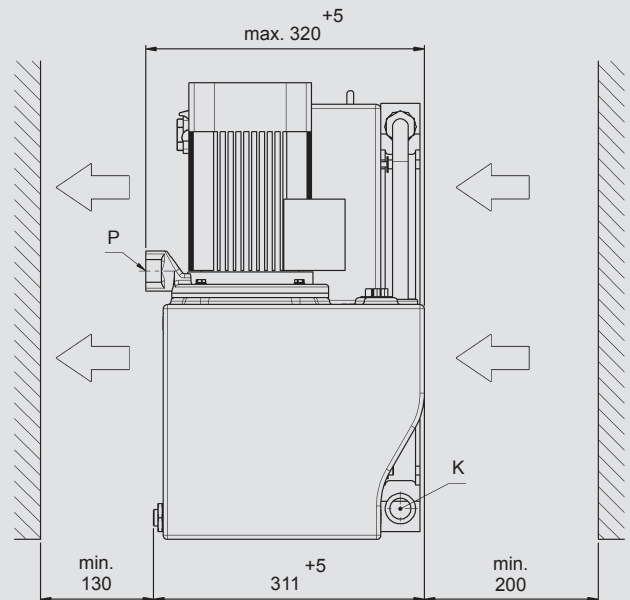
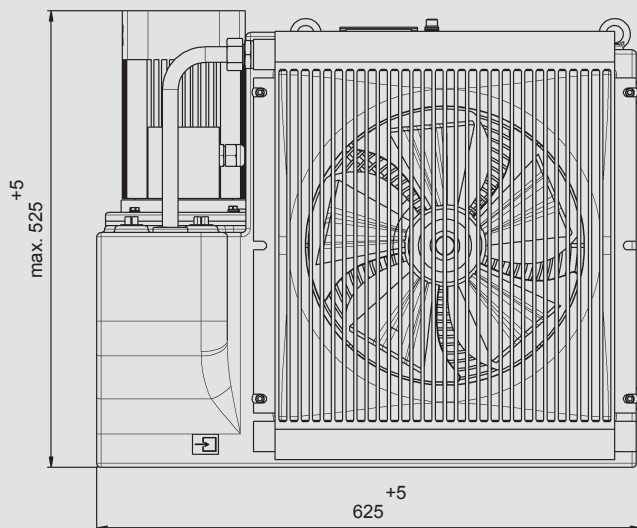
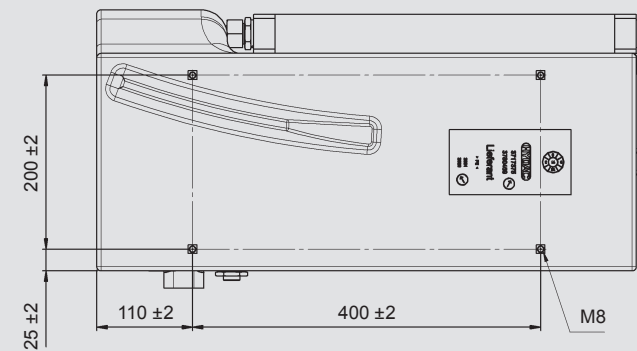

Note:

We recommend maintaining the specified minimum distance to ensure an unimpeded air inlet and air outlet. Anything below the minimum distance can affect cooling capacity and noise emissions.

Model code

FLKS - 2S - 1.0 - W - 601A0 - 0 - 0

Type

FLKS = fluid/air cooling system

Size

Type code

Operating fluid

W = water-glycol (standard)

Pump

601 = version with pump 601
 H2-4 = version with pump MTH2-4
 Other pumps on request.

Motor voltage

A = 380 – 420 V – 50 Hz / 400 – 480 V – 60 Hz, 3PH (pump 601)
 B = 380 – 415 V – 50 Hz / 380 – 440 V – 60 Hz, 3PH (pump MTH2-4)
 See also "electrical data".

Position of pump connection

0 = standard

Coating

0 = none
 (FLKS-2: white plastic tank housing)

Accessories

0 = none (standard)
 For corresponding accessory number, see table.

Accessories

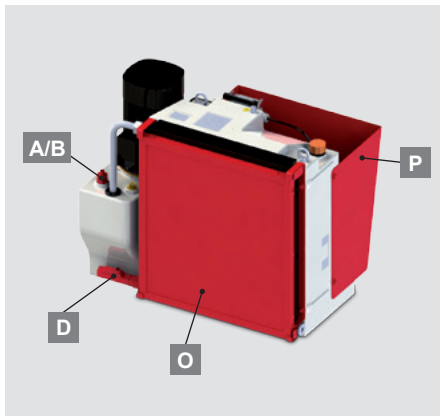

A	Fill level and 60 °C temperature switch		•									•	
B	Fill level switch 2 switch points			•				•				•	
D	Flow switch				•			•			•		
O	Air filter					•		•	•	•	•	•	
P	Air duct						•	•		•		•	
Accessory number		0	1	44	30	14	36	43	59	82	122	124	105

See also "Accessories for FLKS" for more information.

FLKS-2S standard

Part no.	Designation	Pump	Version
3811499	FLKS-2S/1.0/W/601A0/0/0	601	No accessories, fixed speed
3905239	FLKS-2S/1.0/W/H2-4B0/0/0	MTH2-4	No accessories, fixed speed



Fluid/Air Cooling Systems FLKS-2EC with speed control

Symbol

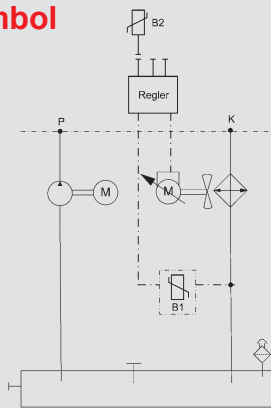

Technical data

Cooling capacity	Max. 0.33 kW/K (see cooling capacity diagram)
Flow rate	5 – 40 l/min (see output diagrams)
Operating fluid	Version with water glycol (W): Potable water with 35 – 40 % ethylene glycol-based or propylene glycol-based antifreeze and anti-corrosion concentration. Other fluids on request (e.g. mineral oil).
Permitted temperatures	Fluid temperature: max. +60 °C Ambient temperature: 0 °C to +45 °C
Tank volume	15.0 – 19.5 l
Weight	Max. 33 kg
Noise (acoustic pressure)	< 64 dB(A) at 50/60 Hz (at 1 m)
Hydraulic connection	Pump P (flow): G $\frac{3}{4}$ " Heat exchanger K (return): G $\frac{3}{4}$ " If possible, refrain from reducing the size of the line required for the threaded connections.
Electrical connection	The motors are usually electrically connected using a heavy-duty connector.
Mounting position	Pump vertical
Accessories	<ul style="list-style-type: none"> ● Air filter ● Air duct ● Fill level switch ● Fill level and temperature switch ● Flow switch Combinations and other accessories upon request.

General

The **FLKS-2EC** is a compact fluid / air cooling system with a plastic tank housing, integrated air duct, pump and variable-speed fan.

This lightweight and robust design makes it suitable for diverse applications.

Function

The pump conveys the operating medium from the tank through the part being cooled to the heat exchanger. The axial fan provides the necessary air flow through the heat exchanger to cool the operating medium. The speed can vary depending on the application.

Field of application

- Liquid-cooled drives: motor spindles, torque motors, servo motors, linear motors
- Inverter cooling
- Gearbox cooling and lubrication
- Bearing cooling
- Tool cooling

Speed control

The temperature sensor of the **FLKS-2EC5** measures the water-glycol outlet temperature from the cooling system. The sensor's 0 – 10 V analogue signal is assigned a temperature range of 25 – 45 °C. The signal is forwarded to the EC fan according to the measured fluid outlet temperature to control the speed. The fan switches on at 1.5 V (= 28 °C) and reaches its maximum speed at 10 V (= 45 °C).

Even at low ambient temperatures, the fluid temperature cannot drop below 28 °C given constant power input. This prevents condensation on electrical components.

Application:

Specially suited for low air temperatures, e.g. outdoors.



Speed control

The **FLKS-2EC3** also comes with a PID controller (closed loop). The temperature sensor measures the fluid outlet temperature (variable). This temperature is continuously compared with the reference value (ambient temperature + set differential $D \Delta T$). The PID controller continually adjusts the speed of the fan, in order to align the fluid temperature with the ambient temperature.

The outlet temperature remains at a set differential above the ambient temperature regardless of the input temperature of the fluid (performance of the machine).

Application:

Particularly for precision cooling (e.g. in machine tools).

Lower fan speed

- = lower sound level
- = lower power consumption
- = lower contamination

Cooling capacity

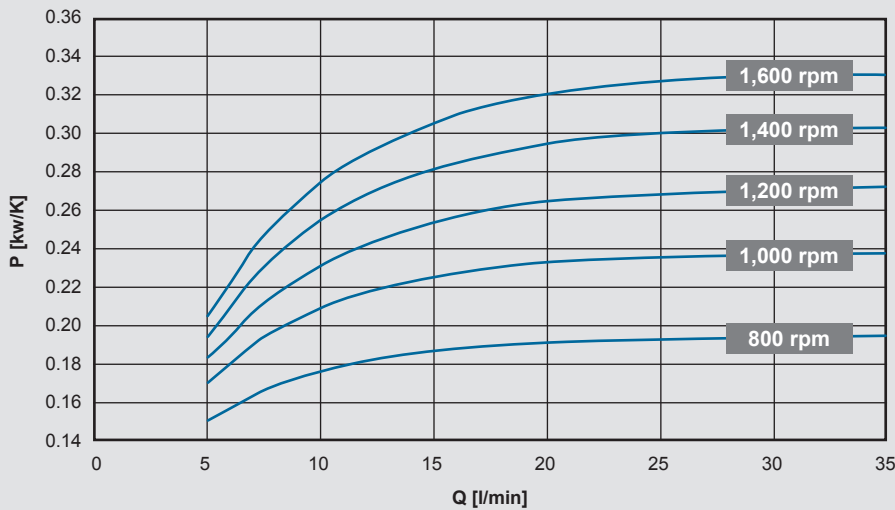

Cooling capacity tolerance: ± 5 %

The cooling capacity is calculated via the following formula:

$$P \text{ [kW]} = P_{\text{spec.}} \text{ [kW/K]} \times \text{ITD} \text{ [K]}$$

ITD (inlet temperature difference) = cooler inlet temperature of operating medium – air inlet temperature

Output data

601 pump version

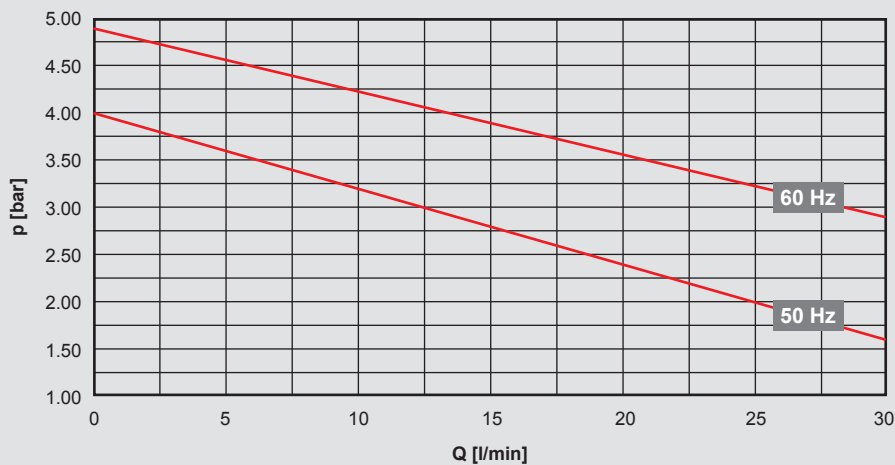

Operating range: 5 – 30 l/min

Electrical data:

Permitted voltage range:

Pump:

380 – 420 V – 50 Hz – 3 PH
400 – 480 V – 60 Hz – 3 PH
Voltage tolerance +5% / -10%

Fan:

200 – 240 V – 50/60 Hz – 1 PH
Voltage tolerance ± 10%

Motor capacity (50/60 Hz):

Pump: 0.50 / 0.70 kW
Fan: 0.14 kW

MTH2-4 pump version

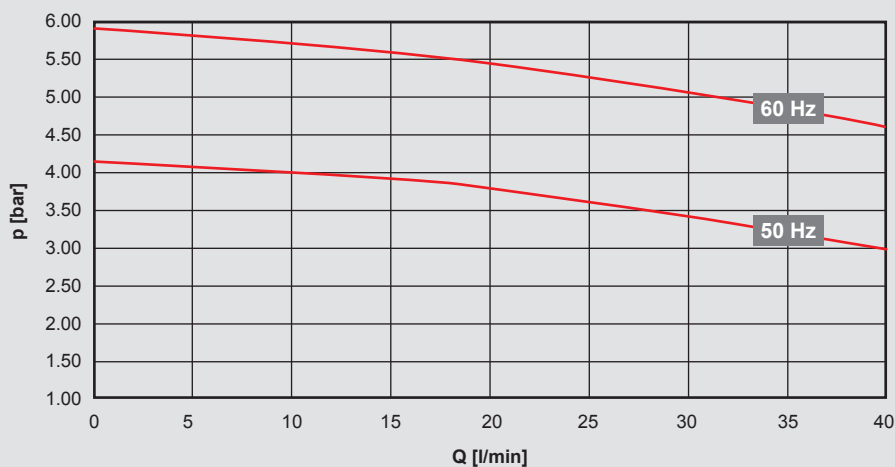

Operating range: 10 – 40 l/min

Output tolerance: ± 9%, pumping head tolerance: ± 7% as per DIN EN ISO 9906 Cl. 2, App. A

Electrical data:

Permitted voltage range:

Pump:

380 – 415 V – 50 Hz – 3 PH
380 – 440 V – 60 Hz – 3 PH
Voltage tolerance +5% / -10%

Fan:

200 – 240 V – 50/60 Hz – 1 PH
Voltage tolerance ± 10%

Motor capacity (50/60 Hz):

Pump: 0.62 / 0.90 kW
Fan: 0.14 kW

Note:

The operating point of the pump (flow rate) depends on the characteristic curve (line sizes, line lengths, screwing elements). In general, the less the system losses, the greater the flow rate and the greater the cooling capacity. Please contact Technical Sales with questions on cooling capacity and output data with other operating fluids, as well as on special voltages or other pumps.

Electrical connection

The motor is usually electrically connected using a heavy-duty connector.

Additional 24 V DC control voltage, more information available upon request.

Dimensions

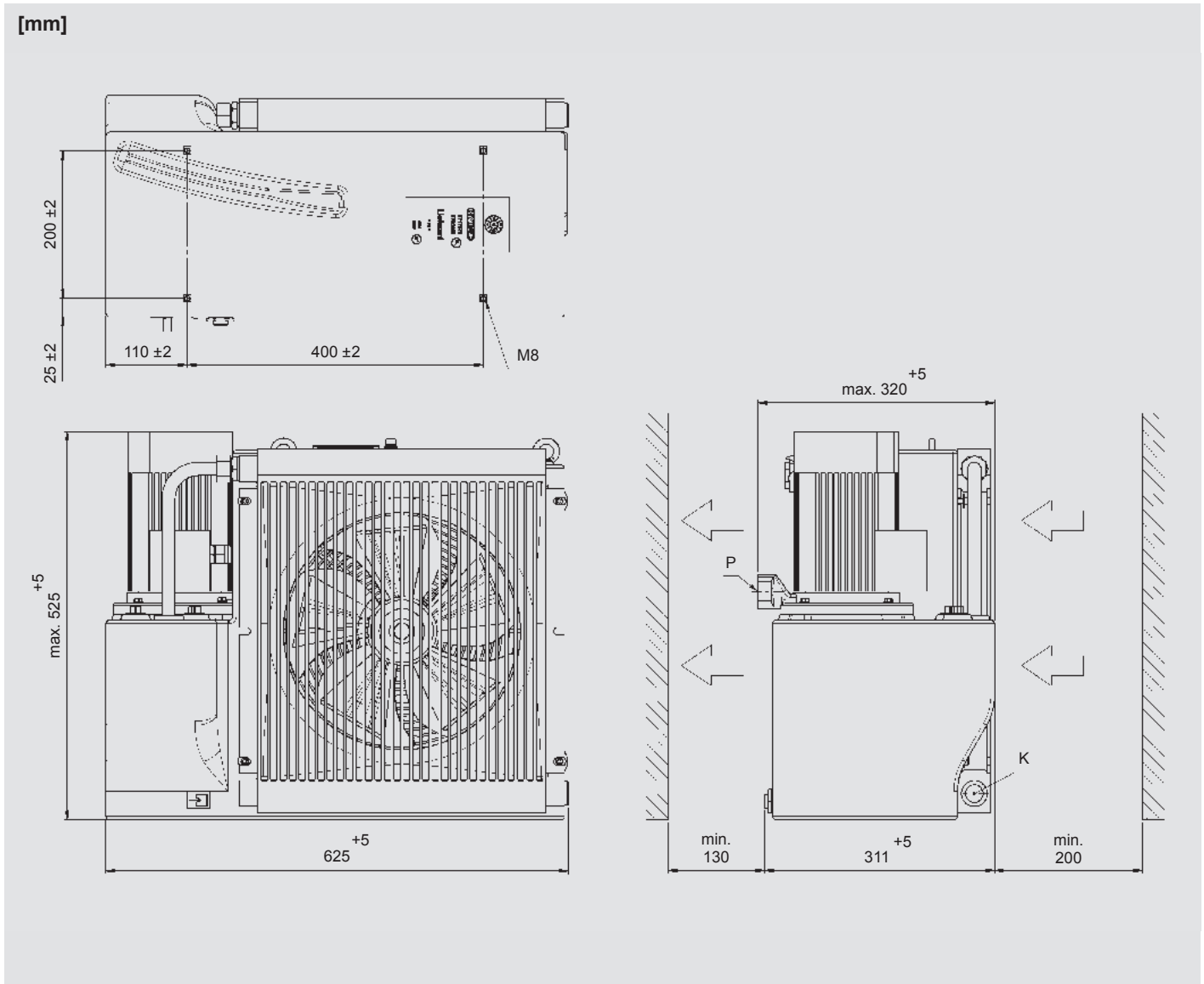

Note:

We recommend maintaining the specified minimum distance to ensure an unimpeded air inlet and air outlet. Anything below the minimum distance can affect cooling capacity and noise emissions.

Model code

FLKS - 2 - EC3 - 1.0 - W - 601A0 - 0 - 0

Type

FLKS = fluid/air cooling system

Size

Speed control (open-loop/closed-loop)

EC3 = speed control, closed-loop (with PID controller)

EC5 = speed control, open-loop (with temperature sensor)

Type code

Operating fluid

W = water-glycol (standard)

Pump

601 = version with pump 601

H2-4 = version with pump MTH2-4

Other pumps on request.

Motor voltage

A = 380 – 420 V – 50 Hz / 400 – 480 V – 60 Hz, 3PH (pump 601)
200 – 240 V – 50/60 Hz, 1PH (fan)

B = 380 – 415 V – 50 Hz / 380 – 440 V – 60 Hz, 3PH (pump MTH2-4)
200 – 240 V – 50/60 Hz, 1PH (fan)

See electrical data.

Position of pump connection

0 = standard

Coating

0 = none

(FLKS-2: white plastic tank housing)

Accessories

0 = none (standard)

For corresponding accessory number, see table.



Fluid/Air Cooling Systems FLKS-3S

Symbol

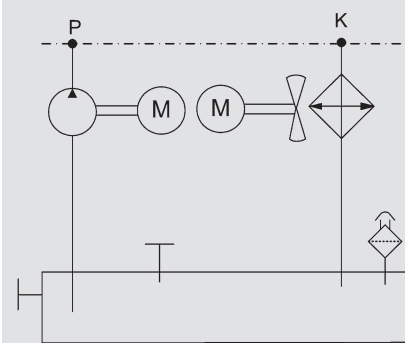

General

The **FLKS-3S** is a compact fluid/air cooling system with a plastic tank housing and integrated air duct. This lightweight and robust design makes it suitable for diverse applications.

Function

The pump conveys the operating medium from the tank through the part being cooled to the heat exchanger. The axial fan provides the necessary air flow through the heat exchanger to cool the operating medium.

Field of application

- Liquid-cooled drives: motor spindles, torque motors, servo motors, linear motors
- Inverter cooling
- Gearbox cooling and lubrication
- Bearing cooling
- Tool cooling

Technical data

Cooling capacity	Max. 0.46 kW/K (see cooling capacity diagram)
Flow rate	5 – 40 l/min (see output diagrams)
Operating fluid	Version with water glycol (W): Potable water with 35 – 40 % ethylene glycol-based or propylene glycol-based antifreeze and anti-corrosion concentration. Other fluids on request (e.g. mineral oil).
Permitted temperatures	Fluid temperature: max. +60 °C Ambient temperature: 0 °C to +45 °C
Tank volume	20.0 – 28.5 l
Weight	Max. 45 kg
Noise (acoustic pressure)	64/67 dB(A) at 50/60 Hz (at 1 m)
Hydraulic connection	Pump P (flow): G $\frac{3}{4}$ " Heat exchanger K (return): G $\frac{3}{4}$ " If possible, refrain from reducing the size of the line required for the threaded connections.
Electrical connection	The motors are usually electrically connected using a heavy-duty connector (connection via terminal box available upon request).
Mounting position	Pump vertical
Accessories	<ul style="list-style-type: none"> ● Air filter ● Air duct ● Fill level switch ● Fill level and temperature switch ● Flow switch Combinations and other accessories upon request.

Cooling capacity

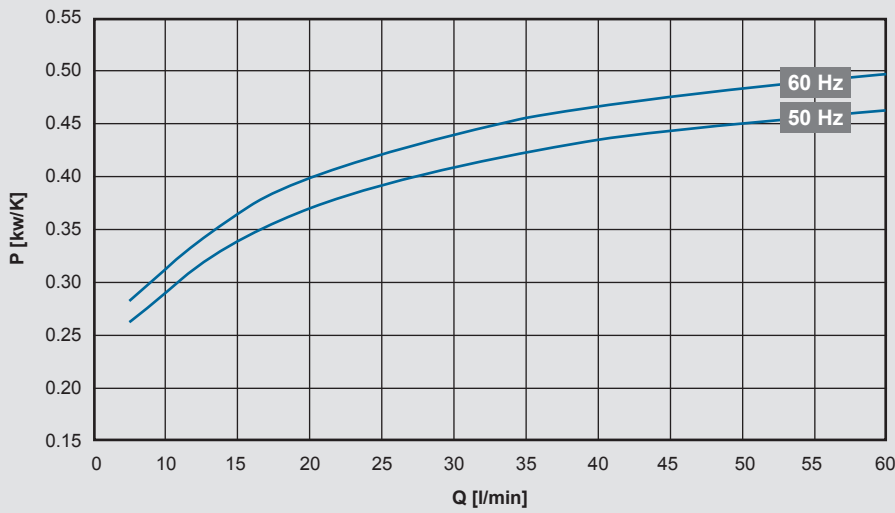

Cooling capacity tolerance: ± 5 %

The cooling capacity is calculated via the following formula:

$$P \text{ [kW]} = P_{\text{spec.}} \text{ [kW/K]} \times \text{ITD [K]}$$

ITD (inlet temperature difference) = cooler inlet temperature of operating medium – air inlet temperature

Output data

601 pump version

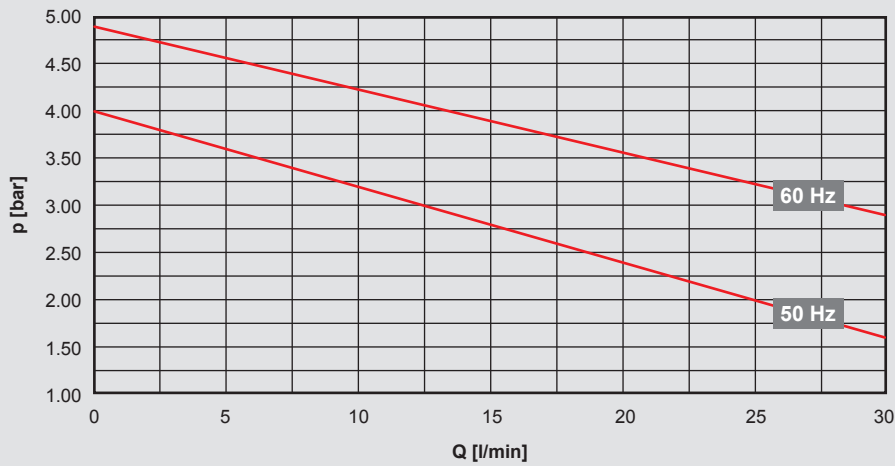

Operating range: 5 – 30 l/min

Electrical data:

Permissible voltage range:
 380 – 420 V – 50 Hz – 3 PH
 400 – 480 V – 60 Hz – 3 PH
 Voltage tolerance +5% / -10%

Motor capacity (50/60 Hz):

Pump: 0.50 / 0.70 kW
 Fan: 0.17 / 0.23 kW

MTH2-4 pump version

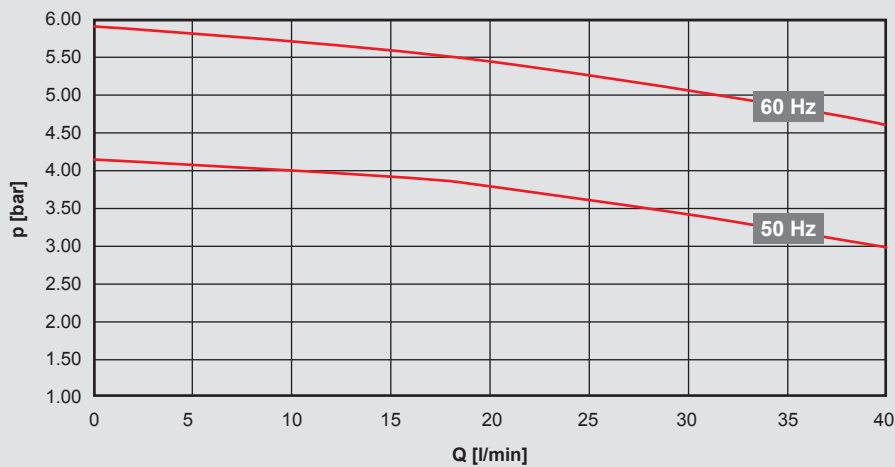

Operating range: 10 – 40 l/min

Output tolerance: ±9%, pumping head tolerance: ±7% as per DIN EN ISO 9906 Cl. 2, App. A

Electrical data:

Permissible voltage range:
 380 – 415 V – 50 Hz – 3 PH
 380 – 440 V – 60 Hz – 3 PH
 Voltage tolerance +5% / -10%

Motor capacity (50/60 Hz):

Pump: 0.62 / 0.90 kW
 Fan: 0.17 / 0.23 kW

Note:

The operating point of the pump (flow rate) depends on the characteristic curve (line sizes, line lengths, screwing elements). In general, the less the system losses, the greater the flow rate and the greater the cooling capacity.

Please contact Technical Sales with questions on cooling capacity and output data with other operating fluids, as well as on special voltages or other pumps.

Electrical connection

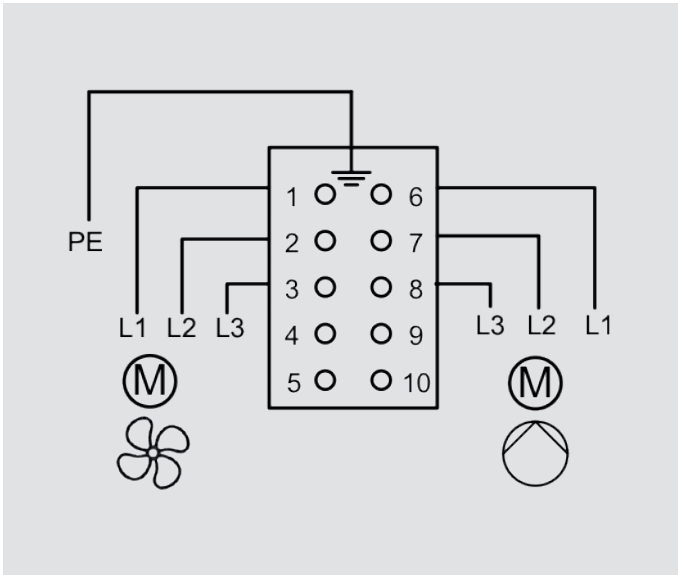

The motor is usually electrically connected using a heavy-duty connector.

E.g. Harting housing 09300101541 and insert 09330102716.

Dimensions

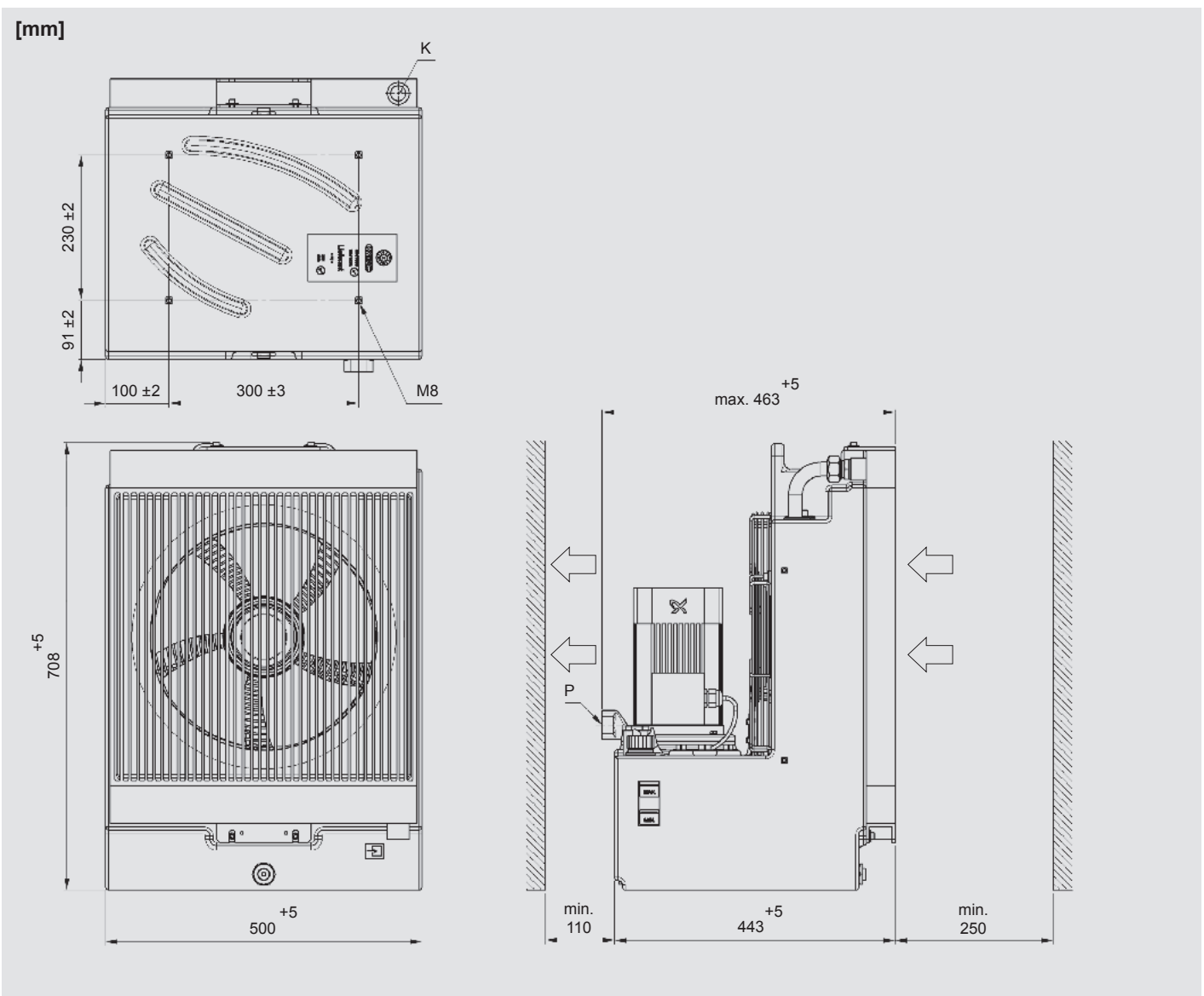

Note:

We recommend maintaining the specified minimum distance to ensure an unimpeded air inlet and air outlet. Anything below the minimum distance can affect cooling capacity and noise emissions.

Model code

FLKS - 3S - 3.0 - W - 601A0 - 0 - 0

Type

FLKS = fluid/air cooling system

Size

Type code

Operating medium

W = water-glycol (standard)

Pump

601 = version with pump 601
 H2-4 = version with pump MTH2-4
 Other pumps on request.

Motor voltage

A = 380 – 420 V – 50 Hz / 400 – 480 V – 60 Hz, 3PH (pump 601)
 B = 380 – 415 V – 50 Hz / 380 – 440 V – 60 Hz, 3PH (pump MTH2-4)
 See also "electrical data".

Position of pump connection

0 = standard

Coating

0 = none
 (FLKS-3: white plastic tank housing)

Accessories

0 = none (standard)
 For corresponding accessory number, see table.

Accessories

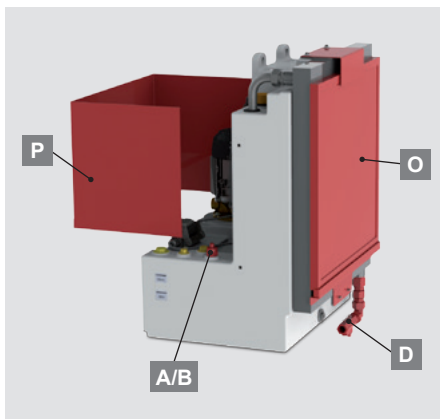

A	Fill level and 60 °C temperature switch		•									•	
B	Fill level switch 2 switch points			•			•				•		
D	Flow switch			•		•			•				
O	Air filter				•	•	•	•	•	•	•	•	
P	Air duct					•	•	•			•		
Accessory number		0	1	44	30	14	36	43	59	82	122	124	105

See also "Accessories for FLKS" for more information.

FLKS-3S standard

Part no.	Designation	Pump	Version
3991017	FLKS-3S/3.0/W/601A0/0/0	601	No accessories, fixed speed
3991211	FLKS-3S/3.0/W/H2-4B0/0/0	MTH2-4	No accessories, fixed speed



Fluid/Air Cooling Systems FLKS-3EC with speed control

Symbol

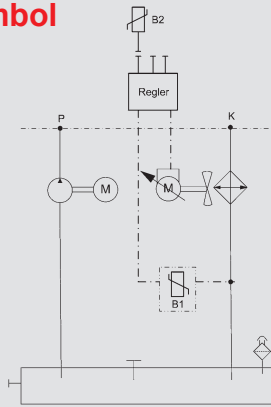

Technical data

Cooling capacity	Max. 0.50 kW/K (see cooling capacity diagram)
Flow rate	5 – 40 l/min (see output diagrams)
Operating fluid	Version with water glycol (W): Potable water with 35 – 40 % ethylene glycol-based or propylene glycol-based antifreeze and anti-corrosion concentration. Other fluids on request (e.g. mineral oil).
Permitted temperatures	Fluid temperature: max. +60 °C Ambient temperature: 0 °C to +45 °C
Tank volume	20.0 – 28.5 l
Weight	Max. 45 kg
Noise (acoustic pressure)	< 67 dB(A) at 50/60 Hz (at 1 m)
Hydraulic connection	Pump P (flow): G $\frac{3}{4}$ " Heat exchanger K (return): G $\frac{3}{4}$ " If possible, refrain from reducing the size of the line required for the threaded connections.
Electrical connection	The motors are usually electrically connected using a heavy-duty connector.
Mounting position	Pump vertical
Accessories	<ul style="list-style-type: none"> ● Air filter ● Air duct ● Fill level switch ● Fill level and temperature switch ● Flow switch Combinations and other accessories upon request.

General

The **FLKS-3EC** is a compact fluid / air cooling system with a plastic tank housing, integrated air duct, pump and variable-speed fan.

This lightweight and robust design makes it suitable for diverse applications.

Function

The pump conveys the operating medium from the tank through the part being cooled to the heat exchanger. The axial fan provides the necessary air flow through the heat exchanger to cool the operating medium. The speed can vary depending on the application.

Field of application

- Liquid-cooled drives: motor spindles, torque motors, servo motors, linear motors
- Inverter cooling
- Gearbox cooling and lubrication
- Bearing cooling
- Tool cooling

Speed control

The temperature sensor of the **FLKS-3EC5** measures the water-glycol outlet temperature from the cooling system. The sensor's 0 – 10 V analogue signal is assigned a temperature range of 25 – 45 °C. The signal is forwarded to the EC fan according to the measured fluid outlet temperature to control the speed. The fan switches on at 1.5 V (= 28 °C) and reaches its maximum speed at 10 V (= 45 °C).

Even at low ambient temperatures, the fluid temperature cannot drop below 28 °C given constant power input. This prevents condensation on electrical components.

Application:

Specially suited for low air temperatures, e.g. outdoors.



Speed control

The **FLKS-3EC3** also comes with a PID controller (closed loop). The temperature sensor measures the fluid outlet temperature (variable). This temperature is continuously compared with the reference value (ambient temperature + set differential $D \Delta T$). The PID controller continually adjusts the speed of the fan, in order to align the fluid temperature with the ambient temperature.

The outlet temperature remains at a set differential above the ambient temperature regardless of the input temperature of the fluid (performance of the machine).

Application:

Particularly for precision cooling (e.g. in machine tools).

Lower fan speed

- = lower sound level
- = lower power consumption
- = lower contamination

Cooling capacity

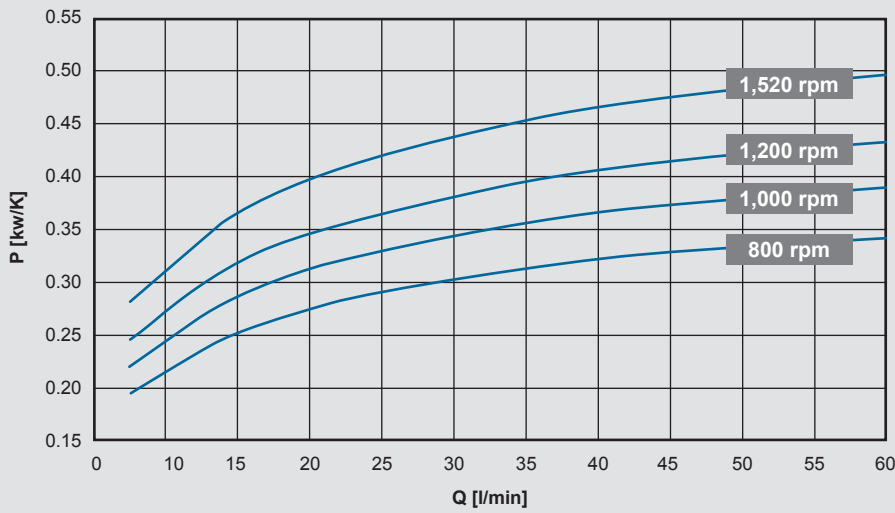

Cooling capacity tolerance: ± 5 %

The cooling capacity is calculated via the following formula:

$$P [\text{kW}] = P_{\text{spec.}} [\text{kW/K}] \times \text{ITD} [\text{K}]$$

ITD (inlet temperature difference) = cooler inlet temperature of operating medium – air inlet temperature

Output data

601 pump version

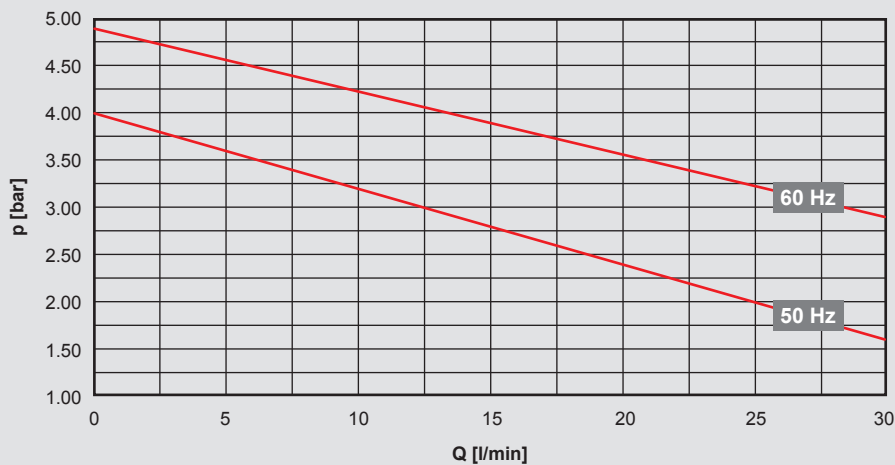

Operating range: 5 – 30 l/min

Electrical data:

Permitted voltage range:

Pump:

380 – 420 V – 50 Hz – 3 PH
400 – 480 V – 60 Hz – 3 PH
Voltage tolerance +5% / -10%

Fan:

200 – 240 V – 50/60 Hz – 1 PH
Voltage tolerance ± 10%

Motor capacity (50/60 Hz):

Pump: 0.50 / 0.70 kW
Fan: 0.165 kW

MTH2-4 pump version

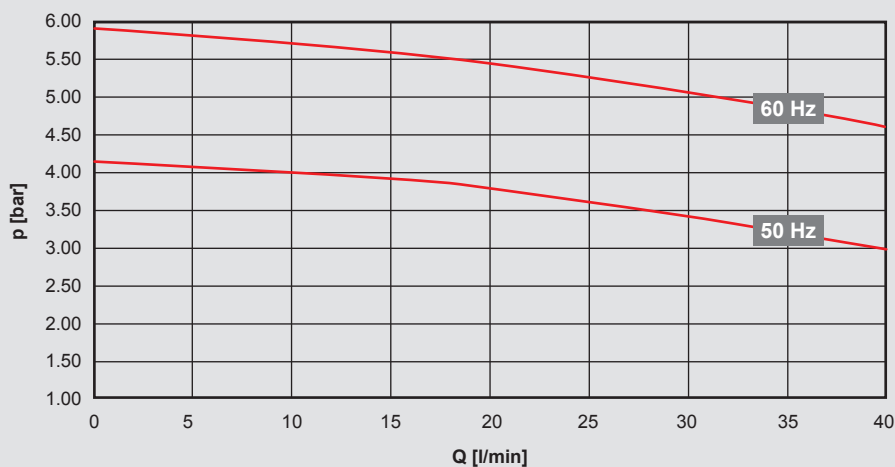

Operating range: 10 – 40 l/min

Output tolerance: ± 9%, pumping head tolerance: ± 7% as per DIN EN ISO 9906 Cl. 2, App. A

Electrical data:

Permitted voltage range:

Pump:

380 – 415 V – 50 Hz – 3 PH
380 – 440 V – 60 Hz – 3 PH
Voltage tolerance +5% / -10%

Fan:

200 – 240 V – 50/60 Hz – 1 PH
Voltage tolerance ± 10%

Motor capacity (50/60 Hz):

Pump: 0.62 / 0.90 kW
Fan: 0.165 kW

Note:

The operating point of the pump (flow rate) depends on the characteristic curve (line sizes, line lengths, screwing elements). In general, the less the system losses, the greater the flow rate and the greater the cooling capacity. Please contact Technical Sales with questions on cooling capacity and output data with other operating fluids, as well as on special voltages or other pumps.

Electrical connection

The motor is usually electrically connected using a heavy-duty connector.

Additional 24 V DC control voltage, more information available upon request.

Dimensions

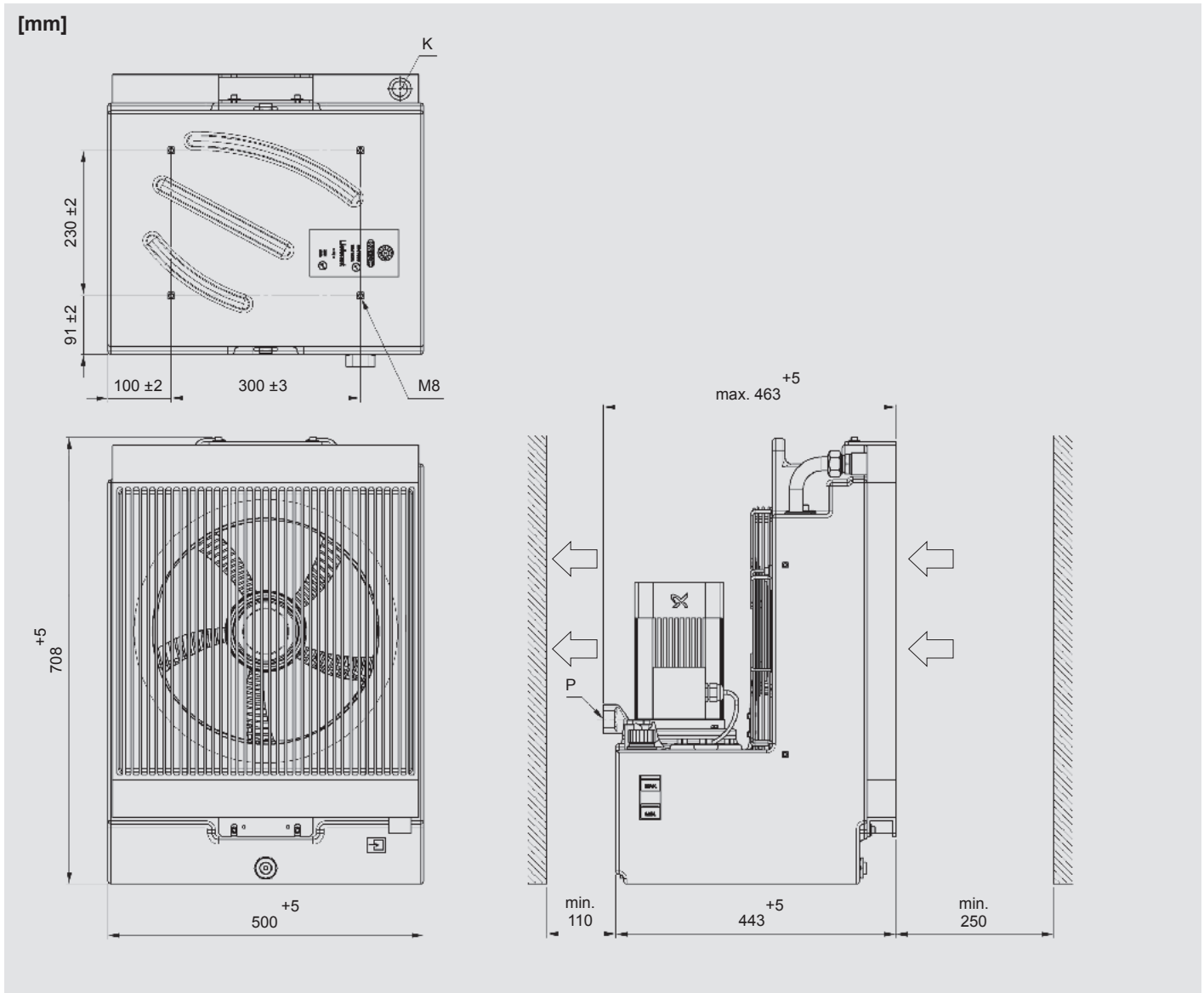

Note:

We recommend maintaining the specified minimum distance to ensure an unimpeded air inlet and air outlet. Anything below the minimum distance can affect cooling capacity and noise emissions.

Model code

FLKS - 3 - EC3 - 3.0 - W - 601A0 - 0 - 0

Type

FLKS = fluid/air cooling system

Size

Speed control (open-loop/closed-loop)

EC3 = speed control, closed-loop (with PID controller)

EC5 = speed control, open-loop (with temperature sensor)

Type code

Operating fluid

W = water-glycol (standard)

Pump

601 = version with pump 601

H2-4 = version with pump MTH2-4

Other pumps on request.

Motor voltage

A = 380 – 420 V – 50 Hz / 400 – 480 V – 60 Hz, 3PH (pump 601)
200 – 240 V – 50/60 Hz, 1PH (fan)

B = 380 – 415 V – 50 Hz / 380 – 440 V – 60 Hz, 3PH (pump MTH2-4)
200 – 240 V – 50/60 Hz, 1PH (fan)

See also electrical data.

Position of pump connection

0 = standard

Coating

0 = none

(FLKS-3: white plastic tank housing)

Accessories

0 = none (standard)

For corresponding accessory number, see table.



Fluid/Air Cooling Systems FLKS-4S

Symbol

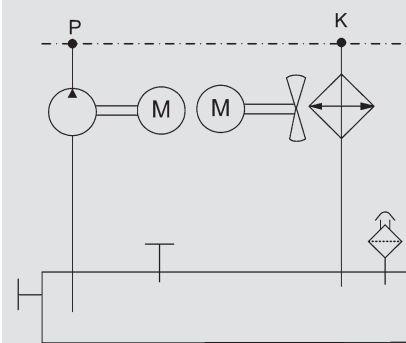

Technical data

Cooling capacity	Max. 0.65 kW/K (see cooling capacity diagram)
Flow rate	5 – 55 l/min (see output diagrams)
Operating fluid	Version with water glycol (W): Potable water with 35 – 40 % ethylene glycol-based or propylene glycol-based antifreeze and anti-corrosion concentration. Other fluids on request (e.g. mineral oil).
Permitted temperatures	Fluid temperature: max. +60 °C Ambient temperature: 0 °C to +45 °C
Tank volume	31.0 – 43.0 l
Weight	Max. 49 kg
Noise (acoustic pressure)	69/72 dB(A) at 50/60 Hz (at 1 m)
Hydraulic connection	Pump P (flow): G $\frac{3}{4}$ " Heat exchanger K (return): G $\frac{3}{4}$ " If possible, refrain from reducing the size of the line required for the threaded connections.
Electrical connection	The motors are usually electrically connected using a heavy-duty connector (connection via terminal box available upon request).
Mounting position	Pump vertical
Accessories	<ul style="list-style-type: none"> ● Air filter ● Air duct ● Fill level switch ● Fill level and temperature switch ● Flow switch Combinations and other accessories upon request.

General

The **FLKS-4S** is a compact fluid/air cooling system with a plastic tank housing and integrated air duct. This lightweight and robust design makes it suitable for diverse applications.

Function

The pump conveys the operating medium from the tank through the part being cooled to the heat exchanger. The axial fan provides the necessary air flow through the heat exchanger to cool the operating medium.

Field of application

- Liquid-cooled drives:
motor spindles, torque motors,
servo motors, linear motors
- Inverter cooling
- Gearbox cooling and lubrication
- Bearing cooling
- Tool cooling

Cooling capacity

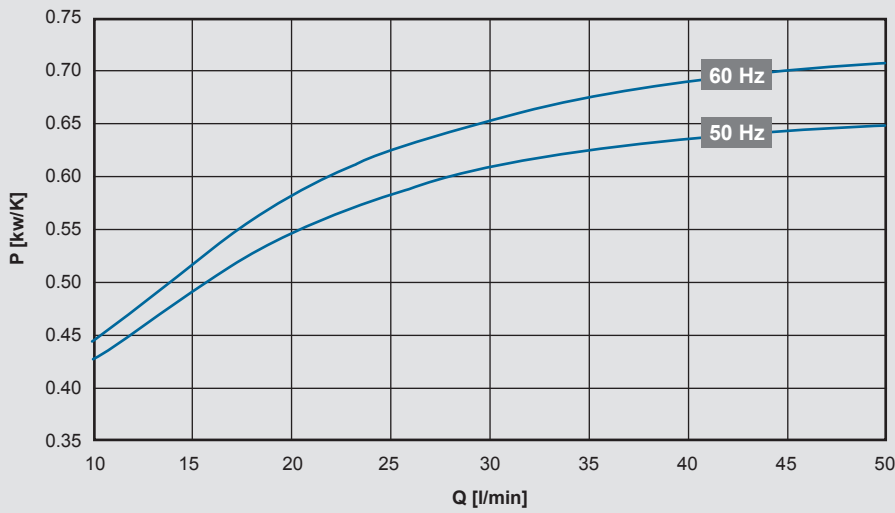

Cooling capacity tolerance: ± 5 %

The cooling capacity is calculated via the following formula:

$$P \text{ [kW]} = P_{\text{spec.}} \text{ [kW/K]} \times \text{ITD} \text{ [K]}$$

ITD (inlet temperature difference) = cooler inlet temperature of operating medium – air inlet temperature

Output data

601 pump version

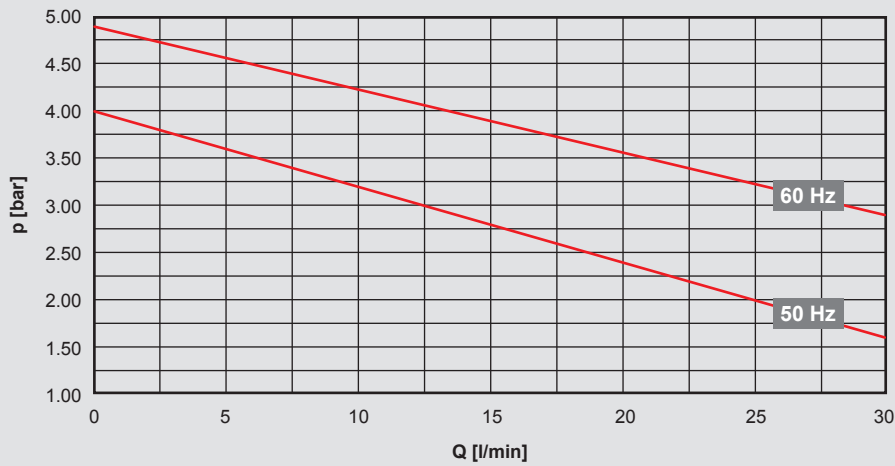

Operating range: 5 – 30 l/min

Electrical data:

Permissible voltage range:
 380 – 420 V – 50 Hz – 3 PH
 400 – 480 V – 60 Hz – 3 PH
 Voltage tolerance +5% / -10%

Motor capacity (50/60 Hz):

Pump: 0.50 / 0.70 kW
 Fan: 0.45 / 0.70 kW

MTH2-6 pump version

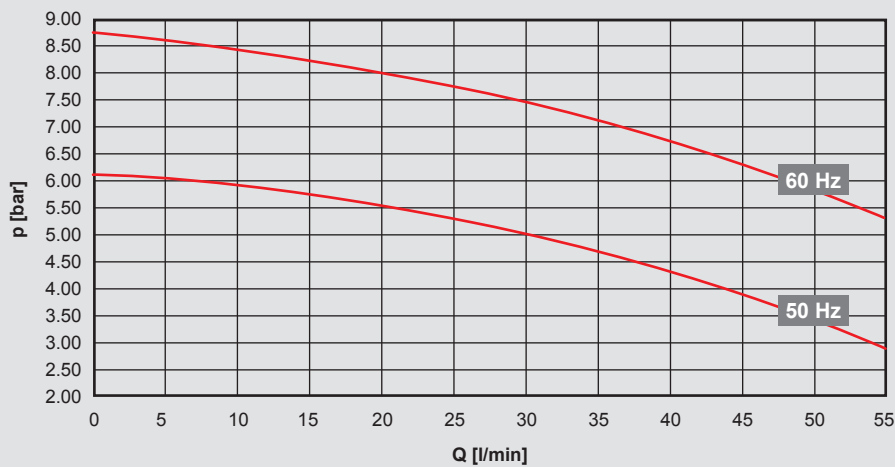

Operating range: 15 – 55 l/min

Output tolerance: ± 9%, pumping head tolerance: ± 7% as per DIN EN ISO 9906 Cl. 2, App. A

Electrical data:

Permissible voltage range:
 380 – 415 V – 50 Hz – 3 PH
 380 – 440 V – 60 Hz – 3 PH
 Voltage tolerance +5% / -10%

Motor capacity (50/60 Hz):

Pump: 0.845 / 1.28 kW
 Fan: 0.45 / 0.70 kW

Note:

The operating point of the pump (flow rate) depends on the characteristic curve (line sizes, line lengths, screwing elements). In general, the less the system losses, the greater the flow rate and the greater the cooling capacity.

Please contact Technical Sales with questions on cooling capacity and output data with other operating fluids, as well as on special voltages or other pumps.

Electrical connection

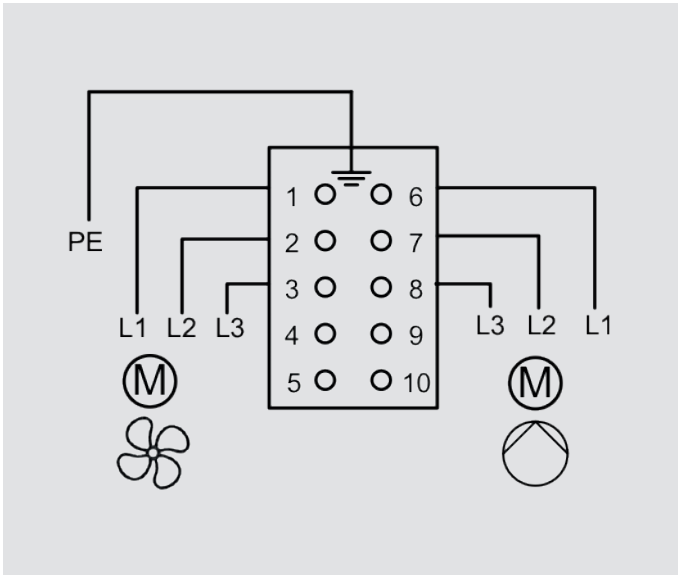

The motor is usually electrically connected using a heavy-duty connector.

E.g. Harting housing 09300101541 and insert 09330102716.

Dimensions

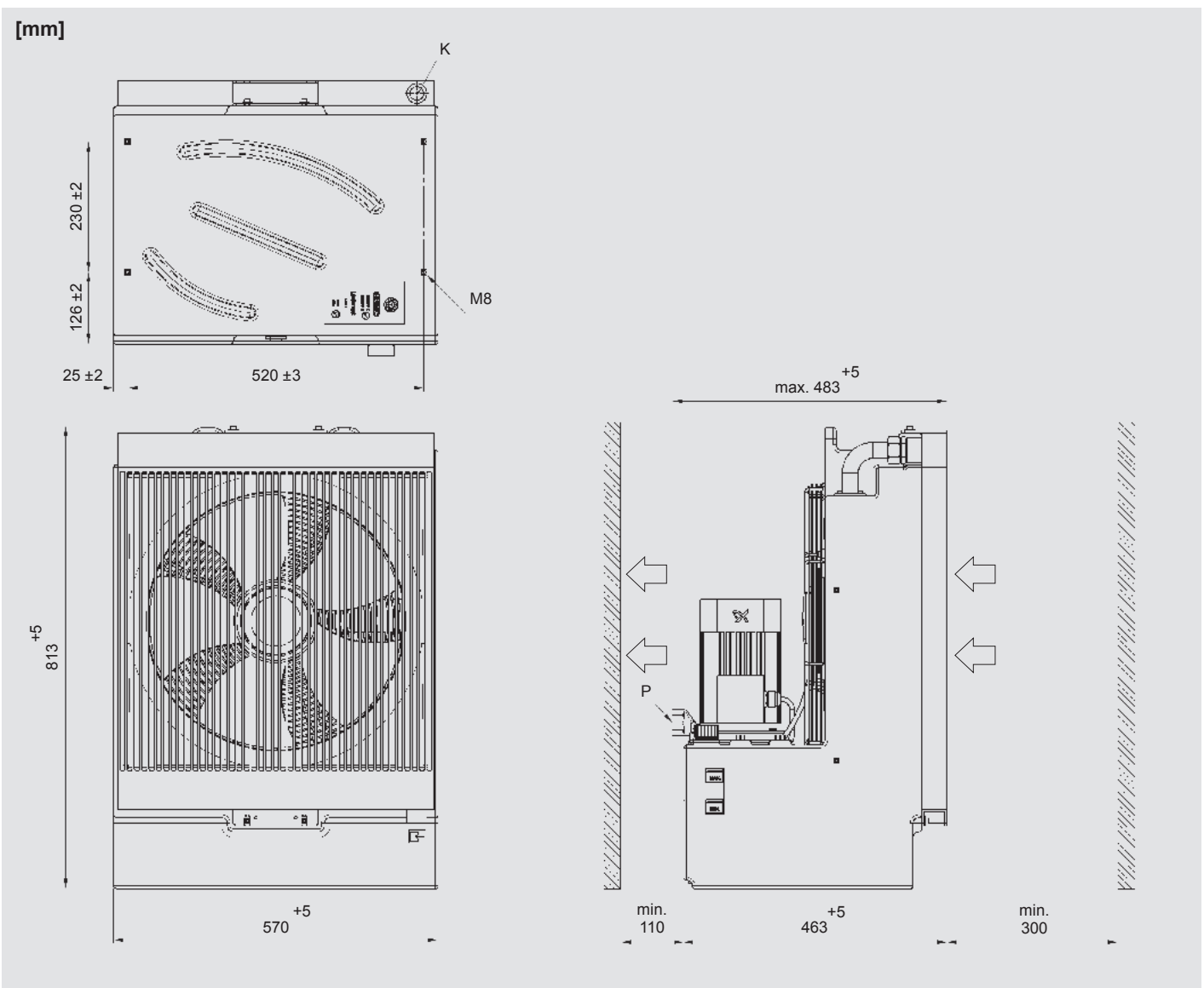

Note:

We recommend maintaining the specified minimum distance to ensure an unimpeded air inlet and air outlet. Anything below the minimum distance can affect cooling capacity and noise emissions.

Model code

FLKS - 4S - 2.0 - W - 601A0 - 0 - 0

Type

FLKS = fluid/air cooling system

Size

Type code

Operating fluid

W = water-glycol (standard)

Pump

601 = version with pump 601
 H2-6 = version with pump MTH2-6
 Other pumps on request.

Motor voltage

A = 380 – 420 V – 50 Hz / 400 – 480 V – 60 Hz, 3PH (pump 601)
 B = 380 – 415 V – 50 Hz / 380 – 440 V – 60 Hz, 3PH (pump MTH2-6)
 See also "electrical data".

Position of pump connection

0 = standard

Coating

0 = none
 (FLKS-4: white plastic tank housing)

Accessories

0 = none (standard)
 For corresponding accessory number, see table.

Accessories

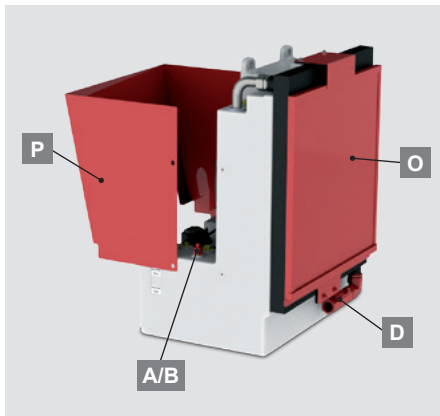

A	Fill level and 60 °C temperature switch		•									•	
B	Fill level switch 2 switch points			•				•				•	
D	Flow switch				•			•			•		
O	Air filter					•		•	•	•	•	•	
P	Air duct						•	•		•		•	
Accessory number		0	1	44	30	14	36	43	59	82	122	124	105

See also "Accessories for FLKS" for more information.

FLKS-4S standard

Part no.	Designation	Pump	Version
3951597	FLKS-4S/2.0/W/601A0/0/0	601	No accessories, fixed speed
3932404	FLKS-4S/2.0/W/H2-6B0/0/0	MTH2-6	No accessories, fixed speed



Fluid/Air Cooling Systems FLKS-4EC with speed control

Symbol

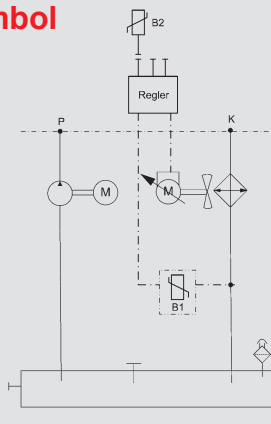

General

The **FLKS-4EC** is a compact fluid / air cooling system with a plastic tank housing, integrated air duct, pump and variable-speed fan.

This lightweight and robust design makes it suitable for diverse applications.

Function

The pump conveys the operating medium from the tank through the part being cooled to the heat exchanger. The axial fan provides the necessary air flow through the heat exchanger to cool the operating medium. The speed can vary depending on the application.

Field of application

- Liquid-cooled drives: motor spindles, torque motors, servo motors, linear motors
- Inverter cooling
- Gearbox cooling and lubrication
- Bearing cooling
- Tool cooling

Technical data

Cooling capacity	Max. 0.70 kW/K (see cooling capacity diagram)
Flow rate	5 – 55 l/min (see output diagrams)
Operating fluid	Version with water glycol (W): Potable water with 35 – 40 % ethylene glycol-based or propylene glycol-based antifreeze and anti-corrosion concentration. Other fluids on request (e.g. mineral oil).
Permitted temperatures	Fluid temperature: max. +60 °C Ambient temperature: 0 °C to +45 °C
Tank volume	31.0 – 43.0 l
Weight	Max. 47 kg
Noise (acoustic pressure)	< 71 dB(A) at 50/60 Hz (at 1 m)
Hydraulic connection	Pump P (flow): G $\frac{3}{4}$ " Heat exchanger K (return): G $\frac{3}{4}$ " If possible, refrain from reducing the size of the line required for the threaded connections.
Electrical connection	The motors are usually electrically connected using a heavy-duty connector.
Mounting position	Pump vertical
Accessories	<ul style="list-style-type: none"> ● Air filter ● Air duct ● Fill level switch ● Fill level and temperature switch ● Flow switch Combinations and other accessories upon request.

Speed control

The temperature sensor of the **FLKS-4EC5** measures the water-glycol outlet temperature from the cooling system. The sensor's 0 – 10 V analogue signal is assigned a temperature range of 25 – 45 °C. The signal is forwarded to the EC fan according to the measured fluid outlet temperature to control the speed. The fan switches on at 1.5 V (= 28 °C) and reaches its maximum speed at 10 V (= 45 °C).

Even at low ambient temperatures, the fluid temperature cannot drop below 28 °C given constant power input. This prevents condensation on electrical components.

Application:

Specially suited for low air temperatures, e.g. outdoors.



Speed control

The **FLKS-4EC3** also comes with a PID controller (closed loop). The temperature sensor measures the fluid outlet temperature (variable). This temperature is continuously compared with the reference value (ambient temperature + set differential $D \Delta T$). The PID controller continually adjusts the speed of the fan, in order to align the fluid temperature with the ambient temperature.

The outlet temperature remains at a set differential above the ambient temperature regardless of the input temperature of the fluid (performance of the machine).

Application:

Particularly for precision cooling (e.g. in machine tools).

Lower fan speed

- = lower sound level
- = lower power consumption
- = lower contamination

Cooling capacity

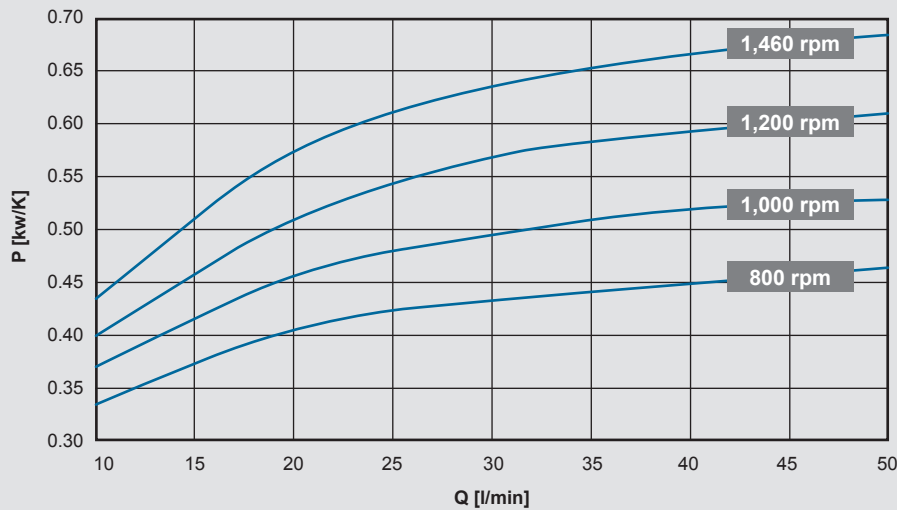

Cooling capacity tolerance: $\pm 5\%$

The cooling capacity is calculated via the following formula:

$$P [\text{kW}] = P_{\text{spec.}} [\text{kW/K}] \times \text{ITD} [\text{K}]$$

ITD (inlet temperature difference) = cooler inlet temperature of operating medium – air inlet temperature

Output data

601 pump version

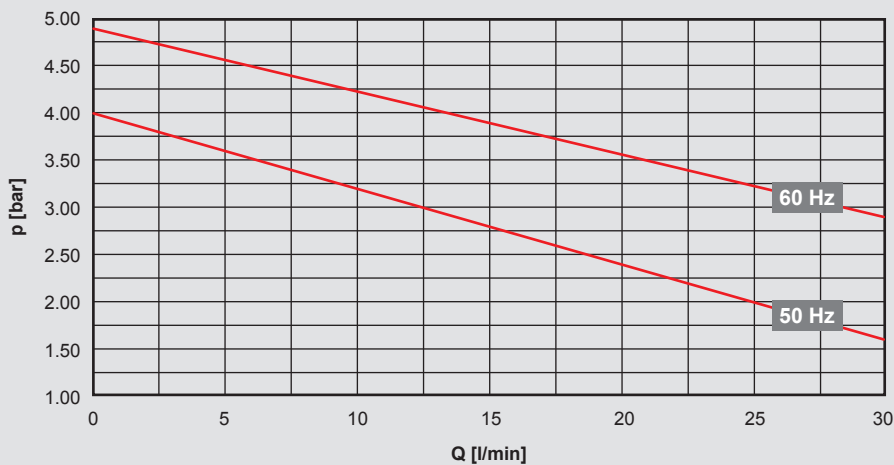

Operating range: 5 – 30 l/min

Electrical data:

Permissible voltage range:
 380 – 420 V – 50 Hz – 3 PH
 400 – 480 V – 60 Hz – 3 PH
 Voltage tolerance +5% / -10%

Motor capacity (50/60 Hz):

Pump: 0.50 / 0.70 kW
 Fan: 0.53 kW

MTH2-6 pump version

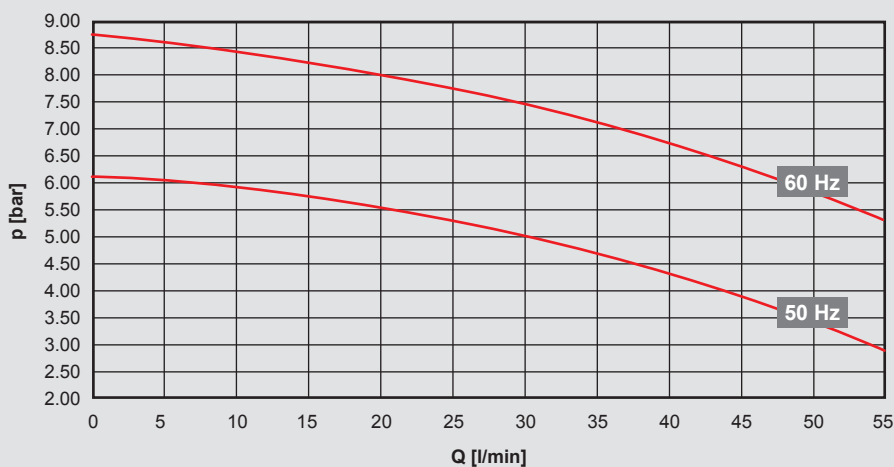

Operating range: 15 – 55 l/min

Output tolerance: $\pm 9\%$, pumping head tolerance: $\pm 7\%$ as per DIN EN ISO 9906 Cl. 2, App. A

Electrical data:

Permissible voltage range:
 380 – 415 V – 50 Hz – 3 PH
 380 – 440 V – 60 Hz – 3 PH
 Voltage tolerance +5% / -10%

Motor capacity (50/60 Hz):

Pump: 0.845 / 1.28 kW
 Fan: 0.53 kW

Note:

The operating point of the pump (flow rate) depends on the characteristic curve (line sizes, line lengths, screwing elements). In general, the less the system losses, the greater the flow rate and the greater the cooling capacity. Please contact Technical Sales with questions on cooling capacity and output data with other operating fluids, as well as on special voltages or other pumps.

Electrical connection

The motor is usually electrically connected using a heavy-duty connector.

Additional 24 V DC control voltage, more information available upon request.

Dimensions

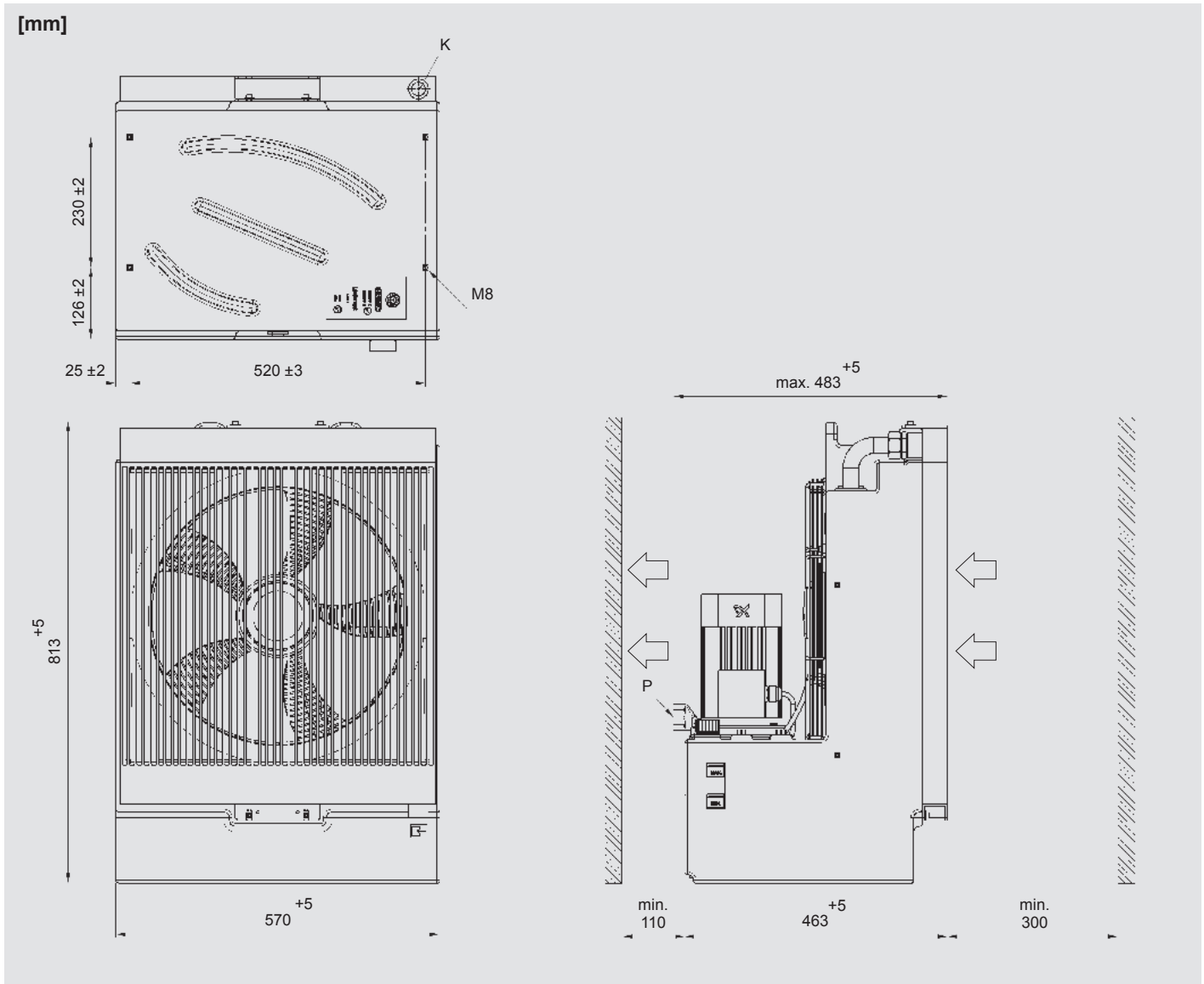

Note:

We recommend maintaining the specified minimum distance to ensure an unimpeded air inlet and air outlet. Anything below the minimum distance can affect cooling capacity and noise emissions.

Model code

FLKS - 4 - EC3 - 2.0 - W - 601A0 - 0 - 0

Type

FLKS = fluid/air cooling system

Size

Speed control (open-loop/closed-loop)

EC3 = speed control, closed-loop (with PID controller)

EC5 = speed control, open-loop (with temperature sensor)

Type code

Operating fluid

W = water-glycol (standard)

Pump

601 = version with pump 601

H2-6 = version with pump MTH2-6

Other pumps on request.

Motor voltage

A = 380 – 420 V – 50 Hz / 400 – 480 V – 60 Hz, 3PH (pump 601)

B = 380 – 415 V – 50 Hz / 380 – 440 V – 60 Hz, 3PH (pump MTH2-6)

See also "electrical data".

Position of pump connection

0 = standard

Coating

0 = none

(FLKS-4: white plastic tank housing)

Accessories

0 = none (standard)

For corresponding accessory number, see table.



Fluid/Air Cooling Systems FLKS-5S/3.x

Symbol

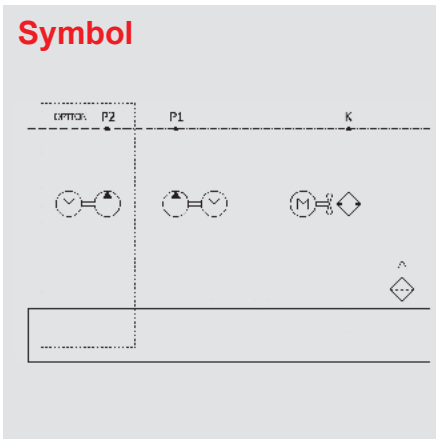

Technical data

Cooling capacity	Max. 1.05 kW/K (see cooling capacity diagram)
Flow rate	5 – 100 l/min (see output diagrams)
Operating fluid	Version with water glycol (W): Potable water with 35 – 40 % ethylene glycol-based or propylene glycol-based antifreeze and anti-corrosion concentration. Other fluids on request (e.g. mineral oil).
Permitted temperatures	Fluid temperature: max. +60 °C Ambient temperature: 0 °C to +45 °C
Tank volume	55.0 – 70.0 l
Weight	65 kg
Noise (acoustic pressure)	69/71 dB(A) at 50/60 Hz (at 1 m)
Hydraulic connection	Pump P (flow): G 3/4" Heat exchanger K (return): G 1" If possible, refrain from reducing the size of the line required for the threaded connections.
Electrical connection	The motors are usually electrically connected using a heavy-duty connector (connection via terminal box available upon request).
Mounting position	Pump vertical
Accessories	<ul style="list-style-type: none"> ● Air filter ● Air duct ● Fill level switch ● Fill level and temperature switch ● Flow switch Combinations and other accessories upon request.

General

The **FLKS-5S** is a compact fluid/air cooling system with a plastic tank housing and integrated air duct. This lightweight and robust design makes it suitable for diverse applications.

For the optional version with two pumps, two cooling circuits with different functions (flow/pressure loss) can be operated.

Function

The pump conveys the operating fluid from the plastic reservoir over the parts being cooled to the heat exchanger.

The axial fan provides the necessary air flow through the heat exchanger to cool the operating medium.

Field of application

- Liquid-cooled drives:
motor spindles, torque motors,
servo motors, linear motors
- Inverter cooling
- Gearbox cooling and lubrication
- Bearing cooling
- Tool cooling

Cooling capacity

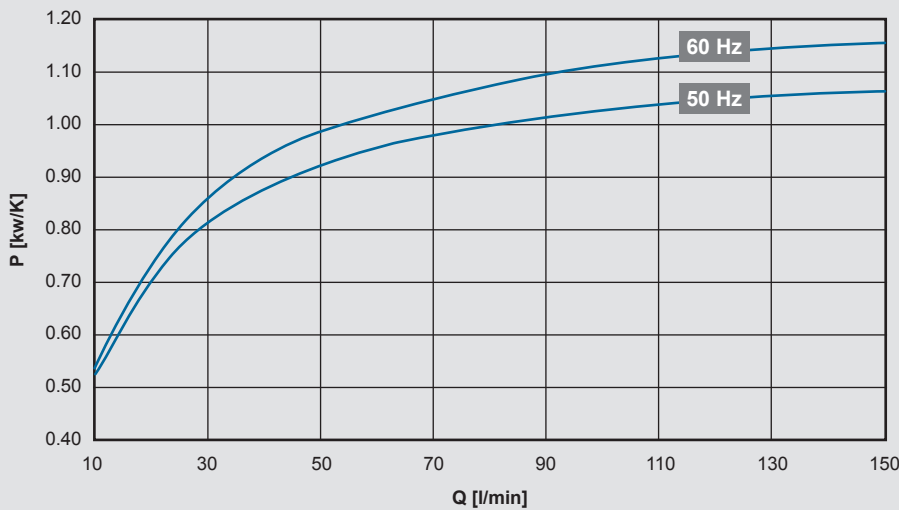

Cooling capacity tolerance: ± 5 %

The cooling capacity is calculated via the following formula:

$$P \text{ [kW]} = P_{\text{spec.}} \text{ [kW/K]} \times \text{ITD} \text{ [K]}$$

ITD (inlet temperature difference) = cooler inlet temperature of operating medium – air inlet temperature

Output data

MTH2-6 pump version

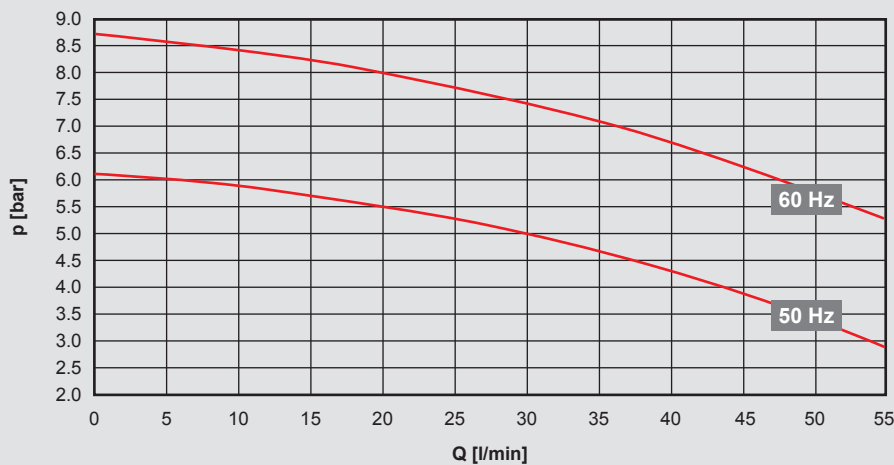

Operating range: 5 – 55 l/min

Electrical data:

Permissible voltage range:
 380 – 415 V – 50 Hz – 3 PH
 380 – 440 V – 60 Hz – 3 PH
 Voltage tolerance +5% / -10%

Motor capacity (50/60 Hz):

Pump: 0.845 / 1.28 kW
 Fan: 0.45 / 0.70 kW

MTH4-4 pump version

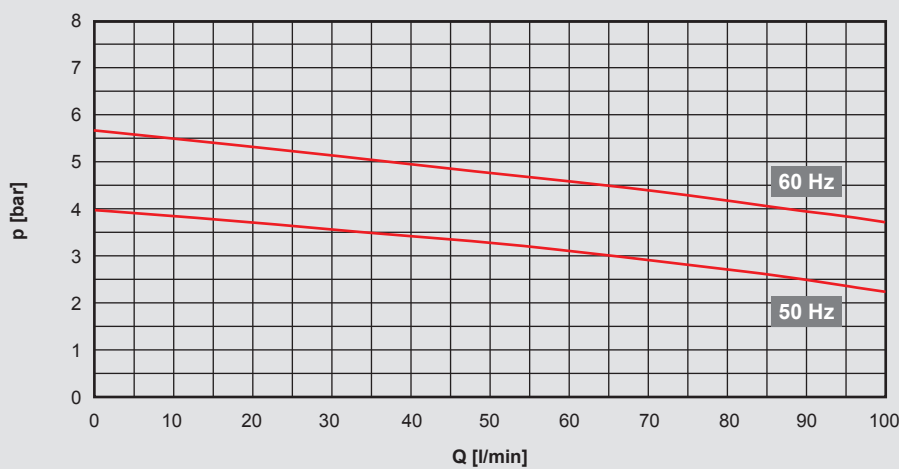

Operating range: 5 – 70 l/min

Output tolerance: ±9%, pumping head tolerance: ±7% as per DIN EN ISO 9906 Cl. 2, App. A

Electrical data:

Permissible voltage range:
 380 – 415 V – 50 Hz – 3 PH
 380 – 440 V – 60 Hz – 3 PH
 Voltage tolerance +5% / -10%

Motor capacity (50/60 Hz):

Pump: 0.96 / 1.51 kW
 Fan: 0.45 / 0.70 kW

The version with two pumps is available on request.

Note:

The operating point of the pump (flow rate) depends on the characteristic curve (line sizes, line lengths, screwing elements). In general, the less the system losses, the greater the flow rate and the greater the cooling capacity.

Please contact Technical Sales with questions on cooling capacity and output data with other operating fluids, as well as on special voltages or other pumps.

Electrical connection

The motor is usually electrically connected using a heavy-duty connector.

For PIN configuration see the data sheet or electric diagram of the FLKS.

Dimensions

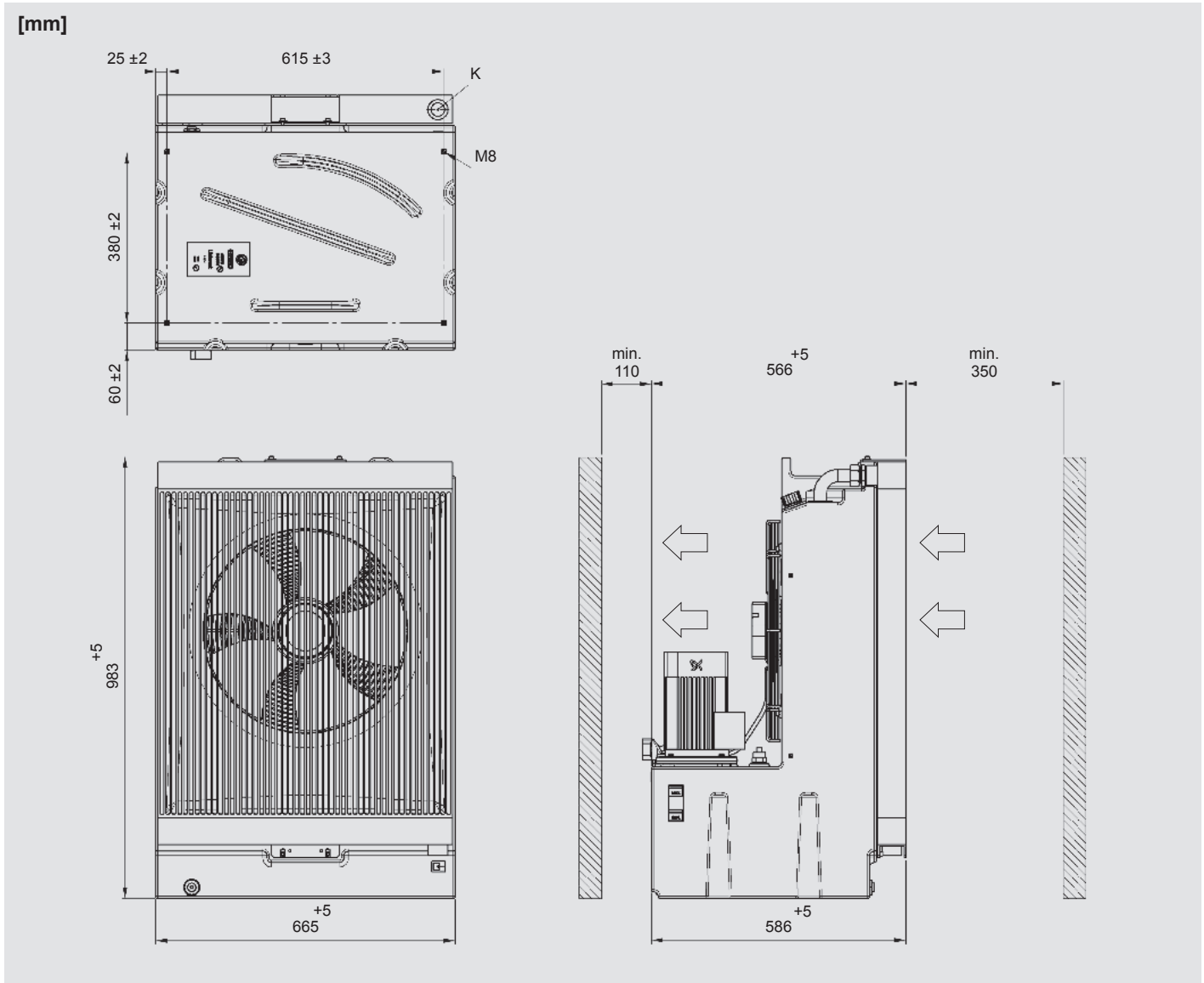

Note:

We recommend maintaining the specified minimum distance to ensure an unimpeded air inlet and air outlet. Anything below the minimum distance can affect cooling capacity and noise emissions.

Model code

FLKS - 5S - 3.0 - W - H4-4B0 - 0 - 0

Type

FLKS = fluid/air cooling system

Size

Type code

Operating fluid

W = water-glycol (standard)

Pump

H2-6 = version with pump MTH2-6

H4-4 = version with pump MTH4-4

Version with two pumps on request.

Motor voltage

B = 380 – 415 V – 50 Hz / 380 – 440 V – 60 Hz, 3PH (pump MTH2-6 and pump MTH4-4)

See also “electrical data”.

Position of pump connection

0 = standard

Coating

0 = none

(FLKS-5: white plastic tank housing)

Accessory number

0 = none (standard)

For corresponding accessory number, see table.

Accessories

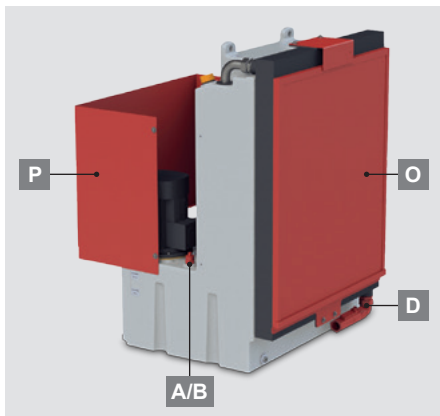

A	Fill level and 60 °C temperature switch		•										•
B	Fill level switch 2 switch points			•				•					•
D	Flow switch				•		•			•			
O	Air filter					•	•	•	•	•	•	•	•
P	Air duct						•	•		•		•	
Accessory number		0	1	44	30	14	36	43	59	82	122	124	105

See also “Accessories for FLKS” for more information.

FLKS-5S/3.x standard

Part no.	Designation	Pump	Version
4143591	FLKS-5S/3.0/W/H2-6B0/0/0	MTH2-6	No accessories, fixed speed
4143682	FLKS-5S/3.0/W/H4-4B0/0/0	MTH4-4	No accessories, fixed speed



Fluid/Air Cooling Systems FLKS-5EC/3.x with speed control

Symbol

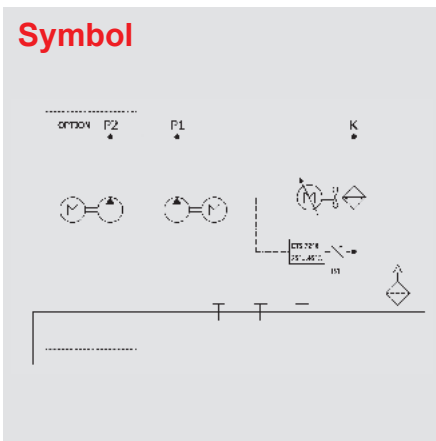

General

The **FLKS-5EC** is a compact fluid / air cooling system with a plastic tank housing, integrated air duct, pump and variable-speed fan.

This lightweight and robust design makes it suitable for diverse applications.

For the optional version with two pumps, two cooling circuits with different functions (flow/pressure loss) can be operated.

Function

The pump conveys the operating medium from the tank through the part being cooled to the heat exchanger. The axial fan provides the necessary air flow through the heat exchanger to cool the operating medium. The speed can vary depending on the application.

Field of application

- Liquid-cooled drives: motor spindles, torque motors, servo motors, linear motors
- Inverter cooling
- Gearbox cooling and lubrication
- Bearing cooling
- Tool cooling

Technical data

Cooling capacity	Max. 1.15 kW/K (see cooling capacity diagram)
Flow rate	5 – 100 l/min (see output diagrams)
Operating fluid	Version with water glycol (W): Potable water with 35 – 40 % ethylene glycol-based or propylene glycol-based antifreeze and anti-corrosion concentration. Other fluids on request (e.g. mineral oil).
Permitted temperatures	Fluid temperature: max. +60 °C Ambient temperature: 0 °C to +45 °C
Tank volume	55.0 – 70.0 l
Weight	Max. 64 kg
Noise (acoustic pressure)	< 71 dB(A) at max. drive speed (at 1 m)
Hydraulic connection	Pump P (flow): G 3/4" Heat exchanger K (return): G 1" If possible, refrain from reducing the size of the line required for the threaded connections.
Electrical connection	The motors are usually electrically connected using a heavy-duty connector.
Mounting position	Pump vertical
Accessories	<ul style="list-style-type: none"> ● Air filter ● Air duct ● Fill level switch ● Fill level and temperature switch ● Flow switch Combinations and other accessories upon request.

Speed control

The temperature sensor of the **FLKS-5EC5** measures the water-glycol outlet temperature from the cooling system. The sensor's 0 – 10 V analogue signal is assigned a temperature range of 25 – 45 °C. The signal is forwarded to the EC fan according to the measured fluid outlet temperature to control the speed. The fan switches on at 1.5 V (= 28 °C) and reaches its maximum speed at 10 V (= 45 °C).

Even at low ambient temperatures, the fluid temperature cannot drop below 28 °C given constant power input. This prevents condensation on electrical components.

Application:

Specially suited for low air temperatures, e.g. outdoors.



Speed control

The **FLKS-5EC3** also comes with a PID controller (closed loop). The temperature sensor measures the fluid outlet temperature (variable). This temperature is continuously compared with the reference value (ambient temperature + set differential $D \Delta T$). The PID controller continually adjusts the speed of the fan, in order to align the fluid temperature with the ambient temperature.

The outlet temperature remains at a set differential above the ambient temperature regardless of the input temperature of the fluid in the cooler (power of the machine).

Application:

Particularly for precision cooling (e.g. in machine tools).

Lower fan speed

- = lower sound level
- = lower power consumption
- = lower contamination

Cooling capacity

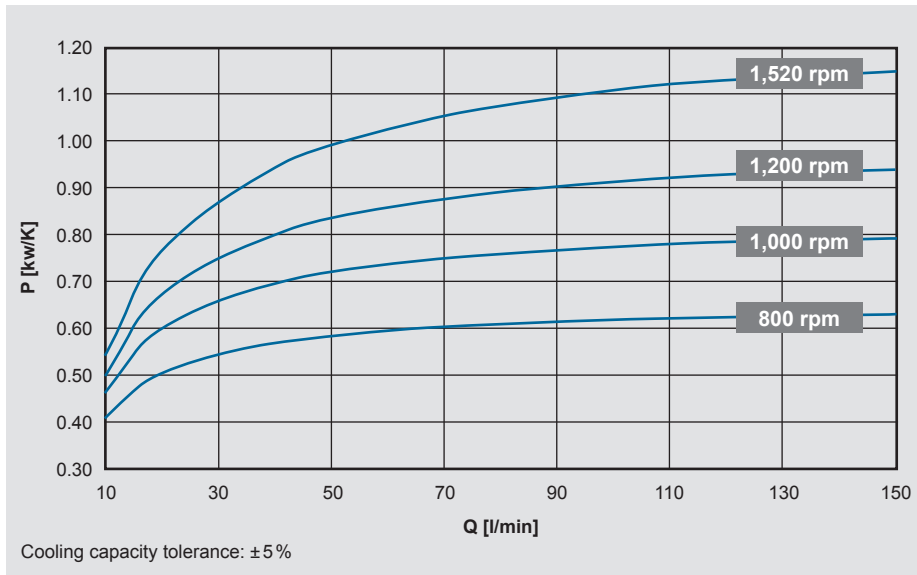

The cooling capacity is calculated via the following formula:

$$P \text{ [kW]} = P_{\text{spec.}} \text{ [kW/K]} \times \text{ITD} \text{ [K]}$$

ITD (inlet temperature difference) = cooler inlet temperature of operating medium – air inlet temperature

Output data

MTH2-6 pump version

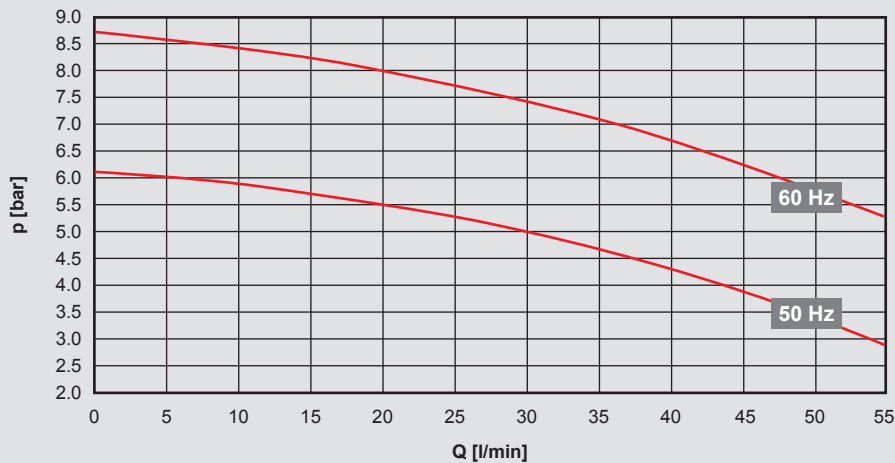

Electrical data:

Permissible voltage range:
 380 – 415 V – 50 Hz – 3 PH
 380 – 440 V – 60 Hz – 3 PH
 Voltage tolerance +5% / -10%

Motor capacity (50/60 Hz):
 Pump: 0.845 / 1.28 kW
 Fan: 0.45 / 0.70 kW

MTH4-4 pump version

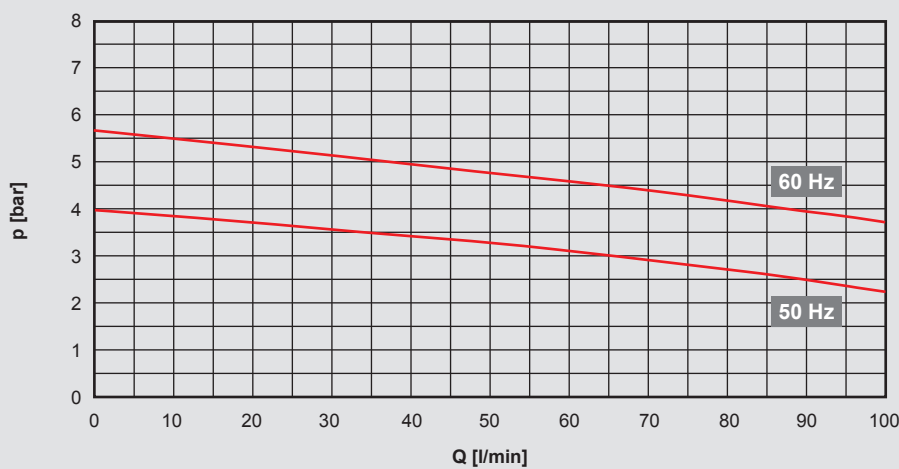

Electrical data:

Permissible voltage range:
 380 – 415 V – 50 Hz – 3 PH
 380 – 440 V – 60 Hz – 3 PH
 Voltage tolerance +5% / -10%

Motor capacity (50/60 Hz):
 Pump: 0.96 / 1.51 kW
 Fan: 0.45 / 0.70 kW

The version with two pumps is available on request.

Note:

The operating point of the pump (flow rate) depends on the characteristic curve (line sizes, line lengths, screwing elements). In general, the less the system losses, the greater the flow rate and the greater the cooling capacity. Please contact Technical Sales with questions on cooling capacity and output data with other operating fluids, as well as on special voltages or other pumps.

Electrical connection

The motor is usually electrically connected using a heavy-duty connector.

For PIN configuration see the data sheet or electric diagram of the FLKS.

Dimensions

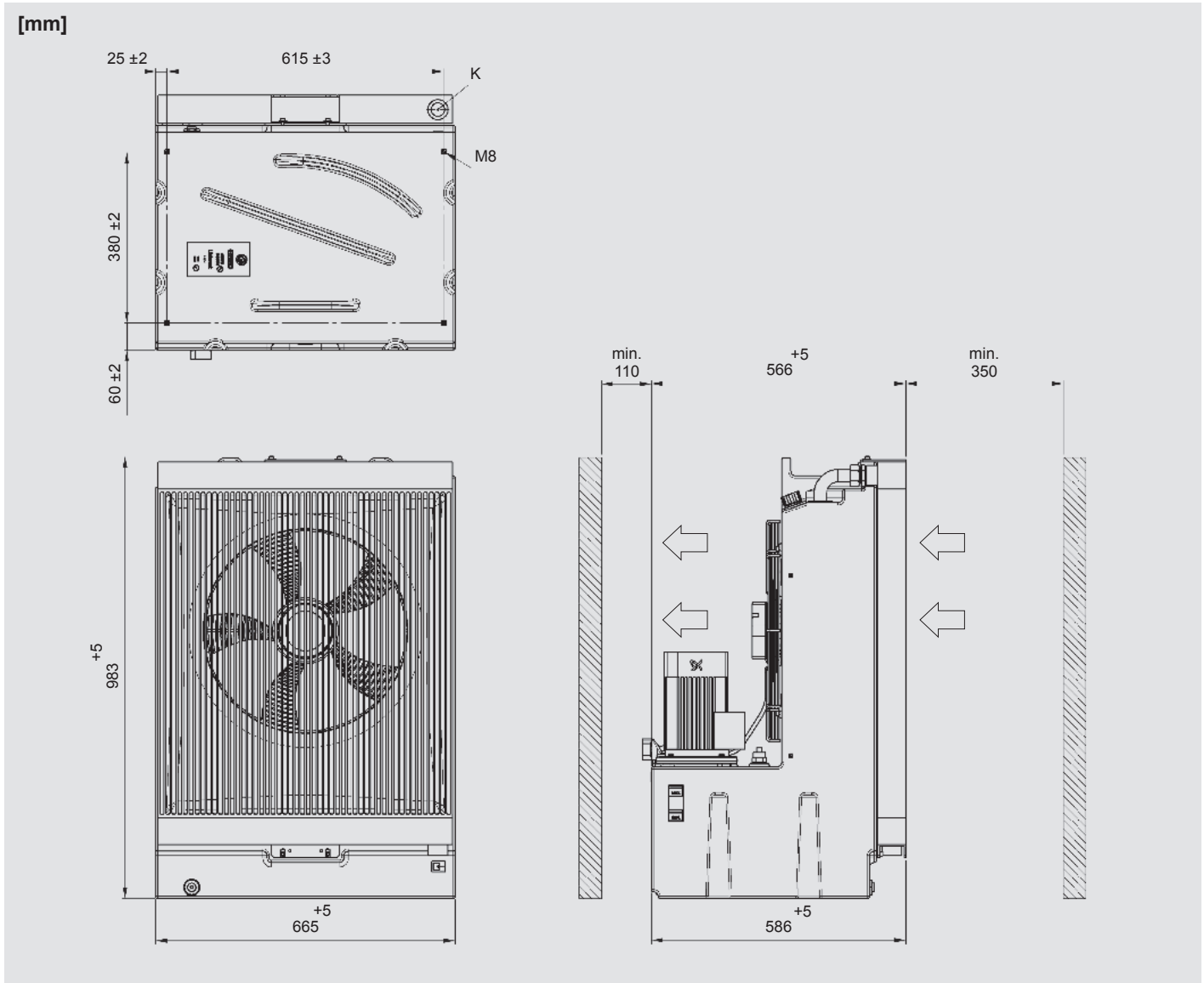

Note:

We recommend maintaining the specified minimum distance to ensure an unimpeded air inlet and air outlet. Anything below the minimum distance can affect cooling capacity and noise emissions.

Model code

FLKS - 5 - EC3 - 3.0 - W - H4-4B0 - 0 - 0

Type

FLKS = fluid/air cooling system

Size

Speed control (open-loop/closed-loop)

EC3 = speed control, closed-loop (with PID controller)

EC5 = speed control, open-loop (with temperature sensor)

Type code

Operating fluid

W = water-glycol (standard)

Pump

H2-6 = version with pump MTH2-6

H4-4 = version with pump MTH4-4

Version with two pumps on request.

Motor voltage

B = 380 – 415 V – 50 Hz / 380 – 440 V – 60 Hz, 3PH (pump MTH2-6 and pump MTH4-4)

See also "electrical data".

Position of pump connection

0 = standard

Coating

0 = none

(FLKS-5: white plastic tank housing)

Accessory number

0 = none (standard)

For corresponding accessory number, see table.

Accessories

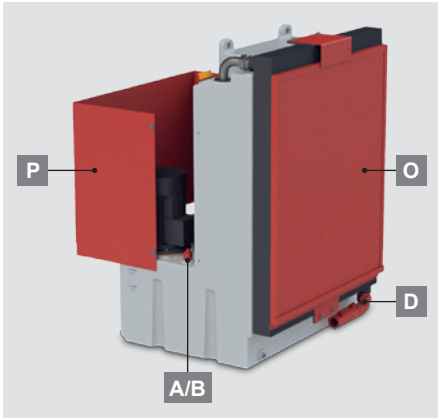

A	Fill level and 60 °C temperature switch		•										•
B	Fill level switch 2 switch points			•					•				•
D	Flow switch				•			•				•	
O	Air filter					•		•	•	•	•	•	•
P	Air duct						•	•		•			•
Accessory number		0	1	44	30	14	36	43	59	82	122	124	105

See also "Accessories for FLKS" for more information.

FLKS-5EC/3.x standard

Part no.	Designation	Pump	Version
4143685	FLKS-5EC3/3.0/W/H2-6B0/0/0	MTH2-6	Speed control
4143691	FLKS-5EC3/3.0/W/H4-4B0/0/0	MTH4-4	Speed control

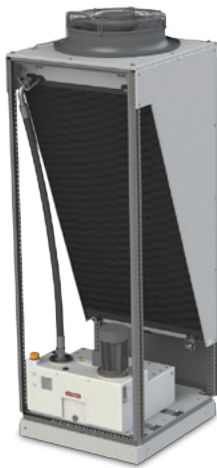

Fluid/Air Cooling Systems FLKS-8EC with speed control

Symbol

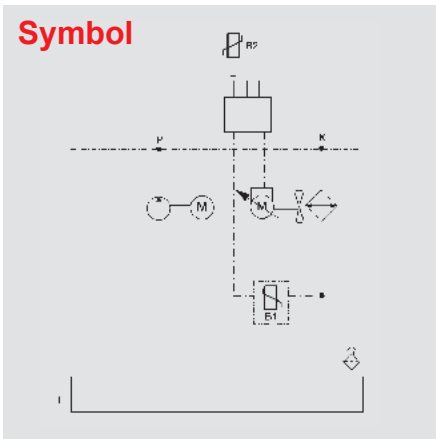

Technical data

Cooling capacity	Max. 2.00 kW/K (see cooling capacity diagram)
Flow rate	max. 150 l/min (see output diagrams)
Operating fluid	Version with water glycol (W): Potable water with 35 – 40 % ethylene glycol-based or propylene glycol-based antifreeze and anti-corrosion concentration. Other fluids on request (e.g. mineral oil).
Permitted temperatures	Fluid temperature: max. +60 °C Ambient temperature: 0 °C to +45 °C
Tank volume	70 / 110 l
Weight	Max. 235 kg (open version) Max. 275 kg (closed version)
Noise (acoustic pressure)	< 77 dB(A) at max. drive speed (at 1 m)
Hydraulic connection	Pump P (flow): G 3/4" / G 2" Heat exchanger K (return): G 1 1/4" If possible, refrain from reducing the size of the line required for the threaded connections.
Electrical connection	The motors are usually electrically connected using a heavy-duty connector.
Mounting position	Pump vertical
Accessories	<ul style="list-style-type: none"> ● Air filter (optional for open version, standard for closed version) ● Fill level switch ● Fill level and temperature switch ● Flow switch Combinations and other accessories upon request.

General

The **FLKS-8EC** is a fluid/air cooling system with reversing pump, plastic tank, heat exchanger and variable-speed fan. This FLKS was specially designed for high flow rates and high cooling capacities.

Function

The pump conveys the operating medium from the tank through the part being cooled to the heat exchanger. The axial fan provides the necessary air flow through the heat exchanger to cool the operating medium. The speed can vary depending on the application.

Field of application

- Liquid-cooled drives:
motor spindles, torque motors,
servo motors, linear motors
- Inverter cooling
- Gearbox cooling and lubrication
- Bearing cooling
- Tool cooling

Versions

In addition to the standard upright and open version, the FLKS-8EC is also available with a closed housing and in a horizontal version.

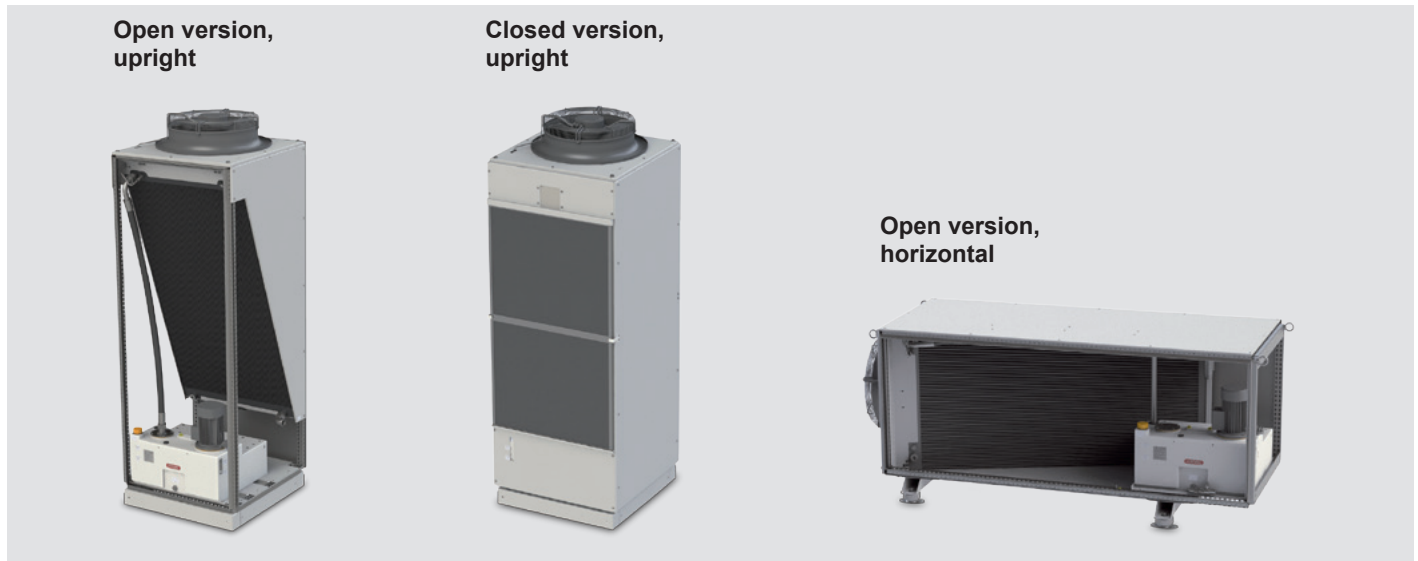

Speed control

The temperature sensor of the **FLKS-8EC5** measures the water-glycol outlet temperature from the cooling system. The sensor's 0 – 10 V analogue signal is assigned a temperature range of 25 – 45 °C. The signal is forwarded to the EC fan according to the measured fluid outlet temperature to control the speed. The fan switches on at 1.5 V (= 28 °C) and reaches its maximum speed at 10 V (= 45 °C).

Even at low ambient temperatures, the fluid temperature cannot drop below 28 °C given constant power input. This prevents condensation on electrical components.

Application:

Specially suited for low air temperatures, e.g. outdoors.



Speed control

The **FLKS-8EC3** also comes with a PID controller (closed loop). The temperature sensor measures the fluid outlet temperature (variable). This temperature is continuously compared with the reference value (ambient temperature + set differential $D \Delta T$). The PID controller continually adjusts the speed of the fan, in order to align the fluid temperature with the ambient temperature.

The outlet temperature remains at a set differential above the ambient temperature regardless of the input temperature of the fluid in the cooler (power of the machine).

Application:

Particularly for precision cooling (e.g. in machine tools).

Lower fan speed

- = lower sound level
- = lower power consumption
- = lower contamination

Cooling capacity

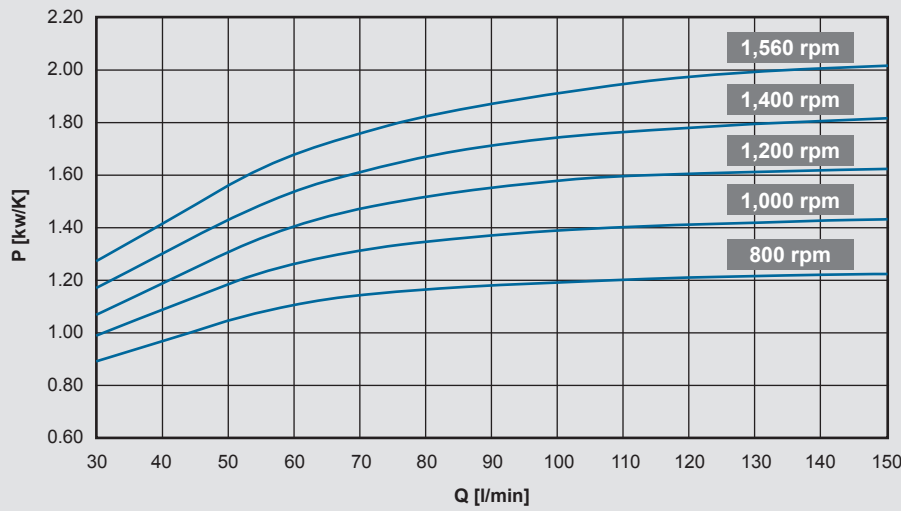

Cooling capacity tolerance: $\pm 5\%$

The cooling capacity is calculated via the following formula:

$$P \text{ [kW]} = P_{\text{spec.}} \text{ [kW/K]} \times \text{ITD} \text{ [K]}$$

ITD (inlet temperature difference) = cooler inlet temperature of operating medium – air inlet temperature

Output data

MTH4-6 pump version

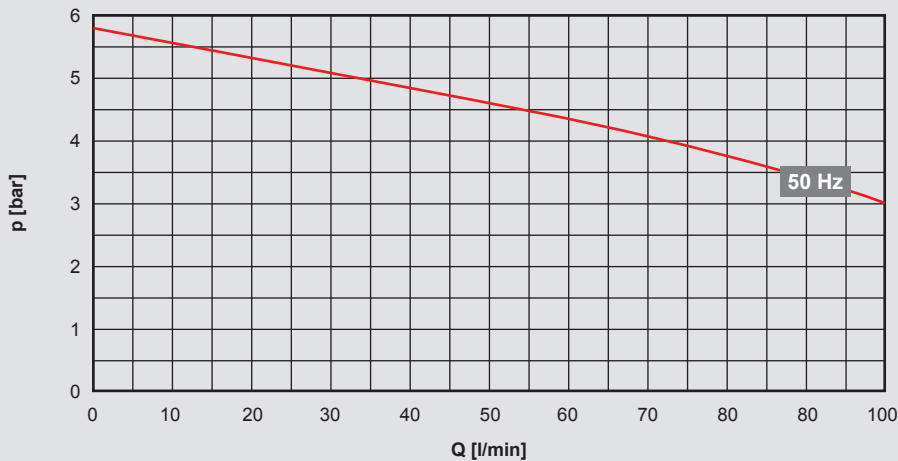

Operating range: 30 – 100 l/min

Electrical data:

Permissible voltage range:
380 – 415 V – 50 Hz – 3 PH
Voltage tolerance +5% / -10%

Motor capacity (50 Hz):

Pump: 1.34 kW
Fan: 0.98 kW

MTR10-6 pump version

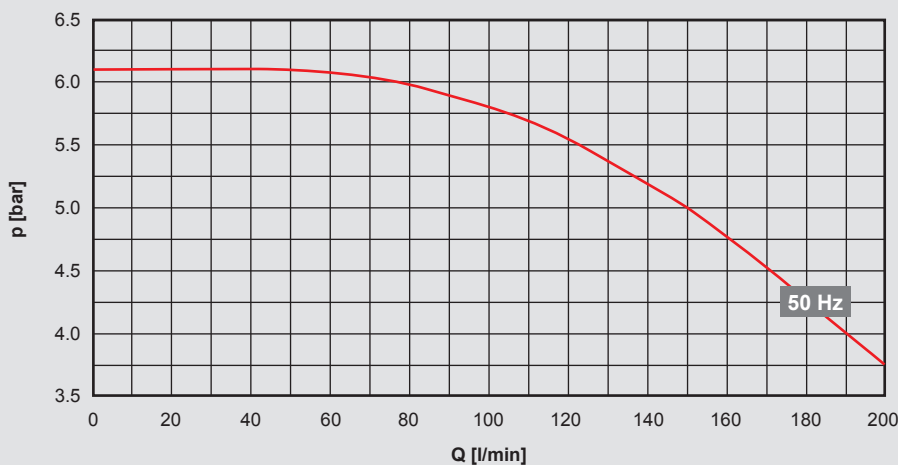

Operating range: 35 – 150 l/min

Output tolerance: $\pm 9\%$, pumping head tolerance: $\pm 7\%$ as per DIN EN ISO 9906 Cl. 2, App. A

Electrical data:

Permissible voltage range:
380 – 415 V – 50 Hz – 3 PH
Voltage tolerance +5% / -10%

Motor capacity (50 Hz):

Pump: 2.20 kW
Fan: 0.98 kW

Note:

The operating point of the pump (flow rate) depends on the characteristic curve (line sizes, line lengths, screwing elements). In general, the less the system losses, the greater the flow rate and the greater the cooling capacity. Please contact Technical Sales with questions on cooling capacity and output data with other operating fluids, as well as on special voltages or other pumps.

Electrical connection

The motor is usually electrically connected using a heavy-duty connector.

Additional 24 V DC control voltage, more information available upon request.

Dimensions

[mm]

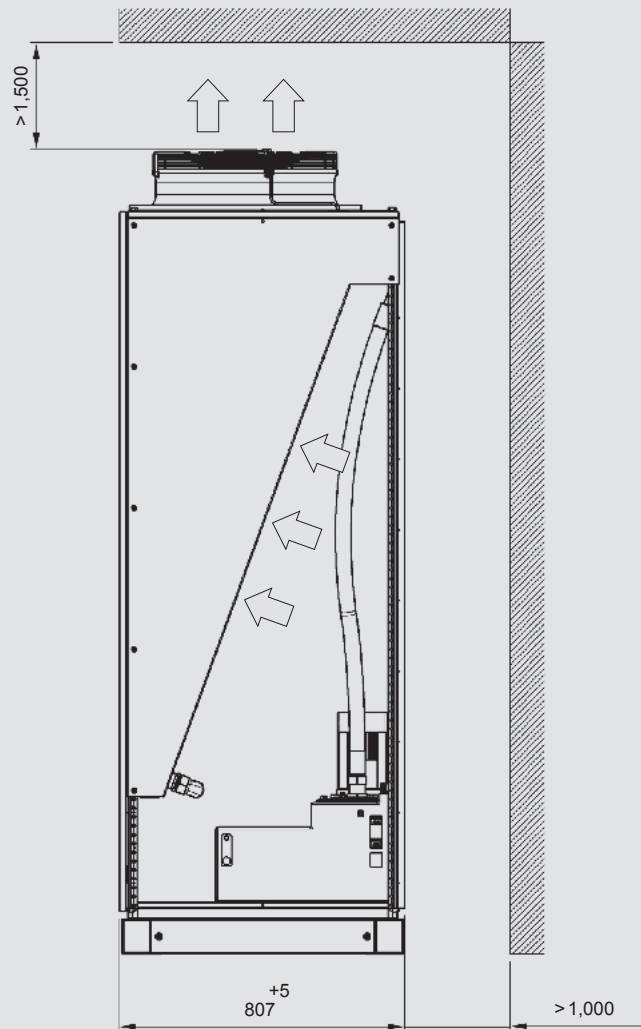
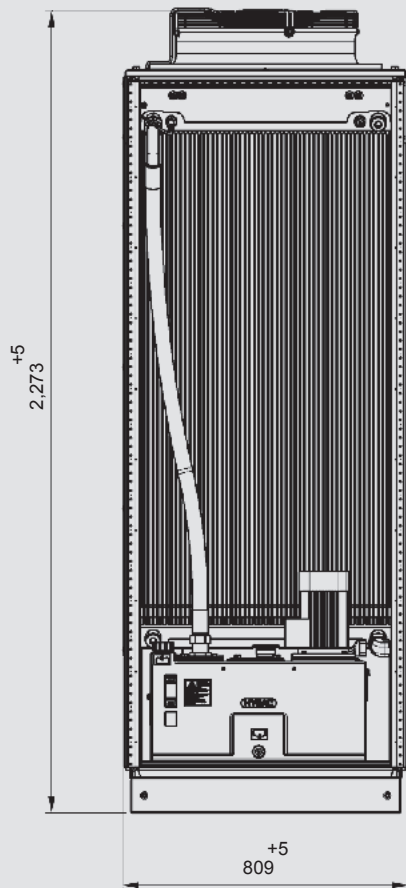
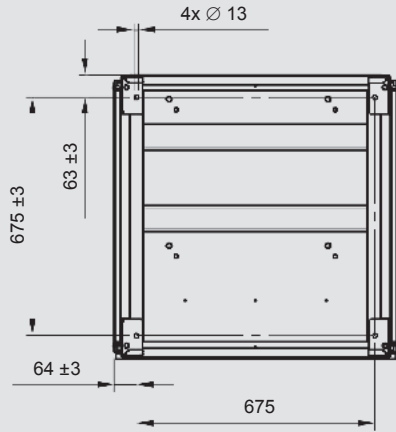

Note:

We recommend maintaining the specified minimum distance to ensure an unimpeded air inlet and air outlet. Anything below the minimum distance can affect cooling capacity and noise emissions.

Model code

FLKS - 8 - EC5 - 1.1 - W - H4-6C3 - 2 - 0

Type

FLKS = fluid/air cooling system

Size

Speed control (open-loop/closed-loop)

EC3 = speed control, closed-loop (with PID controller)

EC5 = speed control, open-loop (with temperature sensor)

Type code

Operating fluid

W = water-glycol (standard)

Pump

H4-6 = version with pump MTH4-6

R10-6 = version with pump MTR10-6

Motor voltage

C = 380 – 415 V – 50 Hz (pump MTH4-6 and pump MTR10-6)

See also “electrical data”.

Position of pump connection

3 = rotated by 270° (clockwise)

Coating

2 = Light grey RAL 7035

Accessory number

0 = none (standard)

For corresponding accessory number, see table.

Accessories

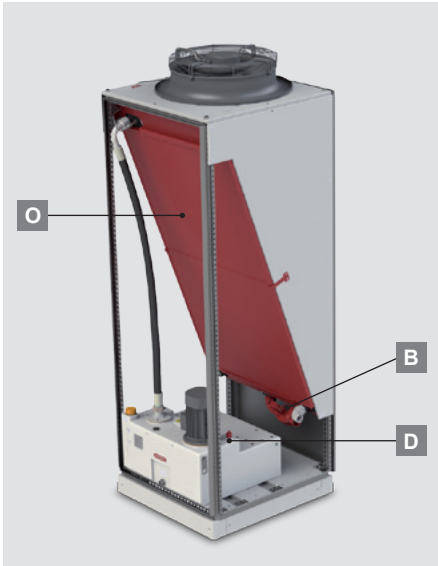

B	Fill level switch 2 switch points			•				•			•
D	Flow switch				•		•			•	
O	Air filter					•	•	•	•	•	•
Accessory number		0	44	30	14	43	59	82	122	124	

See also "Accessories for FLKS" for more information.

FLKS-5EC standard

Part no.	Designation	Pump	Version
4037512	FLKS-8EC5/1.1/W/H4-6C3/2/0	MTH4-6	Open, upright version, speed control, open-loop
4108524	FLKS-8EC6/2.0/W/H4-6C2/2/14	MTH4-6	Closed, upright version, speed control, open-loop
4153106	FLKS-8EC5/3.1/W/H4-6C3/2/0	MTH4-6	Open, horizontal version, speed control, open-loop



Fluid/Air Cooling Systems FLKS-10EC with speed control

Symbol

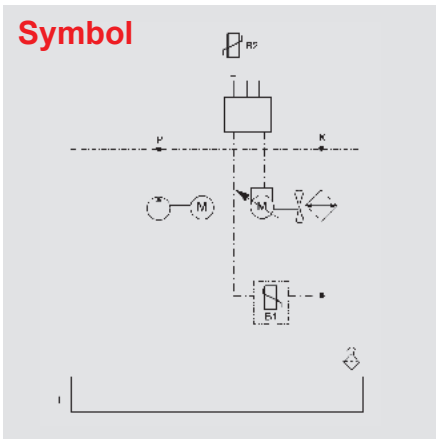

Technical data

Cooling capacity	Max. 4.00 kW/K (see cooling capacity diagram)
Flow rate	max. 300 l/min (see output diagrams)
Operating fluid	Version with water glycol (W): Potable water with 35 – 40 % ethylene glycol-based or propylene glycol-based antifreeze and anti-corrosion concentration. Other fluids on request (e.g. mineral oil).
Permitted temperatures	Fluid temperature: max. +60 °C Ambient temperature: 0 °C to +45 °C
Tank volume	110 l
Weight	Max. 400 kg (open version) Max. 485 kg (closed version)
Noise (acoustic pressure)	< 80 dB(A) at max. drive speed (at 1 m)
Hydraulic connection	Pump P (flow): G2" Heat exchanger K (return): G1½" If possible, refrain from reducing the size of the line required for the threaded connections.
Electrical connection	The motors are usually electrically connected using a heavy-duty connector.
Mounting position	Pump vertical
Accessories	<ul style="list-style-type: none"> ● Air filter (optional for open version, standard for closed version) ● Fill level switch ● Fill level and temperature switch ● Flow switch Combinations and other accessories upon request.

General

The **FLKS-10EC** is a fluid/air cooling system with reversing pump, plastic tank, heat exchanger and variable-speed fan. This FLKS was specially designed for high flow rates and high cooling capacities.

Function

The pump conveys the operating medium from the tank through the part being cooled to the heat exchanger. The axial fan provides the necessary air flow through the heat exchanger to cool the operating medium. The speed can vary depending on the application.

Field of application

- Liquid-cooled drives:
motor spindles, torque motors,
servo motors, linear motors
- Inverter cooling
- Gearbox cooling and lubrication
- Bearing cooling
- Tool cooling

Versions

In addition to the standard upright and open version, the FLKS-10EC is also available with a closed housing.

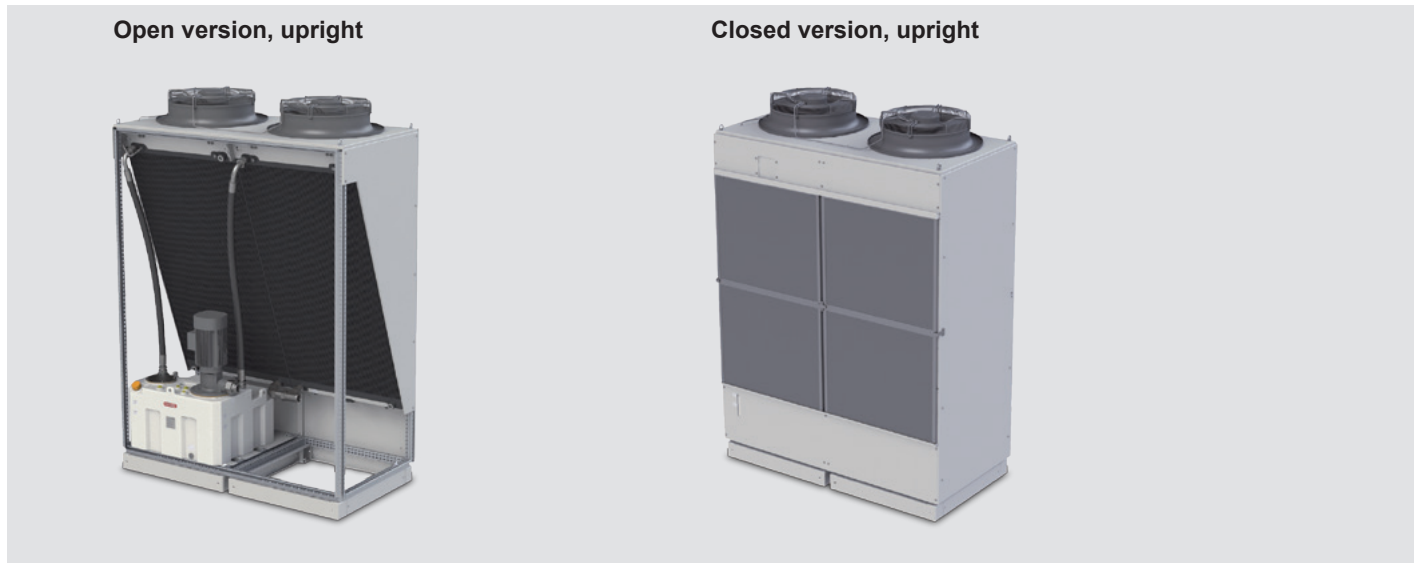

Speed control

The temperature sensor of the **FLKS-10EC5** measures the water-glycol outlet temperature from the cooling system. The sensor's 0 – 10 V analogue signal is assigned a temperature range of 25 – 45 °C. The signal is forwarded to the EC fan according to the measured fluid outlet temperature to control the speed. The fan switches on at 1.5 V (= 28 °C) and reaches its maximum speed at 10 V (= 45 °C).

Even at low ambient temperatures, the fluid temperature cannot drop below 28 °C given constant power input. This prevents condensation on electrical components.

Application:

Specially suited for low air temperatures, e.g. outdoors.



Speed control

The **FLKS-10EC3** also comes with a PID controller (closed loop). The temperature sensor measures the fluid outlet temperature (variable). This temperature is continuously compared with the reference value (ambient temperature + set differential ΔT). The PID controller continually adjusts the speed of the fan, in order to align the fluid temperature with the ambient temperature.

The outlet temperature remains at a set differential above the ambient temperature regardless of the input temperature of the fluid in the cooler (power of the machine).

Application:

Particularly for precision cooling (e.g. in machine tools).

Lower fan speed

- = lower sound level
- = lower power consumption
- = lower contamination

Cooling capacity

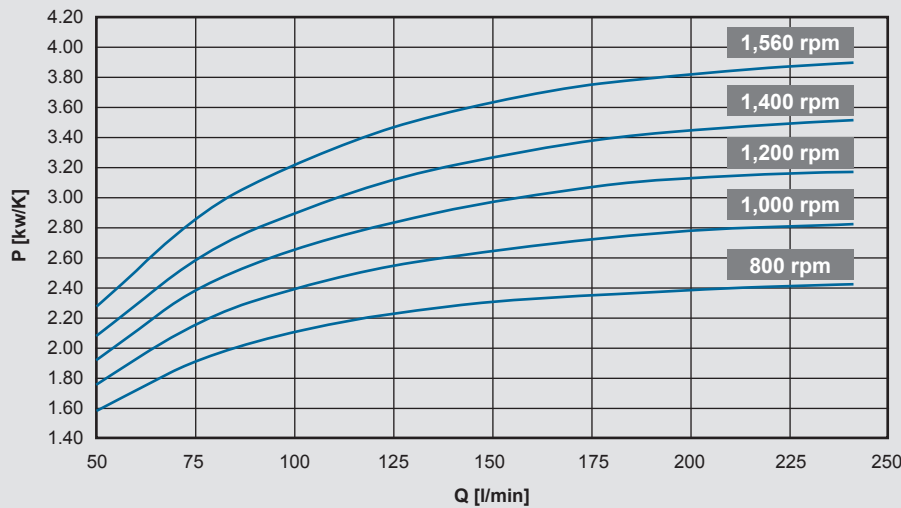

Cooling capacity tolerance: $\pm 5\%$

The cooling capacity is calculated via the following formula:

$$P \text{ [kW]} = P_{\text{spec.}} \text{ [kW/K]} \times \text{ITD} \text{ [K]}$$

ITD (inlet temperature difference) = cooler inlet temperature of operating medium – air inlet temperature

Output data

MTR10-6 pump version

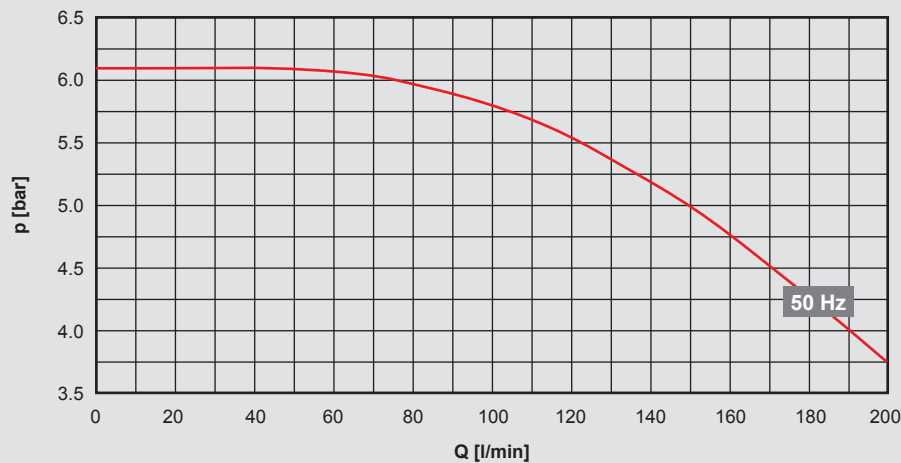

Operating range: 35 – 190 l/min

Electrical data:

Permissible voltage range:
380 – 415 V – 50 Hz – 3 PH
Voltage tolerance +5% / -10%

Motor capacity (50 Hz):
Pump: 2.20 kW
Fan: 2 x 0.98 kW

MTR15-4 pump version

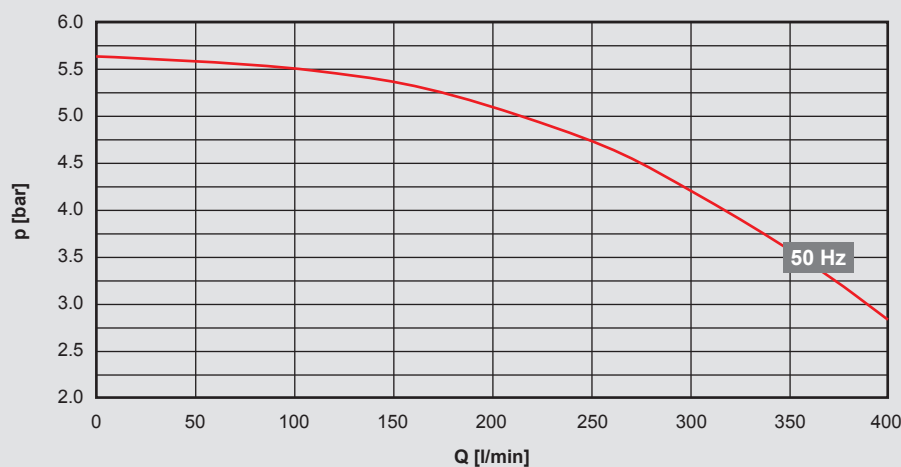

Operating range: 150 – 300 l/min

Output tolerance: $\pm 9\%$, pumping head tolerance: $\pm 7\%$ as per DIN EN ISO 9906 Cl. 2, App. A

Electrical data:

Permissible voltage range:
380 – 415 V – 50 Hz – 3 PH
Voltage tolerance +5% / -10%

Motor capacity (50 Hz):
Pump: 4.00 kW
Fan: 2 x 0.98 kW

Note:

The operating point of the pump (flow rate) depends on the characteristic curve (line sizes, line lengths, screwing elements). In general, the less the system losses, the greater the flow rate and the greater the cooling capacity. Please contact Technical Sales with questions on cooling capacity and output data with other operating fluids, as well as on special voltages or other pumps.

Electrical connection

The motor is usually electrically connected using a heavy-duty connector.

Additional 24 V DC control voltage, more information available upon request.

Dimensions

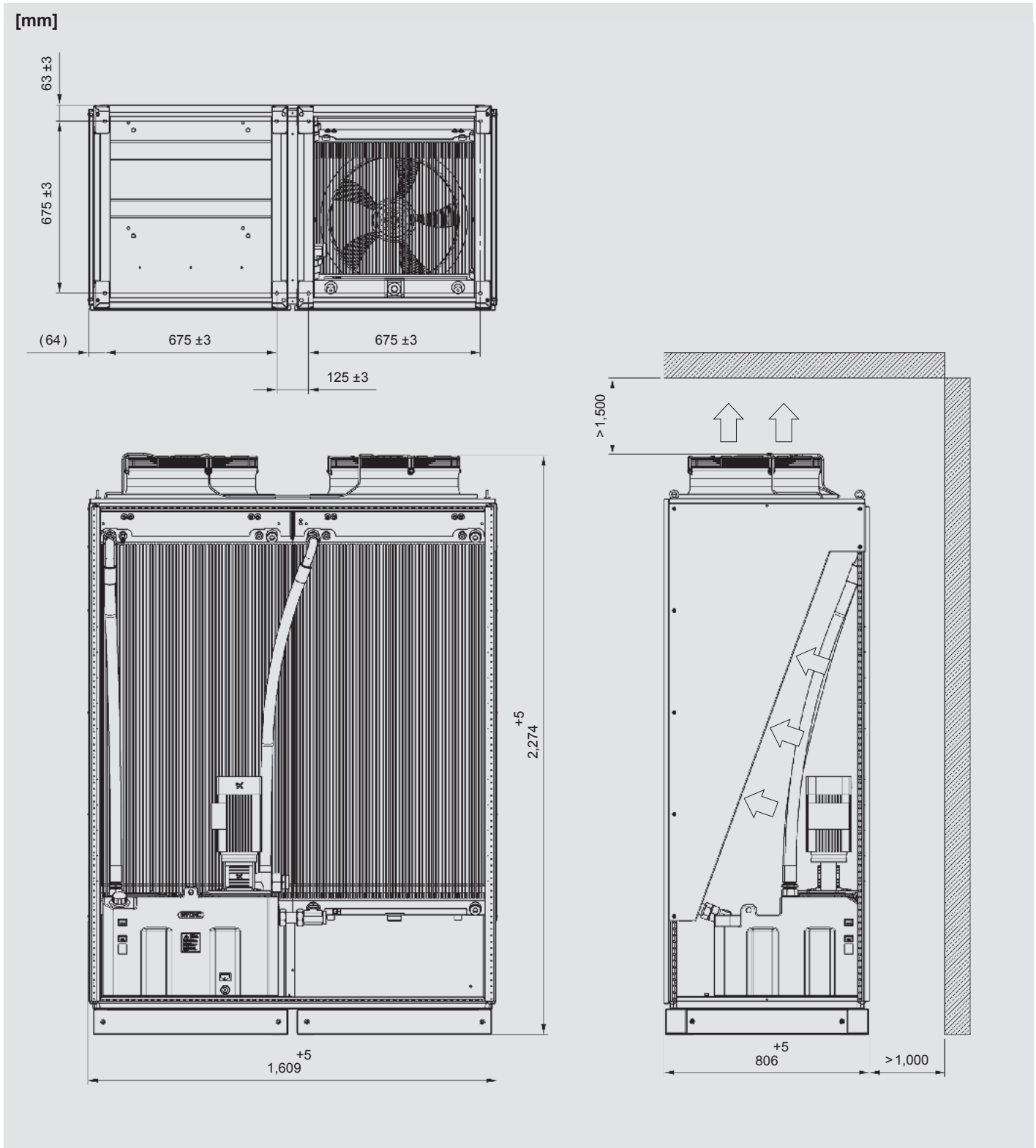

Note:

We recommend maintaining the specified minimum distance to ensure an unimpeded air inlet and air outlet. Anything below the minimum distance can affect cooling capacity and noise emissions.

Model code

FLKS - 10 - EC2 - 2.0 - W - R10-6C3 - 2 - 0

Type

FLKS = fluid/air cooling system

Size

Speed control (open-loop/closed-loop)

EC2 = speed control, closed-loop (with PID controller)

EC5 = speed control, open-loop (with temperature sensor)

Type code

Operating fluid

W = water-glycol (standard)

Pump

R10-6 = version with pump MTR10-6

R15-4 = version with pump MTR15-4

Version with two pumps on request.

Motor voltage

C = 380 – 415 V – 50 Hz (pump MTR10-6 and pump MTR15-4)

See also "electrical data".

Position of pump connection

3 = rotated by 270° (clockwise)

Coating

2 = Light grey RAL 7035

Accessory number

0 = none (standard)

For corresponding accessory number, see table.

Accessories



B	Fill level switch 2 switch points		•				•			•
D	Flow switch			•		•			•	
O	Air filter				•	•	•	•	•	•
Accessory number		0	44	30	14	43	59	82	122	124

See also "Accessories for FLKS" for more information.

FLKS-10EC standard

Part no.	Designation	Pump	Version
4051523	FLKS-10EC5/1.0/W/R10-6C3/2/0	MTR10-6	Open, upright version, speed control, closed-loop
4115359	FLKS-10EC2/2.0/W/R10-6C3/2/0	MTR10-6	Closed, upright version, speed control, closed-loop

FLKS Accessories

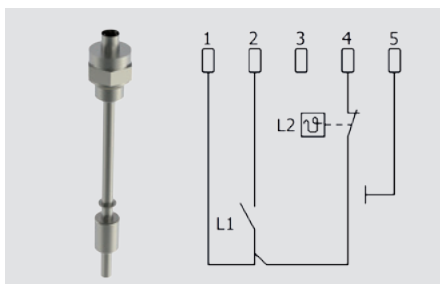

Fill Level and Temperature Switch

For monitoring the level and temperature of the operating medium in the tank.

- 1 fill level switch point
- 1 fixed temperature switch point of 60 °C

Accessory number: 1

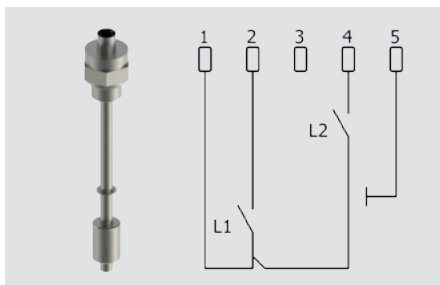

Fill Level Switch (2 switch points)

For monitoring the level of the operating medium in the tank.

Accessory number: 44

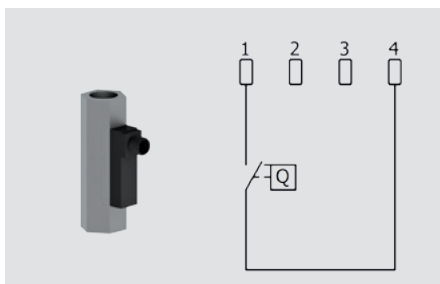

Flow Switch

For monitoring the continuous flow of the operating medium.

Accessory number: 30

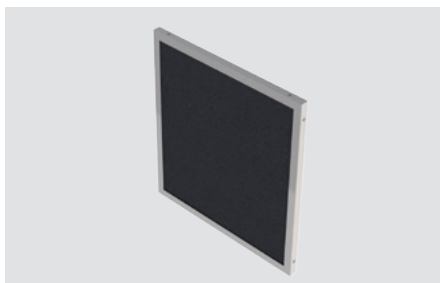

Air Filter Grid

Mounted in front of the heat exchanger to prevent dust and dry particles from entering that could contaminate the heat exchanger.

Accessory number: 14



Air Duct

For directing the flow of air upward.

Accessory number: 36

Possible accessory combinations

Fill level and 60 °C temperature switch		•										•
Fill level switch 2 switch points			•					•			•	
Flow switch				•			•			•		
Air filter					•		•	•	•	•	•	•
Air duct						•	•		•		•	
Accessory number in model code	0	1	44	30	14	36	43	59	82	122	124	105

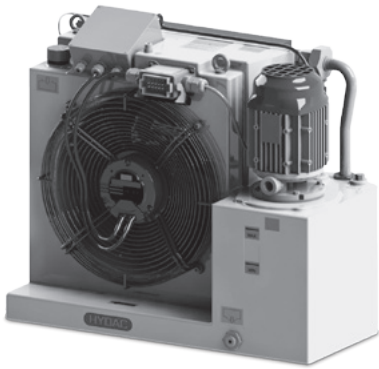

Fluid/Air Cooling Systems

Systems with closed-loop speed control
FLKS-2EC, FLKS-3EC, FLKS-4EC,
FLKS-5EC, FLKS-8EC and FLKS-10EC



FLKS – systematic closed-loop control

Noise reduction and energy savings – these are two of the biggest issues of the future in mechanical engineering.

FLKS – Fluid-air cooling systems – are cooling, as the name indicates, with air. A fan ensures that the necessary air flow is present to cool down the warm fluid in the cooling element. In a conventional fan with a fixed speed, the fan begins to run as soon as the cooling system starts up, irrespective of the ambient temperature and the power input from the consumer. This fan constantly uses energy and creates permanent noise.

Systems with open-loop and closed-loop speed control can change this: at low ambient temperatures the fan still runs but at a low speed; if the inlet temperature to the cooler is only just over the needed outlet temperature (e.g. if the machine is at a standstill due to a tool change and therefore only a little heat is fed into the medium), the speed is also reduced.

Lower speed

- = lower noise level
- = lower power consumption
- = lower contamination level
- = no condensation in electrical components at low ambient temperatures

The FLKS-EC HYDAC Cooling series offers various possibilities for open-loop and closed-loop control. This means the right solution can be found for every application.

Available in the sizes:
FLKS-2EC, FLKS-3EC, FLKS-4EC,
FLKS-5EC, FLKS-8EC and FLKS-10EC.

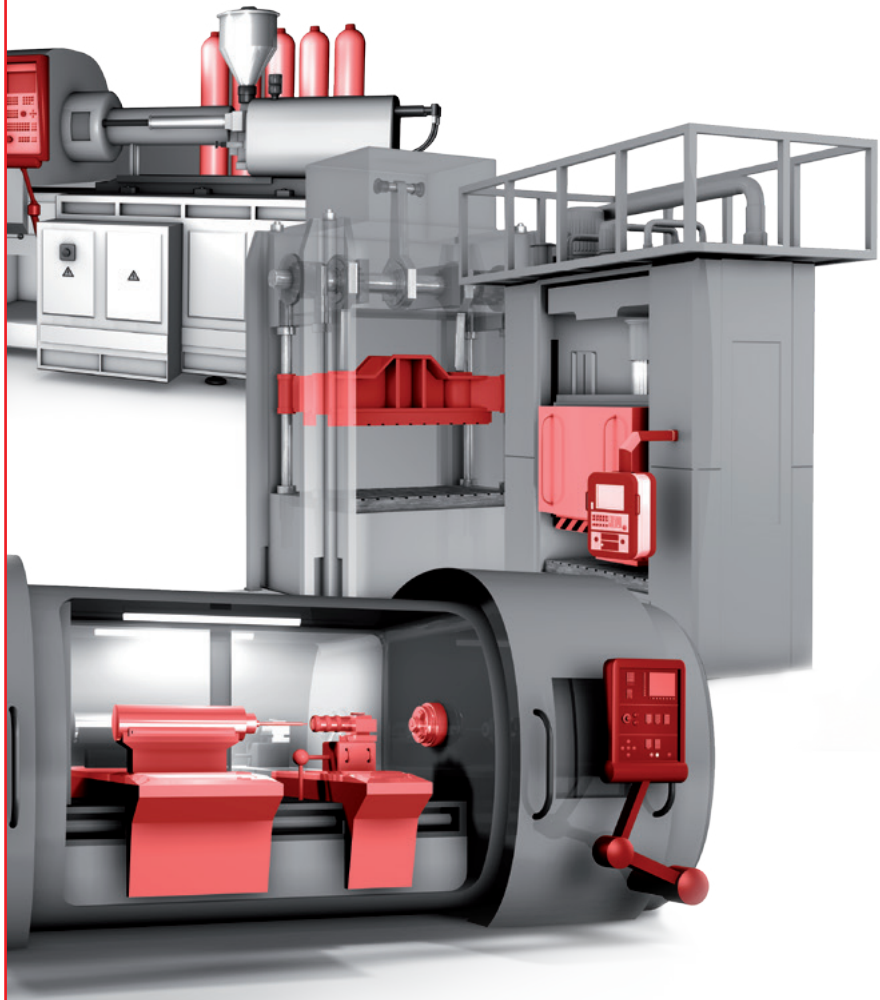

FLKS with constant speed (FLKS-xS)

The FLKS with AC fan drive operates with a constant speed and is therefore ideally suited to use in air-conditioned machine halls.

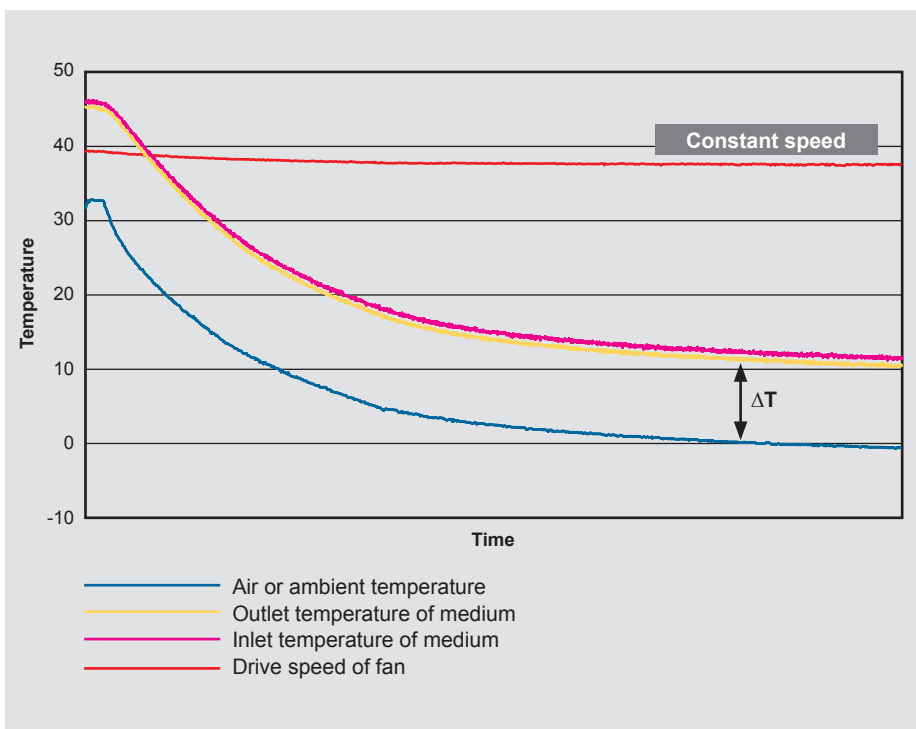

FLKS with AC fan drive:

Temperature response at decreasing ambient temperature and constant power input.

The medium's temperature curve follows the ambient temperature (at distance ΔT).

FLKS with open-loop speed control (FLKS-xEC5)

The FLKS with an EC fan drive is also equipped with a temperature sensor. The sensor's 0 – 10 V analogue signal is assigned a temperature range of 25 – 45 °C. An analogue signal is forwarded to the EC fan for open-loop control according to the measured fluid outlet temperature. The fan switches on at 1.5 V (= 28 °C) and reaches its maximum speed at 10 V (= 45 °C).

This FLKS is particularly suited to outdoor installation (e.g. for inverter cooling in cogeneration plants).

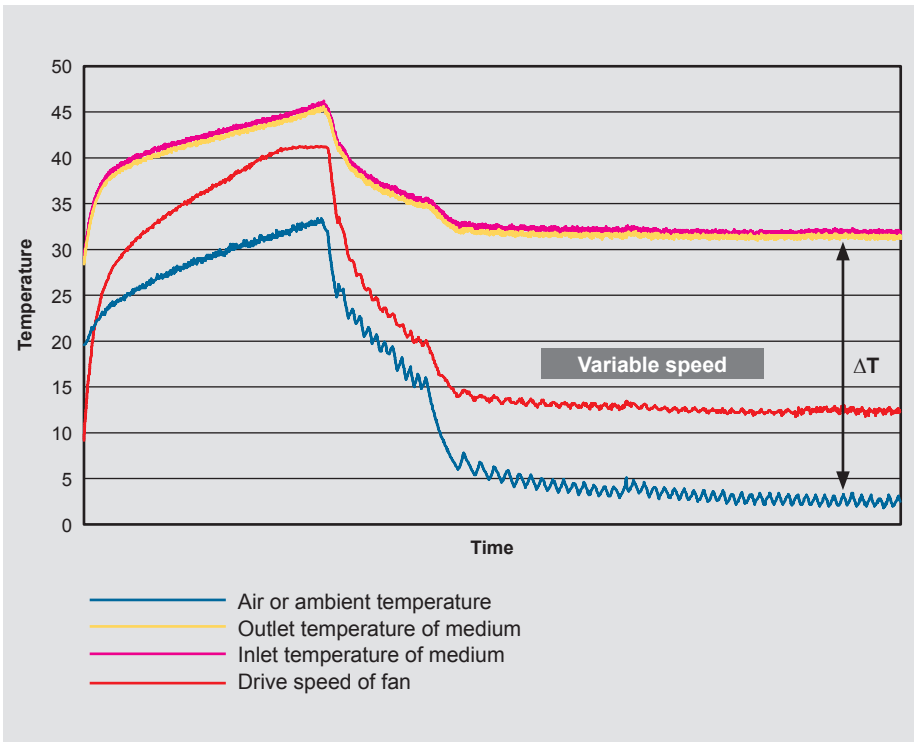
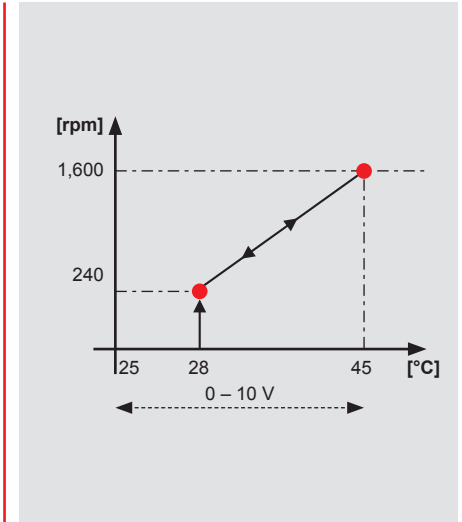
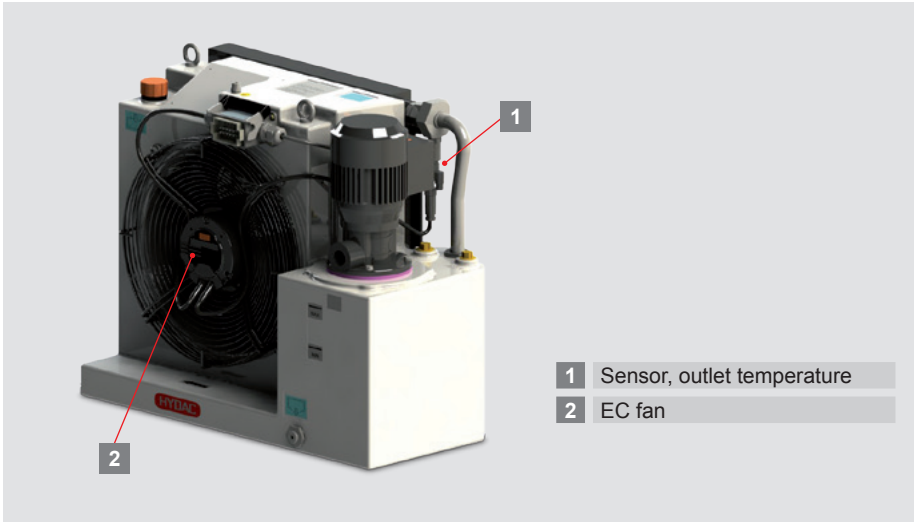

FLKS with open-loop speed control:

The fluid temperature is maintained at a temperature above 28 °C by the fan control, even when the ambient temperature falls to approx. 3 °C as is shown in the diagram (ΔT).

FLKS with closed-loop speed control (FLKS-xEC3)

Closed-loop control is when measurements are continually taken to determine to what extent the control variable corresponds with the guide value and – in contrast to open-loop control – a deviation automatically leads to adjustment of the control variable.

A temperature sensor measures the fluid outlet temperature (variable). This temperature is continuously compared with the guide value (ambient temperature + set differential ΔT). The PID controller continually adjusts the speed of the fan, in order to align the outlet temperature with the ambient temperature.

The FLKS with closed-loop speed control is mainly used in machine tools where high fluid temperature accuracy is required.

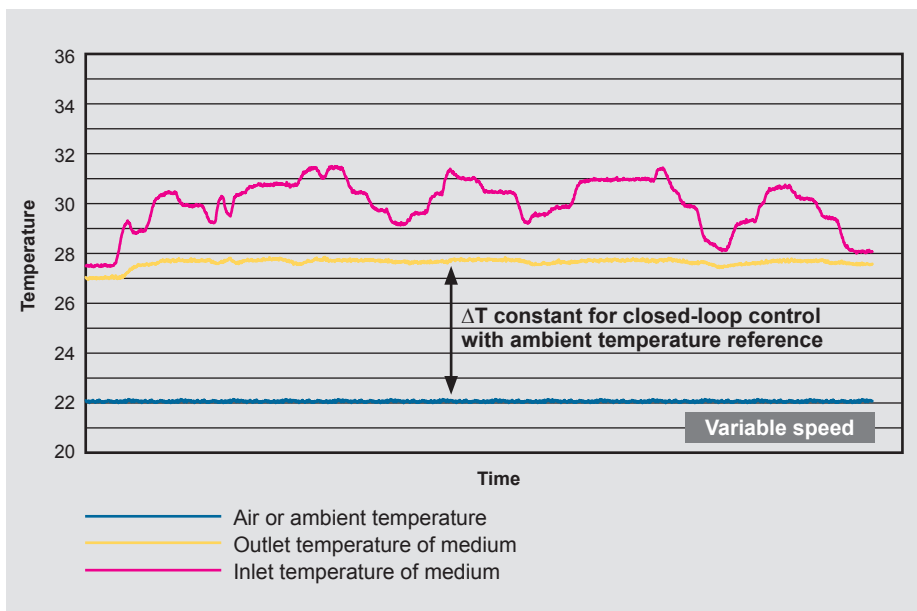
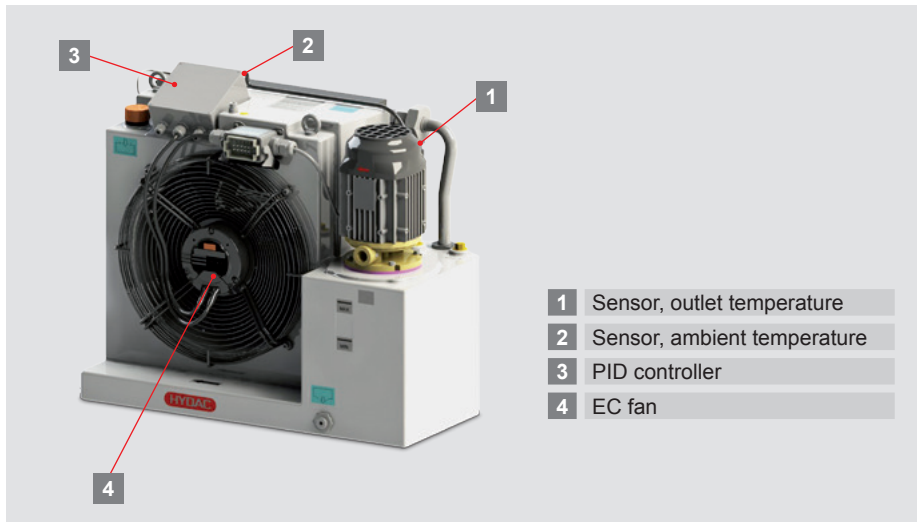

FLKS with closed-loop speed control:

Temperature trend with fluctuating power input.

The outlet temperature remains at a set differential (ΔT) above the ambient temperature regardless of the input temperature of the fluid (performance of the machine).

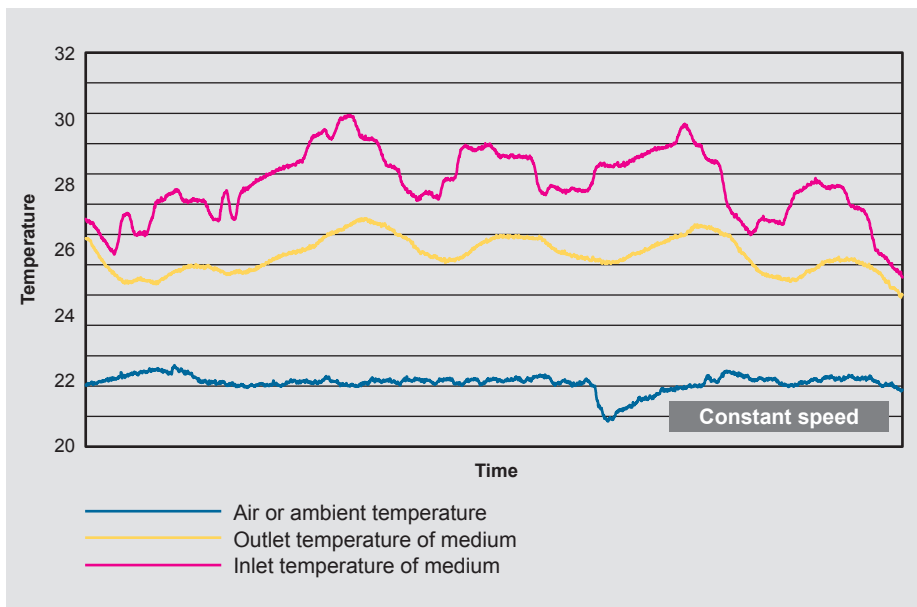

FLKS without closed-loop speed control:

Temperature trend with fluctuating power input.

The outlet temperature of the fluid fluctuates according to the power input. During machine downtimes it almost reduces to ambient temperature.

Note

Medium inlet and outlet are considered with regard to the cooling system, i.e. inlet from the consumer to the FLKS, outlet from the FLKS to the consumer.

The diagrams on the FLKS with constant speed and with open-loop speed control were created from tests in the cold chamber; the diagrams on closed-loop speed control were created from measuring results from practical tests on a machine tool.

Fluid / Air Cooling System (FLKS) design sheet

Project: _____

Contact: _____

Telephone: _____

E-mail: _____

Author: _____ Date: _____

Application: _____

Operating fluid: Water glycol % glycol: _____ %
 Mineral oil ISO VG _____
Viscosity at 10 °C: _____ cSt
Viscosity at 40 °C: _____ cSt

Operating fluid temperature: Input flow to consumer: _____ °C
Return flow to consumer:
(where required) _____ °C

Required cooling capacity: _____ kW

Flow rate of operating medium: _____ l/min

Pressure differential of operating medium: _____ bar At flow rate: _____ l/min

Max. permitted pressure _____ bar

Ambient temperature: min.: _____ °C max.: _____ °C

Altitude: _____ m above sea level

Place of installation: Indoors Outdoors

Cavity: Height: _____ mm Width: _____ mm Depth: _____ mm

Electrical data: Voltage: _____ V Frequency: _____ Hz

Temperature regulation of operating medium: None
 Open-loop speed control (FLKS-xEC5) e.g. for outdoors
 Closed-loop speed control (FLKS-xEC3)

Note

The information in this brochure relates to the operating conditions and applications described.

For applications and operating conditions not described, please contact the relevant technical department.

Subject to technical modifications.



HYDAC COOLING GMBH

INTERNATIONAL

Industriegebiet
66280 Sulzbach/Saar
Germany

Tel.: +49 6897 509-01
Fax: +49 6897 509-454

E-mail: cooling@hydac.com
Internet: www.hydac.com

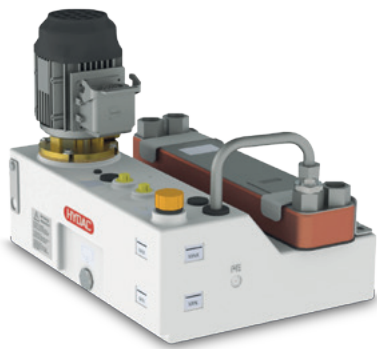

Fluid-Water Cooling Systems FWKS

Symbol

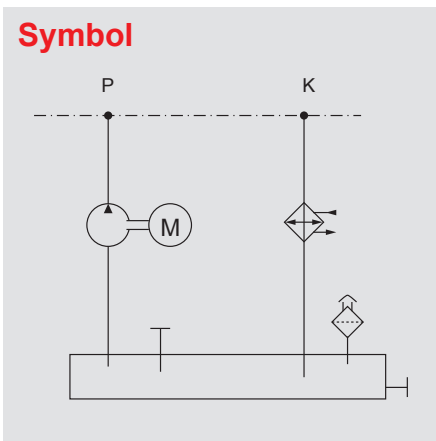

General

The **FWKS** is a compact fluid/water cooling system with a tank, circulating pump, plate heat exchanger and optional temperature control.

The FWKS is primarily used as an intermediate circuit. The advantage of an intermediate circuit is that the system or the parts being cooled only come into contact with the operating fluid and not the coolant water itself, which helps prevent the system from becoming contaminated or corroded.

Application Field

- Fluid-cooled drives:
Motor spindles, torque motors, servomotors, linear motors
- Inverter cooling
- Gearbox cooling and lubrication
- Bearing cooling
- Tool cooling

Operation Data

Cooling capacity	Max. 100 kW (depending on constraints)
Operating fluid	Water-glycol mixture (W): Potable water with 35 – 40 % ethylene glycol-based or propylene glycol-based antifreeze and anti-corrosion concentration Other fluids available upon request (e.g., mineral oil).
Permitted temperatures	Fluid temperature: max. 60 °C Ambient temperature: 0 – 45 °C
Output	Max. 100 l/min
Reservoir volume	Max. 70 l
Electrical connection	The motors are electrically connected using a terminal box or a heavy-duty plug.
Mounting position	Pump vertical
Accessories	<ul style="list-style-type: none"> ● Filling level switch ● Filling level and temperature switch ● Flow switch ● Temperature controller Combinations and other accessories available upon request.

Function

The pump conveys the operating fluid from the tank through the part of the consumer being cooled.

The operating fluid absorbs the heat and flows through the plate heat exchanger, where it is cooled by the coolant flowing in the opposite direction.

The operating fluid is then fed back to the tank.

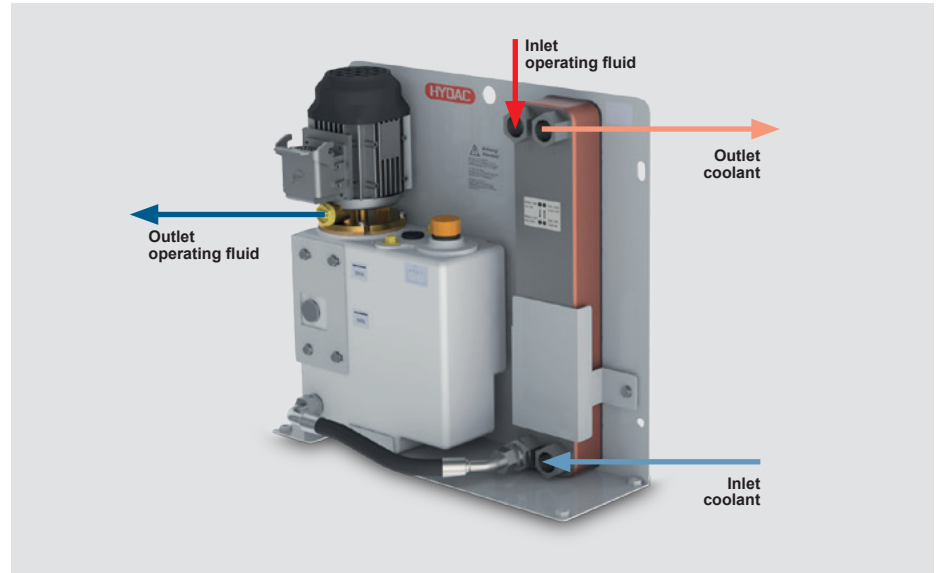

Control Options

In unregulated systems, the maximum quantity of coolant is always pumped through the plate heat exchanger regardless of the power input of the consumer. The FWKS with temperature control can change that by adding a valve that adjusts the amount of coolant to the requirements of the consumer. This means only the coolant that is needed to maintain the specified flow temperature is used. This is why regulated systems are particularly energy-efficient and conservative.

The FWKS series offers a number of control and regulating options.

This means the right solution can be found for any application.



Mechanical temperature control version

This version uses fixed value regulation.

The desired flow temperature is set manually. A temperature sensor in the tank measures the temperature of the operating fluid. The integrated proportional valve adjusts the amount of coolant to the power requirements of the consumer.

Application:

- Fixed value control to $\pm 3\text{ }^{\circ}\text{C}$
- Power cooling
- Protection against condensation
- No electricity required for controller



Electronic temperature control version

Sensors measure the fluid and air temperature, which is analyzed by the temperature controller. An integrated proportional valve adjusts the amount of coolant to the needs of the consumer.

This makes it possible to keep the fluid temperature the same as the ambient temperature (air or machine base temperature).

Application:

- Precision cooling to $\pm 0.5\text{ }^{\circ}\text{C}$
- Protection against condensation
- Fixed value setting or differential temperature regulation



FWKS-0/1.x



FWKS-2/1.x

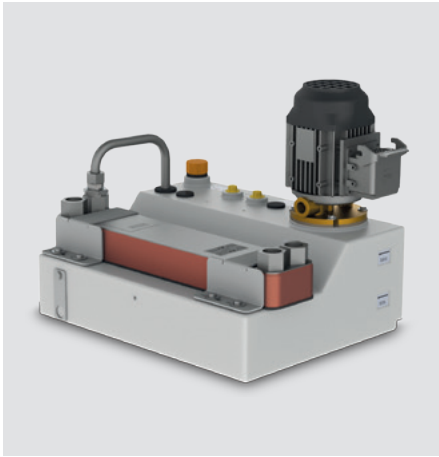

FWKS-2/2.x

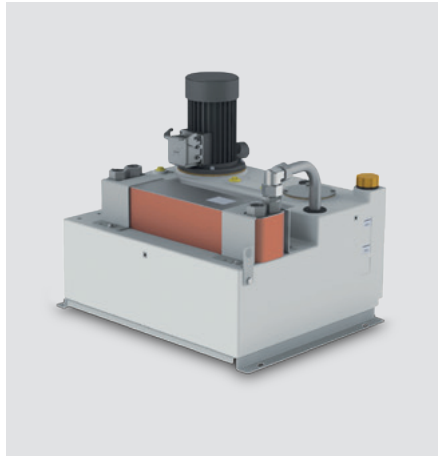

FWKS-3/2.x

	Cooling capacity*	Flow rate	Pressure range	Tank capacity	Dimensions H x W x D
FWKS-0/1.x	max. 10 kW	5 – 15 l/min	max. 3.5 bar	7.0 l	145 x 220 x 350 mm
FWKS-2/1.x	max. 20 kW	5 – 25 l/min	max. 5.5 bar	9.5 l	540 x 155 x 540 mm
FWKS-2/2.x	max. 30 kW	5 – 35 l/min	max. 5.5 bar	21.0 l	415 x 390 x 525 mm
FWKS-3/2.x	max. 100 kW	14 – 100 l/min	max. 5.5 bar	70.0 l	564 x 608 x 670 mm

* The maximum cooling capacity of the FWKS depends on several factors:

- the inlet temperature of the operating fluid and coolant
- the flow rate of the operating fluid and coolant
- the fluid used.

Specification Sheet Fluid/Water Cooling System (FWKS)

Project: _____
Contact: _____
Phone: _____
E-mail: _____
Date: _____ Author: _____

General

Required cooling capacity: _____ kW
Ambient temperature: min. _____ °C max. _____ °C
Site: _____
Cavity Height: _____ mm Width: _____ mm Depth: _____ mm
Electrical data: Voltage: _____ V Frequency: _____ Hz

Hot side

Operating fluid: Operating fluid: % glycol: _____ %
 Mineralöl ISO VG: _____
Viscosity at 10 °C: _____ cSt
Viscosity at 40 °C: _____ cSt

Operating fluid temperature: Flow to consumer: _____ °C
Return from consumer (if required): _____ °C
Flow rate: _____ l/min
Pressure differential: _____ bar
Max. permitted pressure: _____ bar

Cold side

Coolant supply: _____
Inlet temperature: min. _____ °C max. _____ °C
Guaranteed flow rate: _____ l/min
Available pressure differential: _____ bar

Control of operating fluid temperature:

- None
- Mechanical control
- Electronic control

Accessories:

- Filling level and temperature switch
- Filling level switch
- Flow switch
- _____

Other requirements:

Quantity required per year:

Note

The information in this brochure relates to the operating conditions.

For applications and operating conditions not described, please contact the relevant technical department.

Subject to technical modifications.



HYDAC COOLING GMBH

INTERNATIONAL

Industriegebiet
66280 Sulzbach/Saar
Deutschland

Tel.: +49 6897 509-01
Fax: +49 6897 509-454

E-mail: cooling@hydac.com
Internet: www.hydac.com

Chiller System RFCS

Symbol

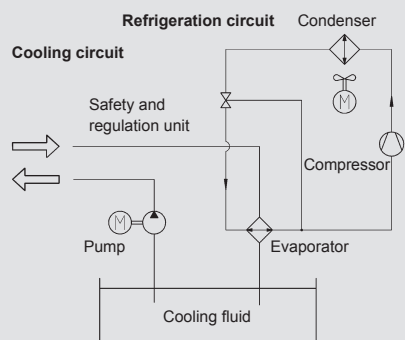

Application Field

- Machine tools
- Presses
- Milling machines
- Welding systems
- Laser cooling

Whether integrated into a machine or used as a separate auxiliary cooler or insertion cooler, the RFCS range of chillers will tackle any cooling task and guarantees quality for your products with utmost precision.

General

The RFCS cooling unit (chiller) is used to cool various liquids such as water, water glycol or oil down to the ambient temperature or below. The chiller system consists of refrigerator, pump, tank and controller and is able to set the temperature of the cooling media to a previously configured target value independently.

Product Features

- Fluid cooling system as separate auxiliary cooler or for integration into a machine
- Can be used for any cooling tasks
- Stand-alone control of the system by means of innovative controller design
- Condenser available as water-cooled or air-cooled variant
- Multiple cooling circuits
- Precise temperature control accuracies from ± 0.1 K
- Optional outdoor installation
- Think green – act green: energy-efficient mixer principle available as an option

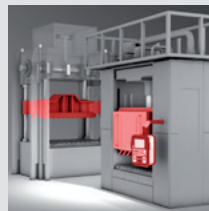

RFCS-G series



Separate auxiliary coolers with high capacities up to 160 kW for cooling tasks in the machine tool sector. Several units can be connected in parallel to expand the capacity as required.

RFCS-D series



Separate auxiliary cooler for cooling tasks in machine building (integration into the machine tool), capacities up to 7 kW

Temperature control / remote maintenance

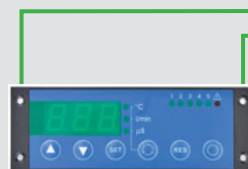

H.I.B control unit

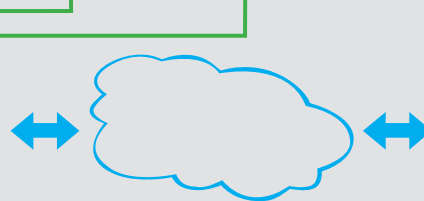

Operating Data

Series	Cooling power ¹⁾ [kW]	Condenser		Refrigerant			Pump capacity / flow rate	Electrical supply ¹⁾	Dimensions LxDxH [mm]	Weight [kg]
		air- cooled	water- cooled	DI ²⁾	IW ³⁾	Direct ⁴⁾ (without tank)				
G0	1.0	●	●	●	●	●	10 l/min @ 1.5 bar	230V - 50/60Hz	443 x 524 x 443	43
	1.5	●	●	●	●	●	10 l/min @ 1.5 bar	230V - 50/60Hz	443 x 524 x 443	45
	2.3	●	●	●	●	●	10 l/min @ 1.5 bar	230V - 50/60Hz	443 x 524 x 443	48
D2	3.3	●	●	●	●	●	15 l/min @ 2 bar	230V - 50/60Hz	480 x 420 x 800	80
	3.3	●	●	●	●	●	15 l/min @ 2 bar	400/440V - 50/60Hz	480 x 420 x 800	80
D3	4.5	●	●	●	●	●	15 l/min @ 2 bar	400/440V - 50/60Hz	595 x 555 x 1,131	130
	5.6	●	●	●	●	●	15 l/min @ 2 bar	400/440V - 50/60Hz	595 x 555 x 1,131	130
D4	7.5	●	●	●	●	●	40 l/min @ 3 bar	400/440V - 50/60Hz	601 x 601 x 1,361	160
G4	7.5	●	●	●	●	●	40 l/min @ 3 bar	400/440V - 50/60Hz	601 x 601 x 1,527	200
	9.5	●	●	●	●	●	40 l/min @ 3 bar	400/440V - 50/60Hz	601 x 601 x 1,527	250
G5	12	●	●	●	●	●	40 l/min @ 3 bar	400/440V - 50/60Hz	601 x 601 x 2,131	300
	15	●	●	●	●	●	40 l/min @ 3 bar	400/440V - 50/60Hz	601 x 601 x 2,131	300
G6	20	●	●	●	●	●	40 l/min @ 3 bar	400/440V - 50/60Hz	1,230 x 610 x 2,131	350
	26	●	●	●	●	●	40 l/min @ 3 bar	400/440V - 50/60Hz	1,230 x 610 x 2,131	380
	32	●	●	●	●	●	40 l/min @ 3 bar	400/440V - 50/60Hz	1,230 x 610 x 2,131	400
G7	40	●	●	●	●	●	90 l/min @ 3 bar	400/440V - 50/60Hz	1,860 x 1,000 x 2,134	1,000
	50	●	●	●	●	●	90 l/min @ 3 bar	400/440V - 50/60Hz	1,860 x 1,000 x 2,134	1,000
	60	●	●	●	●	●	90 l/min @ 3 bar	400/440V - 50/60Hz	1,860 x 1,000 x 2,134	1,000
	70	6)	●	●	●	●	150 l/min @ 3 bar	400/440V - 50/60Hz	1,860 x 1,000 x 2,021	750
	90	6)	●	●	●	●	150 l/min @ 3 bar	400/440V - 50/60Hz	1,860 x 1,000 x 2,021	770
	100	6)	●	●	●	●	150 l/min @ 3 bar	400/440V - 50/60Hz	1,860 x 1,000 x 2,021	780
	135	6)	●	●	●	●	250 l/min @ 3 bar	400/440V - 50/60Hz	1,860 x 1,000 x 2,021	800
155	6)	●	●	●	●	250 l/min @ 3 bar	400/440V - 50/60Hz	1,860 x 1,000 x 2,021	900	

1) Cooling capacity based on +35 °C ambient air / water to condenser and +20 °C process fluid supply temperature

2) DI = deionized water

3) IW = industrial water

4) Direct = Direct vaporization without refrigerant

5) Standard, additional voltages on request

6) Available as air-cooled variant with external condenser or heat exchanger



Accessories

- Higher capacity pumps available
- Several parallel circuits
- Ambient temperature-dependent control using separate temperature sensor
- Serial interface for system monitoring
- Filtration units for the refrigerant circuit
- Flow indicator and flow monitoring
- Extremely accurate control up to ± 0.1 K, standard ± 1.5 K
- Speed-controlled fans

Design

In the standard versions, the RFCS cooling units are designed complete with compressor, air cooled condenser, submersible pump and electronic control. Optionally available with energy-efficient mixer control where a small hysteresis is required.



G0



D2



D3



D4



G4



G5



G6



G7

Centralized Cooling Systems

RFCS water-chiller with heat exchanger and HY-ECOBOX

RFCS water chiller:

The RFCS is used to prepare cold water. Regardless of the particular ambient temperature, cold water can be provided in a wide range of capacity classes and fed to the customer application.

The unit is a water-cooled water chiller. The plate heat exchanger condenser transfers its process heat to a separate cooling-water circuit.

Heat exchanger:

RFCS cooling units with water-cooled condenser require a cooled water supply for heat removal. A heat exchanger is used when it is either not practical or not desirable to utilize mains water.

HY-ECOBOX:

The HY-ECOBOX is an optional module which contributes to improved energy saving: when the ambient temperature drops below a certain level, the cooling machine's active cooling is switched off. The system then operates in passive cooling mode, using the heat exchanger. This energy manager can therefore only be used in combination with a heat exchanger.

Advantages:

- Saves resources, as no water is used
- High energy-saving potential thanks to the HY-ECOBOX*
- The RFCS transfers no heat into the building

* ECOBOX: optional accessory for passive free cooling operation

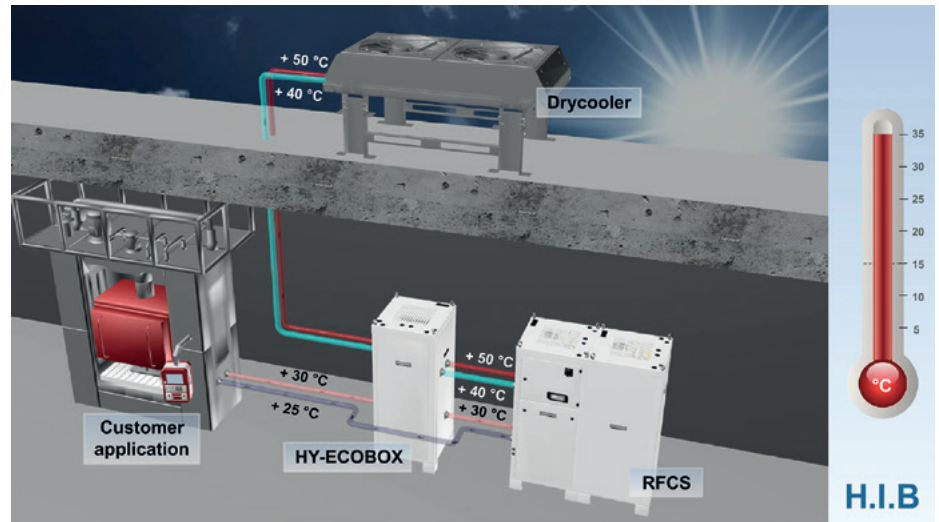

Functioning at high external temperatures

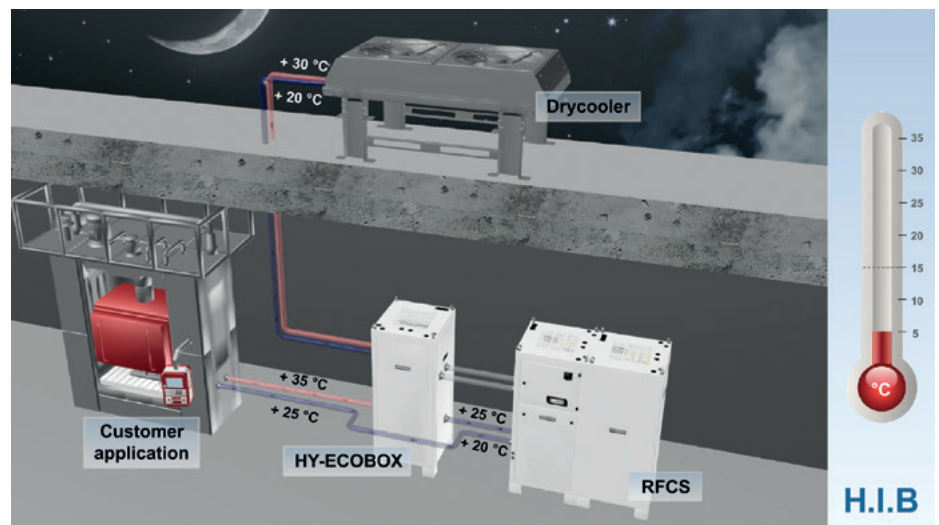

Functioning at low external temperatures

From the prototype to series production

- **Planning and advice** from our specialists on site.
You provide the task, we supply the solution.
- Our own **development centre** produces market-driven, energy-efficient and cutting-edge solutions, to stay one step ahead of the “state of the art”.
- The coolers are **produced** in the Bavarian town of Friedberg and rightly deserve the “Made in Germany” seal of quality!
- In order to provide **quality** that is consistently very good, all equipment must undergo a function and performance test.
- For **service** you can call on an international network of service engineers. Consultation and service – with global reach.

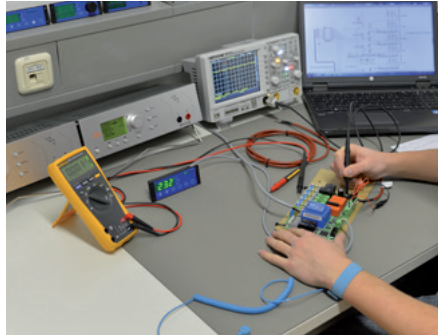

Design Data Sheet, RFCS Cooling Unit

Project: _____
Contact: _____
Telephone: _____
E-mail: _____
Date _____ Created by _____

Application

Active cooling (RFCS): air-cooled
 water-cooled

Installation site: Indoors Outdoors

Series/housing*: D G

Technical data

Required cooling capacity: _____ kW
at _____ °C operating temperature
and _____ °C ambient temperature

Relative humidity: _____ %RH

Operating temperature adjustable from: _____ °C to _____ °C

Supply voltage: _____ V _____ Ph _____ Hz

Temperature accuracy and control type

Control accuracy: ±0.1 K ±0.5 K ±1.5 K

Control type: Fixed value Controlled by ambient temperature

Cooling fluid/refrigerant

Cooling fluids: Water glycol DI water Mineral oil

% glycol: _____ %
Conductance: _____ µS/cm
ISO _____ / _____ cSt

Pump specifications

Flow rate: _____ l/min

Operating pressure: _____ bar

Connection system, cooling circuit: _____ " internal thread

Additional information on water-cooled RFCS: external cooling water supply

Inlet temperature: min. _____ °C max. _____ °C

Guaranteed water quantity: _____ l/min

Pressure p: min. _____ bar max. _____ bar

Cooling water supply: _____ e.g. well water, fresh water

Equipment

Comment

- Paint (standard RAL 7035): _____
- Tank heating _____
- Flow monitoring _____
- Flow indicator _____
- Filter for cooling fluid (particle filter) Filtration rating: _____ μm
- Controlled fan _____
- Air filter monitoring _____
- DI cartridges _____
- Conductance monitoring _____
- Conductance control Switching point: _____ $\mu\text{S/cm}$

Electric system

Comment

- Cooler plug connector with mains filter _____
- Power adaptor (internal 24 V supply) _____
- Power supply cable _____
- Main switch _____
- Remote start (potential-free contact) _____
- Supply / elec. connection Design:
(e.g. industrial connector, multi-pin) _____
- Transformer for special voltage _____
- Data interface (e.g. RS485) _____
- Interface specification _____

Other accessories: _____

Comments: _____

Annual unit qty.: _____

* Series/housing:

The D basic housing is equipped with a horizontal condenser, making for flexible air routing/setup as access to the insides of the devices only needs to be possible from one side. The G basic housing is fitted with an upright condenser to provide compact installation space requirements even at higher capacity levels.

Note

The information in this brochure relates to the operating conditions and applications described.

For applications and operating conditions not described, please contact the relevant technical department.

Subject to technical modifications and corrections.

H.I.B HYDAC INTERNATIONAL

H.I.B Systemtechnik GmbH
Winterbrückenweg 30
86316 Friedberg-Derching
Germany
Tel.: +49 821/747 71-4
Fax: +49 821/747 71-5594
E-mail: info@h-i-b.de
Internet: www.h-i-b.de

HYDAC COOLING GMBH
Industriegebiet
66280 Sulzbach / Saar
Germany
Tel.: +49 6897/509-01
Fax: +49 6897/509-454
E-mail: cooling@hydac.com
Internet: www.hydac.com

Cabinet Cooling HCC



General

The HCC control cabinet cooler system is flexible in its installation and designed to cool control cabinets. Special heat exchanger designs ensure energy-efficient operation and a high level of operating reliability.

Regardless of the version used, whether air/air, air/water or refrigeration, the HCC series ensures optimal conditions and improved service life for your electronic components.

Product Features

- Control cabinet cooler for roof installation or wall/door mounting
- Cooling capacities from 0.1 to 15 kW
- For all cooling applications in switchgears or control cabinets
- Stand-alone control of the system by means of innovative controller design
- Active cooler with compressor and passive cooler with air/air or air/water available

Application Field

- Machine tools
- Presses
- Milling machines
- Welding systems
- Laser cooling

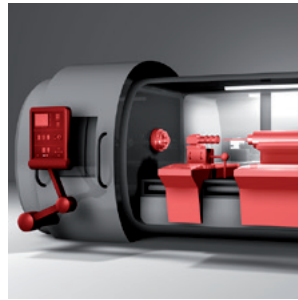

Machine tools

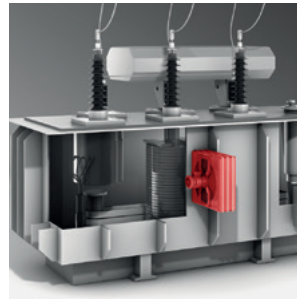

Thermal power plants

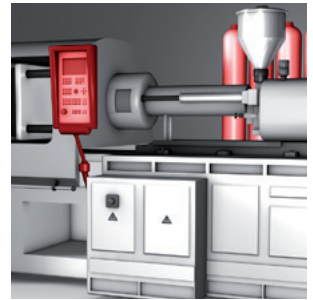

Plastic injection machines

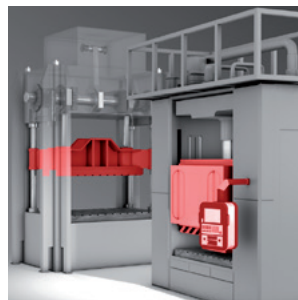

Presses

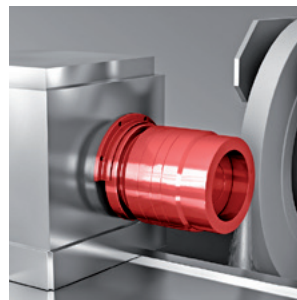

Lathes



Automotive Industry

Technical Data

Active coolers

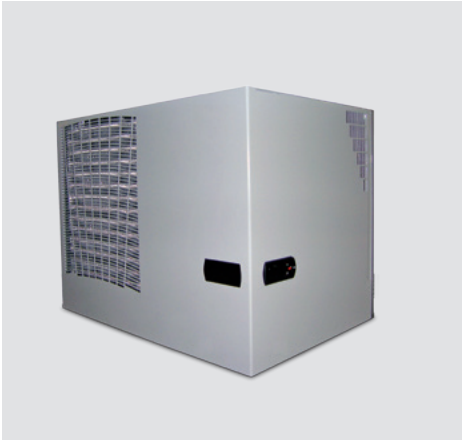

HCC-T-C



HCC-S-C

HCC-T-C top-mounted – refrigeration coolers

	Electrical supply [V - Ph - Hz]	Cooling capacity [W]	Dimensions height x width x depth [mm]	Maximum current consumption [A]	Starting current [A]	Power consumption [W]	Temperature setting range [°C]	Ambient temperature [°C]	Weight [kg]
HCC-T-C-03	230 - 1 - 50/60 115 - 1 - 60	330 270	180 x 476 x 324	1.4 2.8	5.0 10.0	240	25 - 45	20 - 55	17.0 18.0
HCC-T-C-09	230 - 1 - 50/60 115 - 1 - 60 400 - 2 - 50 460 - 2 - 60	900	335 x 600 x 325	3.2 8.0 1.8 1.8	15.0 15.0 31.0 31.0	630	25 - 45	20 - 55	31.5 31.5 33.0 33.0
HCC-T-C-14	230 - 1 - 50/60 115 - 1 - 60 400 - 2 - 50 460 - 2 - 60	1,400	450 x 600 x 400	5.2 10.0 2.8 2.8	17.0 34.0 31.0 31.0	950	25 - 45	20 - 55	48.0 48.0 53.0 53.0
HCC-T-C-20	230 - 1 - 50/60 400 - 2 - 50 460 - 2 - 60	2,000	450 x 600 x 400	5.7 3.3 3.3	22.0 31.0 31.0	1,200	25 - 45	20 - 55	51.5 58.5 58.5
HCC-T-C-28	230 - 1 - 50/60 400 - 3 - 50 460 - 3 - 60	2,700	480 x 800 x 450	7.0 2.3 2.3	38.0 16.0 16.0	1,580 1,580 1,580	25 - 45	20 - 55	74.5 76.5 76.5

Accessories: Fitted with electronic temperature regulator (except HCC-T-C-03)

Optional: Special colouring, UL design and stainless-steel housing available on request

HCC-S-C side-mounted – refrigeration cooler

	Electrical supply [V - Ph - Hz]	Cooling capacity [W]	Dimensions height x width x depth [mm]	Maximum current consumption [A]	Starting current [A]	Power consumption [W]	Temperature setting range [°C]	Ambient temperature [°C]	Weight [kg]
HCC-S-C-03	230-1-50/60 115-1-60	360-380 380	443 x 324 x 206	1.3 / 1.4 2.9	9.8 18.0	190 - 220 220	+25 / +45	+20 / +55	17.0
HCC-S-C-05	230-1-50/60	550-580	642 x 313 x 223	1.35 / 1.5	15.0	310 - 340	+25 / +45	+20 / +55	23.0
	400-2-50	500		0.7	15.0	310 - 340	+25 / +45		26.0
	460-2-60	550		0.75	15.0	310 - 340	+25 / +45		23.0
	48 V DC	500		5.7	-	300	+25 / +35		23.0
	115-1-60	580		4.7	17.0	340	+25 / +45		23.0
HCC-S-C-07S	230-1-50/60	800-850	550 x 279 x 286	1.9 / 2.0	9.6	450 - 490	+25 / +45	+20 / +55	20.0
HCC-S-C-08	230-1-50/60	850-900	642 x 313 x 223	2.6 / 2.7	20.0	420 - 600	+25 / +45	+20 / +55	27.0
	400-2-50	800-850		1.0	20.0	420 - 600			30.0
	400-2-60	800-850		1.4	20.0	420 - 600			30.0
	115-1-60	900		7.2	28.0	600			27.0
HCC-S-C-11	230-1-50/60	1,100-1,150	912 x 410 x 248	3.1 / 3.4	18.0	510 - 650	+25 / +45	+20 / +55	44.0
	400-2-50	1,050-1,100		1.7 / 1.8	30.0	510 - 650			50.0
	460-2-60	1,050-1,100		1.7 / 1.8	30.0	510 - 650			50.0
	115-1-60	1,150		7.5	34.0	650			44.0
HCC-S-C-15	230-1-50/60	1,500-1,600	912 x 410 x 248	3.9 / 4.3	28.0	750 - 825	+25 / +45	+20 / +55	46.0
	400-2-50	1,400-1,500		2.5 / 2.6	110.0	750 - 825			53.0
	460-2-60	1,400-1,500		2.5 / 2.6	100.0	750 - 825			53.0
	115-1-60	1,600		9.4	50.0	825			46.0
HCC-S-C-15S	230-1-50/60	1,500-1,600	950 x 400 x 304	3.9 / 4.3	28.0	750 - 825	+25 / +45	+20 / +55	65.0
	400-3-50	1,400-1,500		2.0 / 2.2	20.0	810 - 890			
	460-3-60	1,400-1,500		2.0 / 2.2	20.0	810 - 890			
HCC-S-C-20	230-1-50/60	2,100-2,200	1,005 x 409 x 263	4.8 / 5.5	34.0	1,120 - 1,240	+25 / +45	+20 / +55	48.0
	400-3-50	2,000-2,100		2.5 / 2.7	22.0	1,100 - 1,200			
	460-3-60	2,000-2,100		2.5 / 2.7	22.0	1,100 - 1,200			
	115-1-60	2,200			60.0	1,240			
HCC-S-C-25S	230-1-50/60	2,550-2,750	1,580 x 400 x 305	4.2 / 5.2	18.0	1,100 - 1,280	+25 / +45	+20 / +55	65.0
	400-3-50	2,400-2,600		3.0 / 3.2	22.0	1,230 - 1,380			68.0
	460-3-60	2,400-2,600		3.0 / 3.2	22.0	1,230 - 1,380			68.0
HCC-S-C-30	230-1-50/60	3,000-3,150	1,217 x 511 x 347	5.0 / 5.5	35.0	1,370 - 1,510	+25 / +45	+20 / +55	75.0
	400-3-50	2,850-3,000		2.7 / 3.0	19.0	1,370 - 1,510			80.0
	460-3-60	2,850-3,000		2.7 / 3.0	19.0	1,370 - 1,510			80.0
HCC-S-C-40	230-1-50/60	4,000-4,100	1,217 x 511 x 347	8.2 / 9.4	42.0	1,730 - 1,950	+25 / +45	+20 / +55	80.0
	400-3-50	3,950-4,050		2.9 / 4.0	25.0	1,730 - 1,950			85.0
	460-3-60	3,950-4,050		2.9 / 4.0	25.0	1,730 - 1,950			85.0
HCC-S-C-60	400-3-50	5,600-5,950	1,405 x 554 x 404	4.2 / 5.7	53.0	2,670 - 3,600	+25 / +45	+20 / +55	100.0
	460-3-60	5,600-5,950		4.2 / 5.7		2,670 - 3,600			

Accessories: Fitted with electronic temperature regulator

Optional: Special colouring, UL design and stainless-steel housing available on request

Example installation, active cooler

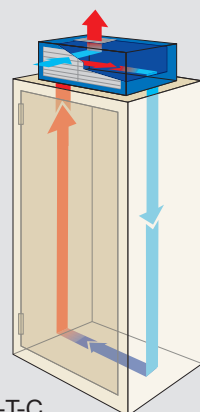

HCC-T-C

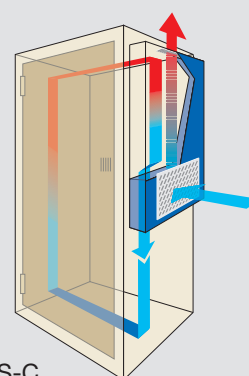

HCC-S-C

Technical Data

Passive coolers

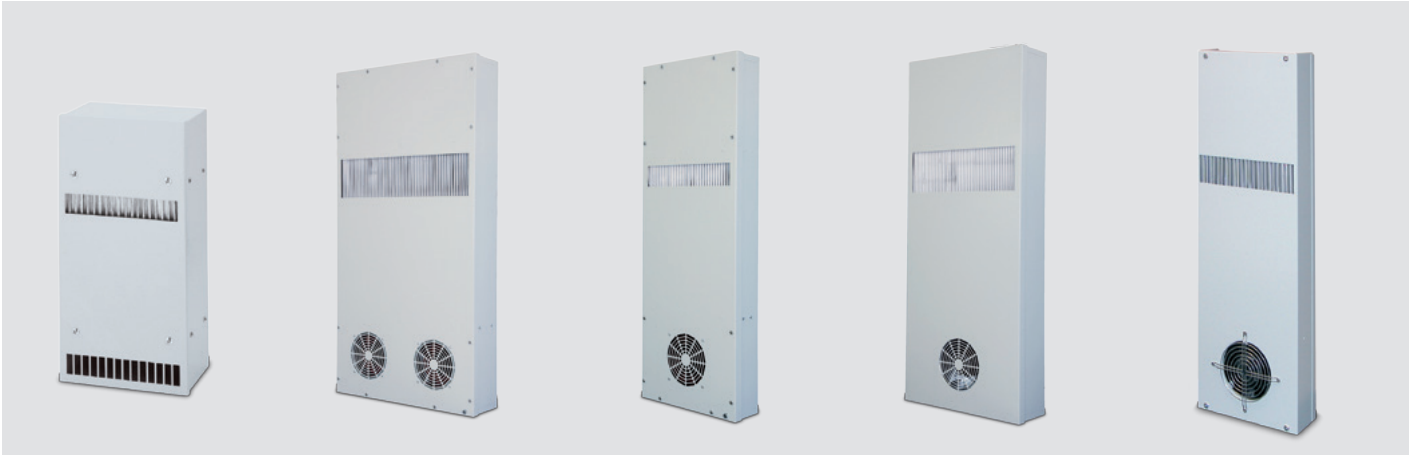

HCC-S-AA



HCC-S-AW



HCC-T-AW

HCC-S-AA side-mounted – air/air cooler

	Electrical supply [V - Ph - Hz]	Specific capacity in watt/K	Dimensions height x width x depth [mm]	Current consumption (A)	Power consumption [W]	Temperature setting range [°C]	Ambient temperature [°C]	Weight [kg]
HCC-S-AA-16	230 -1- 50/60 115 -1- 60	16	410 x 204 x 109	0.60	64 40	-5 / +55	-5 / +55	4.6
HCC-S-AA-30	48 V DC	30	780 x 255 x 90	4.30	210	-5 / +55	-20 / +55	15.0
HCC-S-AA-35	230 -1- 50/60 230 -1- 60 115 -1- 60	35	780 x 254 x 90	0.72 0.80 1.10	160 150 180	-5 / +55	-5 / +55	7.5
HCC-S-AA-50	230 -1- 50/60 230 -1- 60 115 -1- 60	50	780 x 312 x 90	0.72 0.80 1.40	160 150 180	-5 / +55	-5 / +55	9.5
HCC-S-AA-60	230 -1- 50/60 48 V DC 115 -1- 60	60	1,030 x 365 x 110	0.76 / 0.80 4.30 2.20	170 - 180 210 265	-5 / +55	-20 / +55 -20 / +55 -40 / +55	16.0
HCC-S-AA-80	230 -1- 50/60 230 -1- 60 115 -1- 60	80	1,250 x 311 x 108	1.00 1.30 2.30	170 180 230	-5 / +55	-5 / +55	20.0

Optional: Special colouring, UL design and stainless-steel housing available on request

HCC-S-AW side-mounted – air/water cooler

	Electrical supply [V - Ph - Hz]	Specific capacity T = 25 K	Dimensions height x width x depth [mm]	Current consumption (A)	Power consumption [W]	Water flow rate [l/h]	Max. water pressure [kPa]	Pressure loss, water side [kPa]	Temperature range, cabinet side [°C]	Weight [kg]
HCC-S-AW-06	230-1-50/60 230-1-60 115-1-60	870	403 x 306 x 113	0.28 / 0.24 0.50 0.50	33 / 36 24 24	150	500	2	+10 / +50 0.2 0.2	7.0
HCC-S-AW-15	230-1-50/60 230-1-60 115-1-60	2,200	916 x 402 x 206	0.26 / 0.34 0.80 0.80	58 / 75 75 90	150	1,000	30	+10 / +50 0.2 0.2	21.0
HCC-S-AW-25	230-1-50/60 230-1-60 115-1-60	3,100	916 x 402 x 206	0.38 / 0.40 1.00 1.00	85 / 90 90 115	500	1,000	63	+10 / +50 0.2 0.2	22.0
HCC-S-AW-50	230-1-50/60 230-1-60 115-1-60	6,700	916 x 402 x 206	0.70 / 0.95 1.30 2.00	115 / 215 285 155	860	1,000	40	+10 / +50 +10 / +50 +10 / +50	39.0

Optional: Thermostat with solenoid valve, special colouring, UL design and stainless-steel housing available on request

HCC-T-AW top-mounted installation – air/water coolers

	Power supply [V - Ph - Hz]	Specific capacity T = 10 °C	Dimensions height x width x depth [mm]	Maximum current consumption [A]	Power consumption [W]	Temperature setting range [°C]	Water temperature °C	Weight [kg]
HCC-T-AW-15H	230-1-50/60	2,200	200 x 800 x 400	0.26 / 0.34	58 / 75	+10 / +50	+10 / +30	30.0
HCC-T-AW-50H	230-1-50/60	6,700	255 x 905 x 509	0.70 / 0.95	155 / 215	+10 / +50	+10 / +30	39.0

Optional: Special colouring and stainless-steel housing available on request

All units are designed for indoor applications only.
Solutions for outdoor applications are available on request!

Example installation, passive cooler

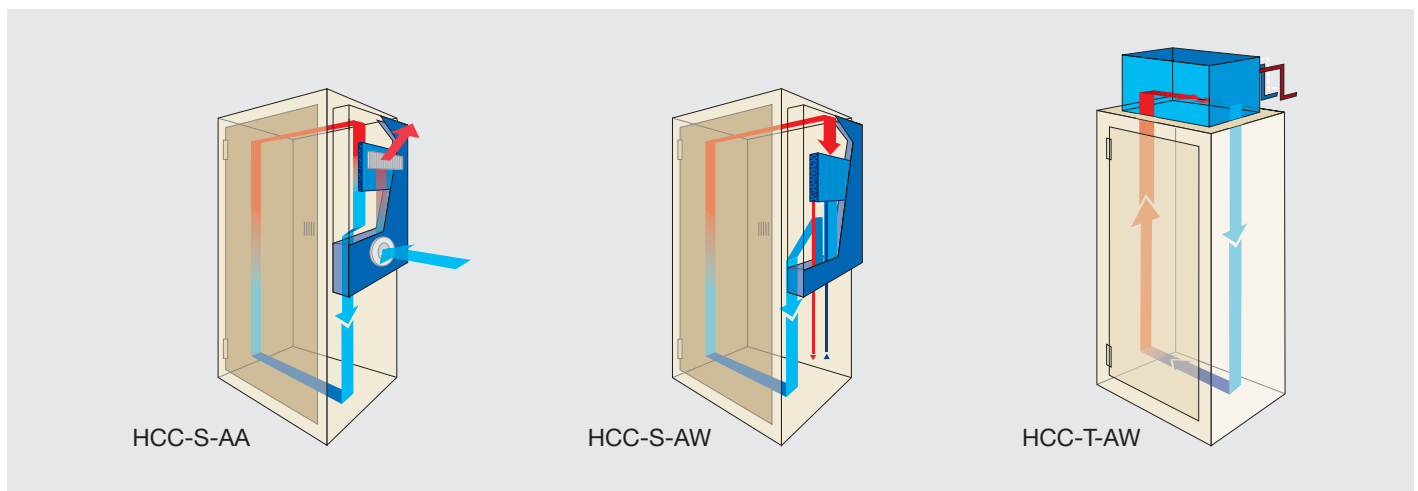

From the prototype to series production

- **Planning and advice** from our specialists on site.
You provide the task, we supply the solution.
- Our own **development centre** produces market-driven, energy-efficient and cutting-edge solutions, to stay one step ahead of the “state of the art”.
- In order to provide **quality** that is consistently very good, all equipment must undergo a function and performance test.
- For **service** you can call on an international network of service engineers.
Consultation and service – with global reach.

Note

The information in this brochure relates to the operating conditions and applications described.

For applications and operating conditions not described, please contact the relevant technical department.

Subject to technical modifications and corrections.

H.I.B HYDAC INTERNATIONAL

H.I.B Systemtechnik GmbH
Winterbrückenweg 30
86316 Friedberg-Derching
Germany
Tel.: +49 821/747 71-4
Fax: +49 821/747 71-5594
E-mail: info@h-i-b.de
Internet: www.h-i-b.de

HYDAC COOLING GMBH
Industriegebiet
66280 Sulzbach / Saar
Germany
Tel.: +49 6897/509-01
Fax: +49 6897/509-454
E-mail: cooling@hydac.com
Internet: www.hydac.com

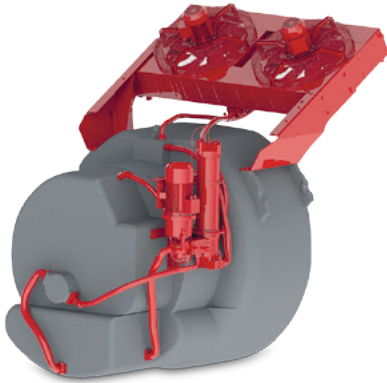

Gearbox Cooling Systems

HYDAC gearbox lubrication coolers are compact systems for application-specific oil conditioning:

Filtration

In the main flow:

Combined filter consisting of a fine filter with bypass valve and a coarse filter

- High contamination retention capacity, low differential pressure
- High retention rates with excellent β_{sx} value stability

Offline:

With compact offline flow filter specially designed for removing products of oil ageing, solid particles and water (optional / customisable).

Cooling

Efficient and compact air cooling with optional

- Integrated thermal bypass (IBT)
- Hot climate/cold climate versions
- Fixings as part of the housing

Also available with a plate heat exchanger.

Circulation

For supplying the lubrication points

- Electric and/or mechanical pump
- Clogging indicator on the filter
- Option to have MCS in the main flow to detect metallic particles
- Gearbox inlet block with pressure and temperature monitoring available

Application Field

Large gearboxes between 100 kW and several MW e.g. in

- Wind power
- Cable winches
- Vertical milling machines

Specification Sheet for Gearbox Cooling Systems

Project: _____
Contact: _____
Telephone: _____
E-mail: _____

Application

Gearbox designation: _____
Gearbox manufacturer: _____
Type/size: _____ MW
Heat load/required dissipation: _____ kW
Oil: _____
Max. permissible oil sump temperature: _____ °C (typically +70°C)
Oil volume in the gearbox: _____ l
Desired flow rate:
 Electric pump _____ l/min
 Mechanical pump _____ l/min _____
Start temperature of the pump: _____ °C (typically 0 .. +5°C)
Cooling method: Oil/air cooler Plate heat exchanger

Ambient conditions

Installation: Onshore Near shore Offshore

Max. humidity: _____ %RH

Air temperature

Cooler intake

Outside air

During operation:	max.	_____ °C	_____ °C	HYDAC standard: +40°C
	min.	_____ °C	_____ °C	HYDAC standard: -10°C Cold Climate: -30°C
At standstill:	max.	_____ °C	_____ °C	HYDAC standard: +50°C
	min.	_____ °C	_____ °C	HYDAC standard: -20°C Cold Climate: -40°C

Location (country): _____

Altitude: _____ m above sea level

Electrical data

Voltage: 50 Hz: _____ V 60 Hz: _____ V

- Sensors:
- Metallic Contamination Sensor (MCS)
 - Temperature sensor (PT100)
 - Pressure sensor (HDA 4345/EDS 3346)
 - Other _____

Documents

Specification available: _____ Version no. _____

Drawing of gearbox: 2D no./version _____ 3D no./version _____

Number of items

Prototype required? Quantity _____ Period of time _____

Expected quantity required per year 1st year _____ 2nd year _____ 3rd year _____

- Items supplied:
- Oil circulator
 - Cooler
 - Hoses
 - Steel frame
 - Sensors

Are additional cooling systems required?

Generator: Air cooler Water cooler

Converter: Air cooler Water cooler

Transformer: Air cooler Water cooler

Others: _____

Comments

Note

The information in this brochure relates to the operating conditions and applications described.

For applications and operating conditions not described, please contact the relevant technical department.

Subject to technical modifications and corrections.



HYDAC COOLING GMBH

INTERNATIONAL

Industriegebiet
66280 Sulzbach/Saar
Germany

Tel.: +49 6897 509-01
Fax: +49 6897 509-454

E-mail: cooling@hydac.com
Internet: www.hydac.com

Water Glycol Circuits WGK



HYDAC WGK coolers are designed to maintain a consistent coolant temperature in fluid cooled systems.

This is achieved by means of heating, mixing and cooling.

Equipment options:

- Closed water glycol circuit (WGK) with pump, expansion tank, mixing valve, screw-in heating device and sensors (pressure, temperature)
- Water/air cooler or plate heat exchanger

Benefits:

- Stops condensation from forming
- No temperature shocks when turning on the air cooler at low air temperatures
- By connecting additional fans, the cooling capacity can be adjusted as required

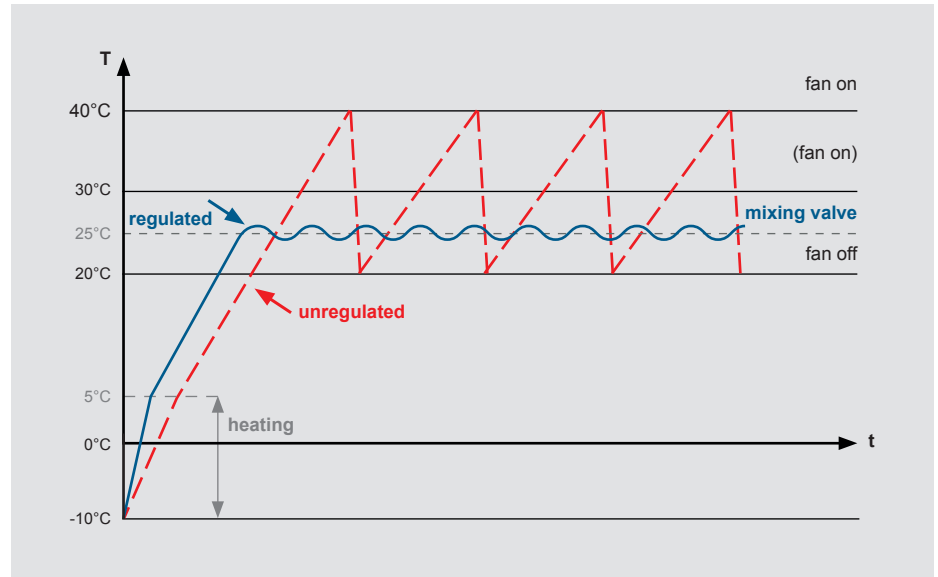

Application Field

- Converters
- Generators
- Transformers
- Inverters

Specification Sheet for Water Glycol Circuits

Project: _____
Contact: _____
Telephone: _____
E-mail: _____
Date: _____ Completed by: _____

Wind turbine/photovoltaic system

Manufacturer: _____
Wind turbine: With gearbox Direct drive
Location (country): _____
Component being cooled: Converter Generator _____
Heat load/required dissipation: _____ kW

Design

Cooler installation location: Inside Outside
Max. water glycol inlet temperature: _____ °C of component being cooled
Total water glycol volume: _____ ltr in the component being cooled
Pressure loss of the component being cooled during flow: _____ bar at _____ l/min
Pressure relief max. _____ bar

Ambient conditions

Installation: Onshore Near shore Offshore
Max. humidity: _____ %RH
Altitude: _____ m above sea level

Ambient temperature

During operation: max. _____ °C HYDAC standard: +40°C
min. _____ °C HYDAC standard: -10°C
Cold Climate version: -30°C
At standstill: max. _____ °C HYDAC standard: +50°C
min. _____ °C HYDAC standard: -20°C
Cold Climate version: -40°C

Electrical data

Voltage: 50 Hz: _____ V 60 Hz: _____ V
Rated power: _____ MW

Ports

Ports on the component
being cooled:

Planned hose
length/nominal diameter:

Converter cooling system

Required heating capacity: _____ kW

Mixing valve: Yes No

Additional requirements

Are additional cooling systems required?

Gearbox: _____

Others: _____

Comments

Note

The information in this brochure relates to the operating conditions and applications described.

For applications and operating conditions not described, please contact the relevant technical department.

Subject to technical modifications and corrections.



HYDAC COOLING GMBH

INTERNATIONAL

Industriegebiet
66280 Sulzbach/Saar
Germany

Tel.: +49 6897 509-01
Fax: +49 6897 509-454

E-mail: cooling@hydac.com
Internet: www.hydac.com

Buyer's Guide

Order Direct by Phone, Fax or Email

The products listed here are preferred sizes:

- Single units are available ex stock or within 10 days
- Easy to order using Part Number
- Over 40 years' experience in hydraulics

Tel.: +49 6897 509-01
 Fax: +49 6897 509-1009
 E-mail: info@hydac.com

Your nearest contact can be found on the "Company/Locations" page of our website: www.hydac.com



AC-LN

- Axial fan
- For oils and water glycol
- Dynamic operating pressure: 16 bar

Part No.	Designation	Cooling capacity Mineral oil*	Cooling capacity Water glycol*
3860765	AC-LN 2S/1.0/F/A/1	5.0 kW	5.3 kW
3860382	AC-LN 3S/1.0/F/A/1	9.0 kW	9.3 kW
3860090	AC-LN 4S/1.0/F/A/1	15.5 kW	17.3 kW
3859080	AC-LN 6S/1.0/F/A/1	25.0 kW	31.3 kW
3686305	AC-LN 8S/1.0/F/B/1	55.0 kW	57.3 kW

* At $\Delta T = +40\text{ }^{\circ}\text{C}$ and a flow rate of 120 l/min

For further information, see brochure no. 5.816 (AC-LN 1-7) and 5.814 (AC-LN 8-14).



OSCA

- Radial fan
- For oils
- With screw pump

Part No.	Designation	Cooling capacity Mineral oil*	Pump flow rate
3926219	OSCA 0S/10/1.0/M/A/1	1.8 kW	15 l/min
3768893	OSCA 1L/10/1.0/M/A/1	3.7 kW	10 l/min
3684999	OSCA 1S/10/1.0/M/A/1	4.3 kW	15 l/min
3647770	OSCA 2L/28/5.0/M/A/1	7.0 kW	28 l/min
3647749	OSCA 2S/28/5.0/M/A/1	9.2 kW	40 l/min
3672255	OSCA 3S/28/5.0/M/A/1	15.0 kW	40 l/min

* At $\Delta T = +40\text{ }^{\circ}\text{C}$

For further information, see brochure no. 5.811 (OSCA / OSCAF 1-3).



Brazed Plate Heat Exchangers

- Stainless steel plates (AISI 316), copper-brazed
- Stainless steel connections with female thread (standard)
- Permitted operating pressure: 30 bar

Part No.	Designation	Height [mm]	Width [mm]	Number of plates
3455621	HYDAC HEX S400-10-00/G3/4"	190	76	10
3383847	HYDAC HEX S400-14-00/G3/4"	190	76	14
3455623	HYDAC HEX S400-20-00/G3/4"	190	76	20
3399435	HYDAC HEX S400-30-00/G3/4"	190	76	30
3455655	HYDAC HEX S400-40-00/G3/4"	190	76	40
3366746	HYDAC HEX S610-10-00/G1"	302	102	10
3361012	HYDAC HEX S610-20-00/G1"	302	102	20
3366754	HYDAC HEX S610-30-00/G1"	302	102	30
3366759	HYDAC HEX S610-40-00/G1"	302	102	40
3366760	HYDAC HEX S610-50-00/G1"	302	102	50
3366761	HYDAC HEX S610-60-00/G1"	302	102	60
3366762	HYDAC HEX S610-70-00/G1"	302	102	70
3527300	HYDAC HEX S610-80-00/G1"	302	102	80
3366763	HYDAC HEX S610-100-00/G1"	302	102	100
3366764	HYDAC HEX S610-120-00/G1"	302	102	120
3366787	HYDAC HEX S615-10-00/G1"	518	102	10
3366788	HYDAC HEX S615-20-00/G1"	518	102	20
3366790	HYDAC HEX S615-30-00/G1"	518	102	30
3366792	HYDAC HEX S615-40-00/G1"	518	102	40
3366793	HYDAC HEX S615-50-00/G1"	518	102	50
3366794	HYDAC HEX S615-60-00/G1"	518	102	60
3366815	HYDAC HEX S615-80-00/G1"	518	102	80
3383853	HYDAC HEX S615-100-00/G1"	518	102	100
3383854	HYDAC HEX S522-20-00/G1 1/2"	523	241	20
3383906	HYDAC HEX S522-30-00/G1 1/2"	523	241	30
3383908	HYDAC HEX S522-40-00/G1 1/2"	523	241	40
3383909	HYDAC HEX S522-50-00/G1 1/2"	523	241	50
3383910	HYDAC HEX S522-60-00/G1 1/2"	523	241	60
3383911	HYDAC HEX S522-70-00/G1 1/2"	523	241	70
3383913	HYDAC HEX S522-80-00/G1 1/2"	523	241	80
3383914	HYDAC HEX S522-100-00/G1 1/2"	523	241	100
3383925	HYDAC HEX S522-120-00/G1 1/2"	523	241	120
3457465	HYDAC HEX S722-20-00/G1 1/2"	609	182	20
3457473	HYDAC HEX S722-30-00/G1 1/2"	609	182	30
3457474	HYDAC HEX S722-40-00/G1 1/2"	609	182	40
3457486	HYDAC HEX S722-50-00/G1 1/2"	609	182	50
3457489	HYDAC HEX S722-60-00/G1 1/2"	609	182	60
3457491	HYDAC HEX S722-80-00/G1 1/2"	609	182	80
3457494	HYDAC HEX S722-100-00/G1 1/2"	609	182	100
3457495	HYDAC HEX S722-120-00/G1 1/2"	609	182	120
3457496	HYDAC HEX S722-150-00/G1 1/2"	609	182	150

For further information, see brochure no. 5.815 (Plate Heat Exchangers).



Clamping Bands for Brazen Plate Heat Exchangers

Part No.	Designation	Exchanger type
3092917	HRGBLPU 25 HEX-400 ST	HYDAC HEX S400
3014028	HRGBLPU 25 HEX-610 ST	HYDAC HEX S610
3014029	HRGBLPU 25 HEX-615 ST	HYDAC HEX S615
3343306	HRGBLPU 25 HEX-522 ST	HYDAC HEX S522
3013884	HRGBLPU 25 HEX-722 ST	HYDAC HEX S722

For further information, see brochure no. 5.815 (Plate Heat Exchangers).

For **60 plates and above** it is recommended that two clamping bands are used for installation.



MFZP

- Vane pump with flanged motor
- In direct drive version
- Operating pressure: max. 6 bar

VPBM

- Vane pump with bell housing, coupling and motor
- Low-noise version
- Operating pressure: max. 16 bar

Part No.	Designation	Seal	Motor rating	Flow rate
723803	MFZP-1/1.1/P/AMG/10/RV4.5/0.2/24V-IP65	Perbunan	0.20 kW (DC)	10.0 cm ³ /rev
721042	MFZP-1/1.1/P/71/10/RV6/0.37/400-50	Perbunan	0.37 kW	10.0 cm ³ /rev
3538452	MFZP-1/1.1/V/71/ 3.5/RV8/0.25/230-50-1	Viton	0.37 kW	3.5 cm ³ /rev
721125	MFZP-2/2.1/P/80/40/RV6/0.75/400-50	Perbunan	0.75 kW	40.0 cm ³ /rev
3130117	MFZP-2/4.0/V/90/40/RV7/1.5/400-50	Viton	1.50 kW	40.0 cm ³ /rev
721177	MFZP-3/3.0/P/112/130/RV6/4/400-50	Perbunan	4.00 kW	130.0 cm ³ /rev
723154	VPBM-3/1.0/P/112/100/4/400-50	Perbunan	4.00 kW	100.0 cm ³ /rev

For further information, see brochure no. 5.701 (Pumps FZP/MFZP) and brochure no. 5.702 (Pumps VP/VPB/VPBM).

Note

The information in this brochure relates to the operating conditions and applications described.

For applications and/or operating conditions not described, please contact the relevant technical department.

Subject to technical modifications and corrections.



HYDAC COOLING GMBH

INTERNATIONAL

Industriegebiet
66280 Sulzbach/Saar
Germany

Tel.: +49 6897 509-01
Fax: +49 6897 509-454

E-mail: cooling@hydac.com
Internet: www.hydac.com

A	AUSTRIA (Slovenia, Croatia, Bosnia-Herzegovina, Serbia and Montenegro, Macedonia) HYDAC Hydraulik Ges.m.b.H. Industriesr. 3 4066 Pasching Tel.: +43 7223 6 18 11-0 Fax: +43 7223 6 18 11-35 E-mail: vt_a@hydac.com	DK	HYDAC-Büro Süd Dieselstr. 30 71546 Aspach Tel.: +49 (0)7191 / 34 51-0 Fax: +49 (0)7191 / 34 51-4033 HYDAC-Büro München Am Anger 8 82237 Würthsee/ Eterschlag Tel.: +49 (0)8153 / 987 48-0 Fax: +49 (0)8153 / 987 48-4822	MEX	MEXICO HYDAC International SA de CV Calle Alfredo A. Nobel No. 35 Colonia Puente de Vigas Tlalnepantla Edo. De México, CP 54090 Tel.: +52 55 4777 1272 al 65 Fax: +52 55 5390 2334 Internet: www.hydacmex.com	ROM	KOREA HYDAC Korea Co. Ltd. 6 th floor Daewon Bldg. 175 Bangbae Jungang-ro, Seocho-gu Seoul 137-829 Tel.: +82 2 / 591 09 31 Fax: +82 2 / 591 09 32 E-mail: johnkim@hydockorea.co.kr
AUS	AUSTRALIA HYDAC PTY. LTD. 109 Dohertys Road. Altona North, VIC 3025 Postal address: P.O. Box 224 Altona North, VIC 3025 Tel.: +61 3 / 92 72 89 00 Fax: +61 3 / 98 360 80 70 E-mail: info@hydac.com.au Internet: hydac.com.au	EE	DENMARK HYDAC A/S Havretøften 5 5550 Langeskov Tel.: +45 70 27 02 99 Fax: +45 63 13 25 40 E-mail: hydac@hydac.dk	NL	NORWAY HYDAC AS Bergthagan 4 1405 Langhus Tel.: +47 84 85 86 00 Fax: +47 84 85 86 01 E-mail: firmapost@hydac.no	ROK	ROMANIA HYDAC SRL 12 Soseaua Vestului Street, Et 2 100298, Ploiesti, Prahova county Prahova county Tel.: +40 244 575 778 Fax: +40 244 575 779 E-mail: hydac@hydac.ro Internet: www.hydac.ro
B	BELGIUM HYDAC A.S./N.V. Overhaemlaan 33 3700 Tongeren Tel.: +32 12 / 26 04 00 Fax: +32 12 / 26 04 09	ET	SPAIN HYDAC Technology SL C/ Solsones 54 - Pol. Ind. Pla de la Bruguera 08211 Castellar del Valles Tel.: +34 93 / 747 36 09 Fax: +34 93 / 715 95 42 E-mail: a.masoliver@hydac.es	NZ	NETHERLANDS HYDAC B.V. Vossenbeemd 109 5705 CL Helmond Tel.: +31 492 / 59 74 70 Fax: +31 492 / 59 74 80 E-mail: info@hydac.nl	S	SWEDEN HYDAC Fluidteknik AB Domnarvsgatan 29 16353 Spånga Tel.: +46 8 / 445 29 70 Fax: +46 8 / 445 29 90 E-mail: hydac@hydac.se Internet: www.hydac.se
BG	BULGARIA HYDAC EOOD Business Center Iskar-Yug Munchen Str. 14 1528 Sofia Tel.: +359 2 / 9706070 Fax: +359 2 / 9706075 E-mail: office@hydac.bg Internet: www.hydac.bg	F	EGYPT Yasser Fahmy Hydraulic Eng. 65-66-68 Saudi Building, Kobba P.O. Box 6550 Sawah 11813 Cairo Tel.: +202 (2) / 4520192, 4530922 Fax: +202 (2) / 4530638 E-mail: yasserf@yf-hydraulic.com.eg	P	NEW ZEALAND HYDAC LTD. 108A Penrose Road Mount Wellington 1060 Auckland Tel.: +64 9271 4120 Fax: +64 9271 4124 E-mail: info@hydac.co.nz Internet: www.hydac.co.nz	SGP	SINGAPORE HYDAC Technology Pte Ltd. 2A Second Chin Bee Road Singapore 618781 Tel.: +65 67 41 74 58 Fax: +65 67 41 04 34 E-mail: thomas.lek@hydac.com.sg Internet: www.hydac.com.sg
BLR	BELARUS HYDAC Belarus ul. Timirjazeva 65a, Biura 504-505 220035 Minsk Tel.: +375 17 209 01 32 Fax: +375 17 209 01 35 E-Mail: info@hydac.com.by Internet: www.hydac.com.by	FR	FRANCE HYDAC S.a.r.l. Technopôle Forbach Sud B.P. 30260 57604 Forbach Cedex Tel.: +33 3 / 87 29 26 00 Fax: +33 3 / 87 85 90 81 E-mail: hydac_france@hydac.com Agence de Paris Tel.: +33 1 / 60 13 97 26 Agence de Lyon Tel.: +33 4 / 78 87 83 02 Agence de Bordeaux Tel.: +33 5 / 57 54 25 25 Agence de Martignes Tel.: +33 4 / 42 49 61 35 Agence Centre-Est Tel.: +33 3 / 81 63 01 65	PL	PORTUGAL CUDELL - Engenharia & Serviços, Lda. Rua Eng.º Ferreira Dias, 954 4149-008 Porto Tel.: +351 226 158 029 Fax: +351 226 158 011 E-mail: info-+e+s@cudellengenharia.pt Internet: www.cudellengenharia.pt MOVICONTROL S.A. Rua Prof. Henrique Barros, 5B 2685-339 Prior Velho 1801 Lisboa Codex Tel.: +351 21 94 2 9900 Fax: +351 21 94 1 3500 E-mail: geral@movicontrol.pt Internet: www.movicontrol.pt	SK	SLOVAKIA HYDAC S.R.O. Gorkého 4 036 01 Martin Tel.: +421 43 / 413 58 93, 423 73 94, 422 08 75 Fax: +421 43 / 422 08 74 E-mail: hydac@hydac.sk Internet: www.hydac.sk
BR	BRAZIL HYDAC Tecnologia Ltda. Estrada Futuro Yida, 225 Bairro Cooperativa, 09852-060 Sao Bernardo do Campo Sao Paulo Tel.: +55 11 / 43 93 66 00 Fax: +55 11 / 43 93 66 17 E-mail: hydac@hydac.com.br Internet: www.hydac.com.br	GB	FINLAND HYDAC OY Kisällintie 5 01730 Vantaa Tel.: +358 10 773 7100 Fax: +358 10 773 7120 E-mail: hydac@hydac.fi Internet: www.hydac.fi	PRC	POLAND (Latvia, Lithuania) HYDAC SPZ O.O. ul. Reymonta 17 43-190 Mikolow Tel.: +48 32 / 226 26 55, 326 01 10 Fax: +48 32 / 226 40 42 E-mail: info@hydac.com.pl Internet: www.hydac.com.pl	SL	SLOVENIA HYDAC d.o.o. Zagrebska Cesta 20 2000 Maribor Tel.: +386 2 / 460 15 20 Fax: +386 2 / 460 15 22 E-mail: info@hydac.si Internet: www.hydac.si
CDN	CANADA HYDAC Corporation 14 Federal Road Welland, Ontario L3B 3P2 Tel.: +1 905 / 714 93 22 Fax: +1 905 / 714 46 64 E-mail: sales@hydac.ca Internet: www.hydac.ca	GR	GREAT BRITAIN HYDAC Technology Limited De Havilland Way, Windrush Park Witney, Oxfordshire OX29 0YG Tel.: +44 1993 86 63 66 Fax: +44 1993 86 63 65 E-mail: info@hydac.co.uk Internet: www.hydac.co.uk	RUS	RUSSIA HYDAC International ul. 4, Magistralnaja 5, office 31 123007 Moscow Tel.: +7 495 / 980 80 01 Fax: +7 495 / 980 70 20 E-mail: info@hydac.com.ru Internet: www.hydac.com.ru Technical Office St. Petersburg Nab. Obvodnogo kanala 138 190020 St. Petersburg Tel.: +7 812 / 495 9462 Fax: +7 812 / 495 9463 E-mail: petersb@hydac.com.ru Technical Office Novokuznetsk ul. Niewskogo 1, office 300 654079 Novokuznetsk Tel.: +7 3843 99 1346 Fax: +7 3843 99 1345 E-mail: novokuz@hydac.com.ru Technical Office Ulyanovsk ul. Efremova 29, office 418 432042 Ulyanovsk Tel.: +7 8422 61 3453 Fax: +7 8422 61 3452 E-mail: uljan@hydac.com.ru	TR	TURKEY HYDAC AKIŞKAN KONTROL SİSTEMLERİ SAN. VE TİC. LTD. ŞTİ. Namik Kemal Mahallesi Adile Naşit Bulvanı, 174 Sok. No. 9 34513 Esenyurt - Istanbul Tel.: +90 212 / 428 25 25 Fax: +90 212 / 428 70 37 E-mail: info@hydac.com.tr Internet: www.hydac.com.tr
CH	SWITZERLAND HYDAC Engineering AG Allmendstr. 11 6312 Steinhausen/Zug Tel.: +41 41 / 747 03 21 Fax: +41 41 / 747 03 29 E-mail: hydac-engineering-AG@hydac.com Internet: www.hydac.ch HYDAC S.A. Zona Industriale 3, Via Scersera 6805 Mezzovico Tel.: +41 91 / 935 57 00 Fax: +41 91 / 935 57 01 E-mail: info.coolingsystems@hydac.ch Internet: www.hydac.ch	HK	HONG KONG HYDAC Technology (Hongkong) Ltd. Room 602, 6/F, Silvercord Tower 1 30 Canton Road, Tsim Sha Tsui Kowloon, Hong Kong Tel.: +852 23 69 35 68 Fax: +852 23 69 35 67	RA	ARGENTINA HYDAC Technology Argentina S.R.L. Av. Belgrano 2729 (B1611DVG) Don Torcuato Tigre / Buenos Aires Tel.: +54 11 4727-1155/-0770/-2323 E-mail: argentina@hydac.com	USA	TAIWAN HYDAC Technology Ltd. No. 18, Shude 1 st Lane, South District Taichung City 40242 Tel.: +886 4 / 2260 2278 Fax: +886 4 / 2260 2352 E-mail: kc.chen@hydac.com.tw Internet: www.hydac.com.tw
CZ	CZECH REPUBLIC HYDAC spol. S.R.O. Kanáďská 794 391 11 Planá nad Luznicí Tel.: +420 381 / 20 17 11 Fax: +420 381 / 29 12 70 E-mail: hydac@hydac.cz Internet: www.hydac.cz	H	HUNGARY HYDAC Hidraulika és Szűréstechnika Kft. Ezred u. 16 1044 Budapest Tel.: +36 1 359 93 59 Fax: +36 1 239 73 02 E-mail: hydac@hydac.hu Internet: www.hydac.hu	UA	UKRAINE HYDAC Technology Corporation HYDAC Corp. 2260 & 2280 City Line Road Bethlehem, PA 18017 Tel.: +1 610 / 266 01 00 Fax: +1 610 / 266 35 40 E-mail: sales@hydacusa.com Internet: www.hydacusa.com		
D	GERMANY HYDAC-Büro Berlin IBH Ingenieurbüro und Handelsvertretung Hammer GmbH Kaiser-Wilhelm-Str. 17 12247 Berlin Tel.: +49 (0)30 / 772 80 50 Fax: +49 (0)30 / 773 80 80 HYDAC-Büro Südost Wiesestr. 189 07551 Gera Tel.: +49 (0)365 / 73 97 5320 Fax: +49 (0)365 / 73 97 5310 HYDAC-Büro Nordost Zum Kiesberg 16 14979 Großbeeren Tel.: +49 (0)33701 / 3389-0 Fax: +49 (0)33701 / 3389-4499 HYDAC-Büro Bremen Riedemannstr. 1 27572 Bremerhaven Tel.: +49 (0)471 / 700572-4200 Fax: +49 (0)471 / 700572-4242 HYDAC-Büro Hamburg Mühlenweg 131-139 22844 Norderstedt Tel.: +49 (0)40 / 52 60 07-0 Fax: +49 (0)40 / 52 60 07-15 HYDAC-Büro Nord Kirchhorster Str. 39 30659 Hannover Tel.: +49 (0)511 / 56 35 35-0 Fax: +49 (0)511 / 56 35 35-56 HYDAC-Büro West Münchener Str. 61 45145 Essen Tel.: +49 (0)201 / 320 89 51-00 Fax: +49 (0)201 / 320 89 52-22 HYDAC-Büro Mitte Dieselstr. 9 64293 Darmstadt Tel.: +49 (0)6151 / 81 45-0 Fax: +49 (0)6151 / 81 45-22 HYDAC-Büro Südwest Rehgrabenstr. 3 66125 Saarbrücken-Dudweiler Tel.: +49 (0)6897 / 509-01 Fax: +49 (0)6897 / 509-1422	I	ITALY HYDAC S.p.A. Via Archimede 76 20864 Agrate Brianza (MB) Tel.: +39 039 / 64 22 11 Fax: +39 039 / 68 99 682 E-mail: hydac@hydac.it Internet: www.hydac.it	ZA	VIETNAM HYDAC International E-Town Building, Mezzanine Floor Executive office, Room 7 364 Cong Hoa Street, Tan Binh District Ho Chi Minh City Tel.: +84 88 120 345 Ext. 215 Fax: +84 88 120 546		
IND	INDIA HYDAC INDIA PVT. LTD. A-58 TTC Industrial Area, MIDC, Mahape Navi Mumbai 400 701 Tel.: +91 22 / 411 18-888 Fax: +91 22 / 2778 11 80 E-mail: k.venkat@hydacindia.com	J	JAPAN HYDAC CO. LTD. KSK Bldg, Main-2F 3-25-7 Hatchobori, Chuo-ku Tokyo 104-0032 Tel.: +81 3 / 35 37-3620 Fax: +81 3 / 35 37-3622	RA	ARGENTINA HYDAC Tecnología Chile Ltda. Las Araucarias 9080-9110 / módulo F Parque Industrial Las Araucarias 8720041 Quilicura / Santiago Tel.: +56 2 / 5 84 67 54 Fax: +56 2 / 5 84 67 55 E-mail: guillermo.viertel@hydac.com		
L	LUXEMBURG Friederich-Hydropart S.à.r.l. Route d'Esch, C.P. 38 3801 Schifflange Tel.: +352 54 52 44 Fax: +352 54 52 48	K	KOREA HYDAC International SA de CV Calle Alfredo A. Nobel No. 35 Colonia Puente de Vigas Tlalnepantla Edo. De México, CP 54090 Tel.: +52 55 4777 1272 al 65 Fax: +52 55 5390 2334 Internet: www.hydacmex.com	RA	ARGENTINA HYDAC Tecnología Argentina S.R.L. Av. Belgrano 2729 (B1611DVG) Don Torcuato Tigre / Buenos Aires Tel.: +54 11 4727-1155/-0770/-2323 E-mail: argentina@hydac.com		
MAL	MALAYSIA HYDAC Technology Sdn. Bhd. 16, Jalan Pengacara U1 / 48 Temasya Industrial Park 40150 Shah Alam Selangor Darul Ehsan Tel.: +60 3 / 5567 0250, 0251, 0253 Fax: +60 3 / 5567 0252 E-mail: query@hydac.com.my	L	LUXEMBURG Friederich-Hydropart S.à.r.l. Route d'Esch, C.P. 38 3801 Schifflange Tel.: +352 54 52 44 Fax: +352 54 52 48	RA	ARGENTINA HYDAC Tecnología Argentina S.R.L. Av. Belgrano 2729 (B1611DVG) Don Torcuato Tigre / Buenos Aires Tel.: +54 11 4727-1155/-0770/-2323 E-mail: argentina@hydac.com		

HYDAC INTERNATIONAL



Accumulator Technology 30,000



Filter Technology 70,000



Process Technology 77,000



Filter Systems 79,000



Compact Hydraulics 53,000



Accessories 61,000



Electronics 180,000



Cooling Systems 57,000

Global Presence. Local Expertise. www.hydac.com



- HYDAC Headquarters
- HYDAC Companies
- HYDAC Sales and Service Partners

HYDAC INTERNATIONAL

**HYDAC COOLING
GMBH**

Industriegebiet
66280 Sulzbach/Saar
Germany

Tel.: +49 6897 509-01
Fax: +49 6897 509-454

E-mail: cooling@hydac.com
Internet: www.hydac.com